



N Male to N Male Low Loss Cable Using LMR-600 Coax with HeatShrink, LF Solder

TECHNICAL DATA SHEET

PE3C0062LF/HS

Configuration

- Connector 1: N Male
- Connector 2: N Male
- Cable Type: LMR-600
- Coax Flex Type: Flexible

Features

- Max Frequency 6 GHz
- Shielding Effectivity > 90 dB
- 87% Phase Velocity
- Double Shielded
- PE Jacket

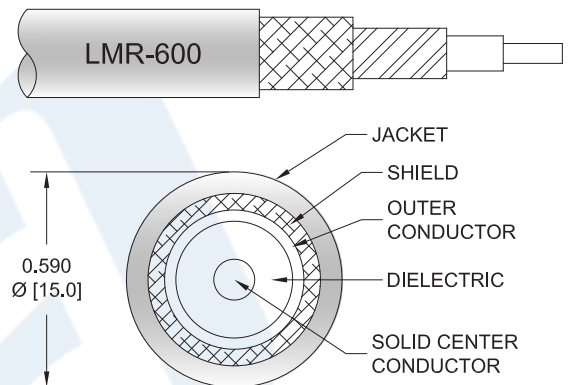

Applications

- General Purpose
- Laboratory Use

Description

Pasternack's PE3C0062LF/HS type N male to type N male cable using LMR-600 coax is part of our full line of RF components available for same-day shipping. Pasternack's flexible RF cable assemblies are ideal for applications where tight bends and flexure are required. This Pasternack type N to type N cable assembly has a male to male gender configuration with 50 ohm flexible LMR-600 coax. The PE3C0062LF/HS type N male to type N male cable assembly operates to 6 GHz. The double shielding of this Pasternack cable assembly provides excellent shielding effectiveness of better than 90 dB.

Custom versions of most RF cable assemblies can be built and shipped same day. Custom cable assembly lengths can be obtained by specifying the desired length on the web site at time of order or by contacting a sales representative. Other available RF cable assembly value added services include connector orientation or clocking, heat shrink booting and custom labeling. RF testing can also be performed to document the electrical performance of your cable assembly.

Click the following link (or enter part number in "SEARCH" on website) to obtain additional part information including price, inventory and certifications: [N Male to N Male Low Loss Cable Using LMR-600 Coax with HeatShrink, LF Solder PE3C0062LF/HS](#)



N Male to N Male Low Loss Cable Using LMR-600 Coax with HeatShrink, LF Solder

TECHNICAL DATA SHEET

PE3C0062LF/HS

Electrical Specifications

Description	Minimum	Typical	Maximum	Units
Frequency Range	DC		6	GHz
VSWR			1.4:1	
Velocity of Propagation		87		%
RF Shielding	90			dB
Group Delay		1.17 [3.84]		ns/ft [ns/m]
Capacitance		23.4 [76.77]		pF/ft [pF/m]
Inductance		0.058 [0.19]		uH/ft [uH/m]
DC Resistance Inner Conductor		0.53 [1.74]		Ω /1000ft [Ω /Km]
DC Resistance Outer Conductor		1.2 [3.94]		Ω /1000ft [Ω /Km]
Jacket Spark			8,000	Vrms

Specifications by Frequency

Part Number	Length	Description	F1	F2	F3	F4	F5	Units	Weight (lbs)
			Frequency						
PE3C0062LF/HS	Custom Lengths Available	Insertion Loss (Typ.)	0.01	0.02	0.03	0.04	0.07	dB/ft	
			0.04	0.06	0.09	0.15	0.24	dB/m	
PE3C0062LF/HS-24	24 inch	Insertion Loss (Typ.)	0.23	0.24	0.26	0.29	0.35	dB	0.573
PE3C0062LF/HS-36	36 inch	Insertion Loss (Typ.)	0.24	0.26	0.28	0.34	0.42	dB	0.71
PE3C0062LF/HS-48	48 inch	Insertion Loss (Typ.)	0.25	0.27	0.31	0.38	0.5	dB	0.847
PE3C0062LF/HS-120	120 inch	Insertion Loss (Typ.)	0.32	0.37	0.46	0.64	0.93	dB	1.669
PE3C0062LF/HS-180	180 inch	Insertion Loss (Typ.)	0.38	0.46	0.59	0.86	1.3	dB	2.354

The insertion loss data for the base model does not include loss due to the connectors. Each length includes insertion loss due to the connectors.

Loss due to Connector 1:	0.1 dB
Loss due to Connector 2:	0.1 dB
Base Weight:	0.435 pounds
Additional Weight per Inch:	0.01142 pounds

Mechanical Specifications

Cable Assembly

Weight 0.435 lbs [197.31 g]

Click the following link (or enter part number in "SEARCH" on website) to obtain additional part information including price, inventory and certifications: [N Male to N Male Low Loss Cable Using LMR-600 Coax with HeatShrink, LF Solder PE3C0062LF/HS](#)



N Male to N Male Low Loss Cable Using LMR-600 Coax with HeatShrink, LF Solder

TECHNICAL DATA SHEET

PE3C0062LF/HS

Cable

Cable Type	LMR-600
Impedance	50 Ohms
Inner Conductor Type	Solid
Inner Conductor Material and Plating	Copper Clad Aluminum
Dielectric Type	PE (F)
Number of Shields	2
Shield Layer 1	Aluminum Tape
Shield Layer 2	Tinned Copper Braid
Jacket Material	PE, Black
Jacket Diameter	0.59 in [14.99 mm]
One Time Minimum Bend Radius	1.5 in [38.1 mm]
Repeated Minimum Bend Radius	6 in [152.4 mm]
Bending Moment	2.75 lbs-ft [3.73 N-m]
Flat Plate Crush	60 lbs/in [1.07 Kg/mm]
Tensile Strength	350 lbs [158.76 Kg]

Connectors

Description	Connector 1	Connector 2
Type	N Male Threaded	N Male Threaded
Impedance	50 Ohms	50 Ohms
Contact Material and Plating	Brass, Gold	Brass, Gold
Dielectric Type	PTFE	PTFE
Body Material and Plating	Brass, Tri-Metal	Brass, Tri-Metal
Coupling Nut Material and Plating	Brass, Tri-Metal	Brass, Tri-Metal

Environmental Specifications

Temperature

Operating Range -40 to +85 deg C

Compliance Certifications (see [product page](#) for current document)

Plotted and Other Data

Notes:

Click the following link (or enter part number in "SEARCH" on website) to obtain additional part information including price, inventory and certifications: [N Male to N Male Low Loss Cable Using LMR-600 Coax with HeatShrink, LF Solder PE3C0062LF/HS](#)



N Male to N Male Low Loss Cable Using LMR-600 Coax with HeatShrink, LF Solder

TECHNICAL DATA SHEET

PE3C0062LF/HS

How to Order

Part Number Configuration:

PE3C0062LF/HS - xx

uu

Unit of Measure:
cm = Centimeters
<blank> = Inches
Length
Base Number

Example: PE3C0062LF/HS-12 = 12 inches long cable
PE3C0062LF/HS-100cm = 100 cm long cable

N Male to N Male Low Loss Cable Using LMR-600 Coax with HeatShrink, LF Solder from Pasternack Enterprises has same day shipment for domestic and International orders. Our RF, microwave and millimeter wave products maintain a 99.4% availability and are part of the broadest selection in the industry.

Click the following link (or enter part number in "SEARCH" on website) to obtain additional part information including price, inventory and certifications: [N Male to N Male Low Loss Cable Using LMR-600 Coax with HeatShrink, LF Solder PE3C0062LF/HS](#)

URL: <https://www.pasternack.com/n-male-to-n-male-low-loss-cable-using-lmr-600-with-heatshrink-lf-solder-pe3c0062lf-hs-p.aspx>

The information contained in this document is accurate to the best of our knowledge and representative of the part described herein. It may be necessary to make modifications to the part and/or the documentation of the part, in order to implement improvements. Pasternack reserves the right to make such changes as required. Unless otherwise stated, all specifications are nominal. Pasternack does not make any representation or warranty regarding the suitability of the part described herein for any particular purpose, and Pasternack does not assume any liability arising out of the use of any part or documentation.

PE3C0062LF/HS CAD Drawing

N Male to N Male Low Loss Cable Using LMR-600 Coax with HeatShrink, LF Solder

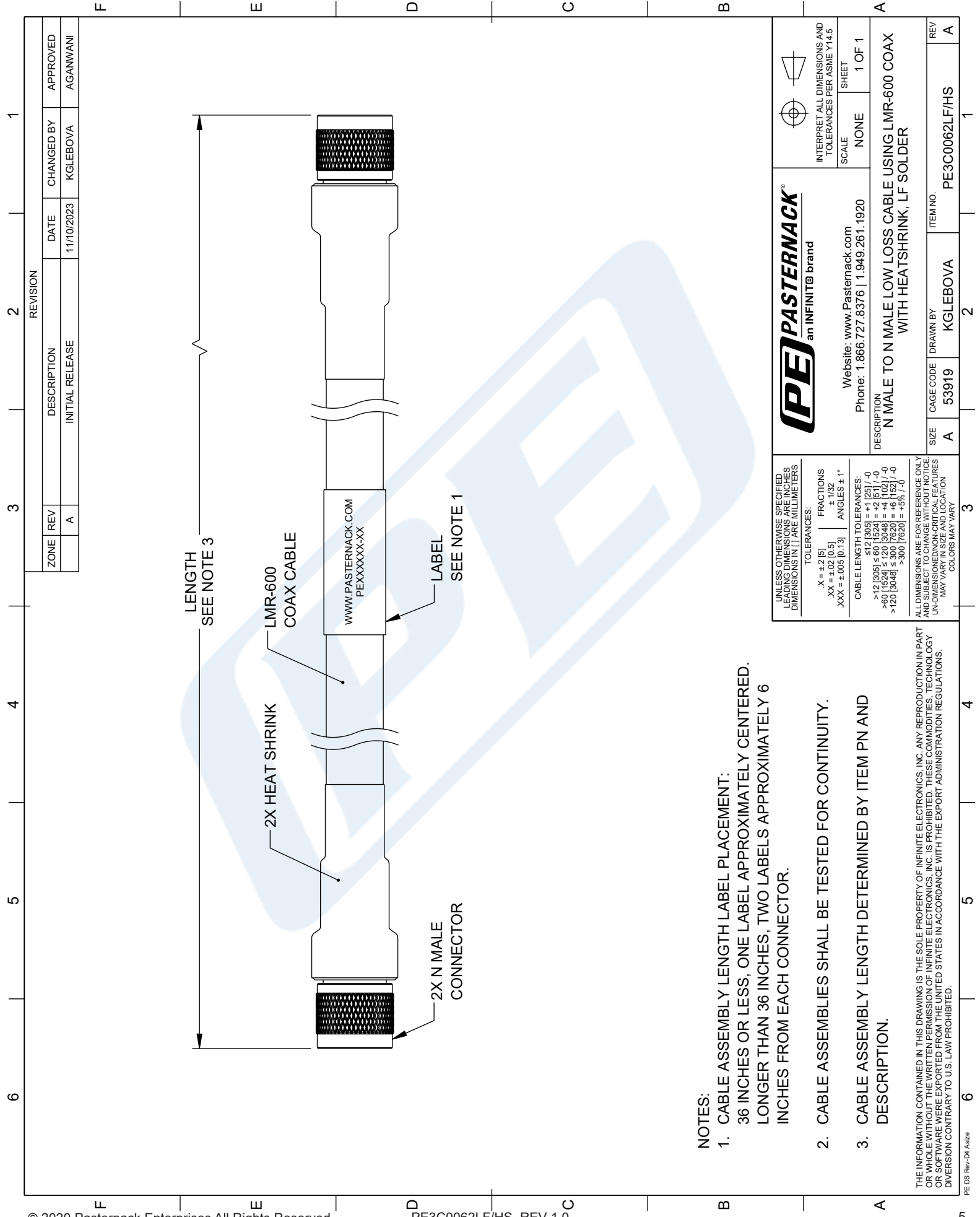

ZONE		REV	DESCRIPTION	DATE	CHANGED BY	APPROVED
		A	INITIAL RELEASE	11/10/2023	KGLEBOVA	AGANWANI

LENGTH
SEE NOTE 3

2X HEAT SHRINK

LMR-600
COAX CABLE

WWW.PASTERNAK.COM
PEXXXXX-XX

LABEL
SEE NOTE 1

2X N MALE
CONNECTOR

NOTES:

- CABLE ASSEMBLY LENGTH LABEL PLACEMENT:
36 INCHES OR LESS, ONE LABEL APPROXIMATELY CENTERED.
LONGER THAN 36 INCHES, TWO LABELS APPROXIMATELY 6 INCHES FROM EACH CONNECTOR.
- CABLE ASSEMBLIES SHALL BE TESTED FOR CONTINUITY.
- CABLE ASSEMBLY LENGTH DETERMINED BY ITEM PN AND DESCRIPTION.

THE INFORMATION CONTAINED IN THIS DRAWING IS THE SOLE PROPERTY OF INFINITE ELECTRONICS, INC. ANY REPRODUCTION IN PART OR WHOLE WITHOUT THE WRITTEN PERMISSION OF INFINITE ELECTRONICS, INC. IS PROHIBITED. THESE COMMODITIES, TECHNOLOGY OR SOFTWARE WERE EXPORTED FROM THE UNITED STATES IN ACCORDANCE WITH THE EXPORT ADMINISTRATION REGULATIONS. DIVERSION CONTRARY TO U.S. LAW PROHIBITED.

UNLESS OTHERWISE SPECIFIED LENGTHS AND DIMENSIONS ARE IN INCHES DIMENSIONS IN [] ARE MILLIMETERS		 INTERPRET ALL DIMENSIONS AND TOLERANCES PER ASME Y14.5	
TOLERANCES:	FRACTIONS	SCALE	SHEET
X = ±.2 [5]	±.1/32	NONE	1 OF 1
XX = ±.02 [0.5]	±.005 [0.13]		
XXX = ±.005 [0.13]	ANGLES ± 1°		
CABLE LENGTH TOLERANCES:		Website: www.Pasternack.com	
>12 [305] ≤ 60 [1524] = ±.25 / -0		Phone: 1.866.727.8376 1.949.261.1920	
60 [1524] ≤ 120 [3048] = ±.4 [102] / -0		DESCRIPTION	
>120 [3048] ≤ 300 [7620] = ±.6 [152] / -0		N MALE TO N MALE LOW LOSS CABLE USING LMR-600 COAX	
>300 [7620] = ±.9% / -0		WITH HEATSHRINK, LF SOLDER	
ALL DIMENSIONS ARE FOR REFERENCE ONLY UNLESS OTHERWISE SPECIFIED UNDIMENSIONED CRITICAL FEATURES MAY VARY IN SIZE AND LOCATION COLORS MAY VARY			

PASTERNAK an INFINIT@ brand		SCALE NONE	
Website: www.Pasternack.com Phone: 1.866.727.8376 1.949.261.1920		SHEET 1 OF 1	
DESCRIPTION			
N MALE TO N MALE LOW LOSS CABLE USING LMR-600 COAX WITH HEATSHRINK, LF SOLDER			
SIZE	CAGE CODE	DRAWN BY	ITEM NO.
A	53919	KGLEBOVA	PE3C0062LF/HS
REV			A