



N Male to N Female Low Loss Cable Using LMR-240 Coax, LF Solder

TECHNICAL DATA SHEET

PE3C0233LF

Configuration

- Connector 1: N Male
- Connector 2: N Female
- Cable Type: LMR-240
- Coax Flex Type: Flexible

Features

- Max Frequency 6 GHz
- Shielding Effectivity > 90 dB
- 84% Phase Velocity
- Double Shielded
- PE Jacket

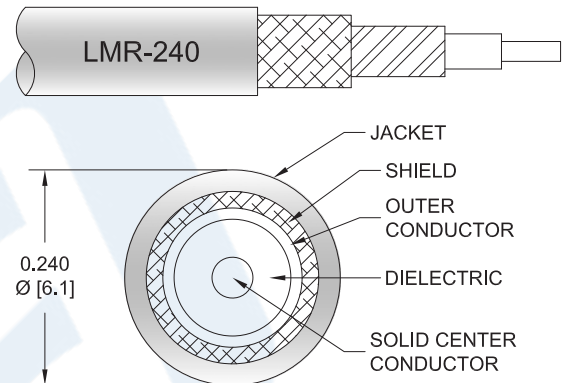

Applications

- General Purpose
- Laboratory Use

Description

Pasternack's PE3C0233LF type N male to type N female cable using LMR-240 coax is part of our full line of RF components available for same-day shipping. Pasternack's flexible RF cable assemblies are ideal for applications where tight bends and flexure are required. This Pasternack type N to type N cable assembly has a male to female gender configuration with 50 ohm flexible LMR-240 coax. The PE3C0233LF type N male to type N female cable assembly operates to 6 GHz. The double shielding of this Pasternack cable assembly provides excellent shielding effectiveness of better than 90 dB.

Custom versions of most RF cable assemblies can be built and shipped same day. Custom cable assembly lengths can be obtained by specifying the desired length on the web site at time of order or by contacting a sales representative. Other available RF cable assembly value added services include connector orientation or clocking, heat shrink booting and custom labeling. RF testing can also be performed to document the electrical performance of your cable assembly.

Click the following link (or enter part number in "SEARCH" on website) to obtain additional part information including price, inventory and certifications: [N Male to N Female Low Loss Cable Using LMR-240 Coax, LF Solder PE3C0233LF](#)



N Male to N Female Low Loss Cable Using LMR-240 Coax, LF Solder

TECHNICAL DATA SHEET

PE3C0233LF

Electrical Specifications

Description	Minimum	Typical	Maximum	Units
Frequency Range	DC		6	GHz
VSWR			1.4:1	
Velocity of Propagation		84		%
RF Shielding	90			dB
Group Delay		1.21 [3.97]		ns/ft [ns/m]
Capacitance		24.2 [79.4]		pF/ft [pF/m]
Inductance		0.06 [0.2]		uH/ft [uH/m]
DC Resistance Inner Conductor		3.2 [10.5]		Ω /1000ft [Ω /Km]
DC Resistance Outer Conductor		3.89 [12.76]		Ω /1000ft [Ω /Km]
Jacket Spark			5,000	Vrms

Specifications by Frequency

Part Number	Length	Description	F1	F2	F3	F4	F5	Units	Weight (lbs)
		Frequency	250	500	1000	2500	6000	MHz	
PE3C0233LF	Custom Lengths Available	Insertion Loss (Typ.)	0.04	0.06	0.08	0.13	0.2	dB/ft	
			0.13	0.19	0.26	0.43	0.67	dB/m	
PE3C0233LF-12	12 inch	Insertion Loss (Typ.)	0.24	0.26	0.28	0.33	0.41	dB	0.17
PE3C0233LF-24	24 inch	Insertion Loss (Typ.)	0.28	0.31	0.36	0.46	0.61	dB	0.203
PE3C0233LF-36	36 inch	Insertion Loss (Typ.)	0.32	0.37	0.44	0.59	0.82	dB	0.236
PE3C0233LF-48	48 inch	Insertion Loss (Typ.)	0.36	0.42	0.52	0.72	1.02	dB	0.269
PE3C0233LF-60	60 inch	Insertion Loss (Typ.)	0.4	0.48	0.6	0.85	1.22	dB	0.302

The insertion loss data for the base model does not include loss due to the connectors. Each length includes insertion loss due to the connectors.

Loss due to Connector 1:	0.1 dB
Loss due to Connector 2:	0.1 dB
Base Weight:	0.17 pounds
Additional Weight per Inch:	0.00275 pounds

Mechanical Specifications

Cable Assembly

Weight 0.17 lbs [77.11 g]

Click the following link (or enter part number in "SEARCH" on website) to obtain additional part information including price, inventory and certifications: [N Male to N Female Low Loss Cable Using LMR-240 Coax, LF Solder PE3C0233LF](#)



N Male to N Female Low Loss Cable Using LMR-240 Coax, LF Solder

TECHNICAL DATA SHEET

PE3C0233LF

Cable

Cable Type	LMR-240
Impedance	50 Ohms
Inner Conductor Type	Solid
Inner Conductor Material and Plating	Copper
Dielectric Type	PE (F)
Number of Shields	2
Shield Layer 1	Aluminum Tape
Shield Layer 2	Tinned Copper Braid
Jacket Material	PE, Black
Jacket Diameter	0.24 in [6.1 mm]
One Time Minimum Bend Radius	0.75 in [19.05 mm]
Repeated Minimum Bend Radius	2.5 in [63.5 mm]
Bending Moment	0.25 lbs-ft [0.34 N-m]
Flat Plate Crush	20 lbs/in [0.36 Kg/mm]
Tensile Strength	80 lbs [36.29 Kg]

Connectors

Description	Connector 1	Connector 2
Type	N Male Threaded	N Female Threaded
Specification	MIL-STD-348A	
Impedance	50 Ohms	50 Ohms
Contact Material and Plating	Brass, Gold	Beryllium Copper, Gold
Contact Plating Specification	30 µin minimum	
Dielectric Type	PTFE	PTFE
Body Material and Plating	Brass, Nickel	Brass, Tri-Metal
Body Plating Specification	100 µin minimum	
Coupling Nut Material and Plating	Brass, Nickel	
Coupling Nut Plating Specification	100 µin minimum	

Environmental Specifications

Temperature

Operating Range -40 to +85 deg C

Compliance Certifications (see [product page](#) for current document)

Plotted and Other Data

Notes:

Click the following link (or enter part number in "SEARCH" on website) to obtain additional part information including price, inventory and certifications: [N Male to N Female Low Loss Cable Using LMR-240 Coax, LF Solder PE3C0233LF](#)



N Male to N Female Low Loss Cable Using LMR-240 Coax, LF Solder

TECHNICAL DATA SHEET

PE3C0233LF

How to Order

Part Number Configuration:

PE3C0233LF - xx uu

Unit of Measure:
cm = Centimeters
<blank> = Inches
Length
Base Number

Example: PE3C0233LF-12 = 12 inches long cable
PE3C0233LF-100cm = 100 cm long cable

N Male to N Female Low Loss Cable Using LMR-240 Coax, LF Solder from Pasternack Enterprises has same day shipment for domestic and International orders. Our RF, microwave and millimeter wave products maintain a 99.4% availability and are part of the broadest selection in the industry.

Click the following link (or enter part number in "SEARCH" on website) to obtain additional part information including price, inventory and certifications: [N Male to N Female Low Loss Cable Using LMR-240 Coax, LF Solder PE3C0233LF](#)

URL: <https://www.pasternack.com/n-male-to-n-female-low-loss-cable-using-lmr-240-lf-solder-pe3c0233lf-p.aspx>

The information contained in this document is accurate to the best of our knowledge and representative of the part described herein. It may be necessary to make modifications to the part and/or the documentation of the part, in order to implement improvements. Pasternack reserves the right to make such changes as required. Unless otherwise stated, all specifications are nominal. Pasternack does not make any representation or warranty regarding the suitability of the part described herein for any particular purpose, and Pasternack does not assume any liability arising out of the use of any part or documentation.

PE3C0233LF CAD Drawing

N Male to N Female Low Loss Cable Using LMR-240 Coax, LF Solder

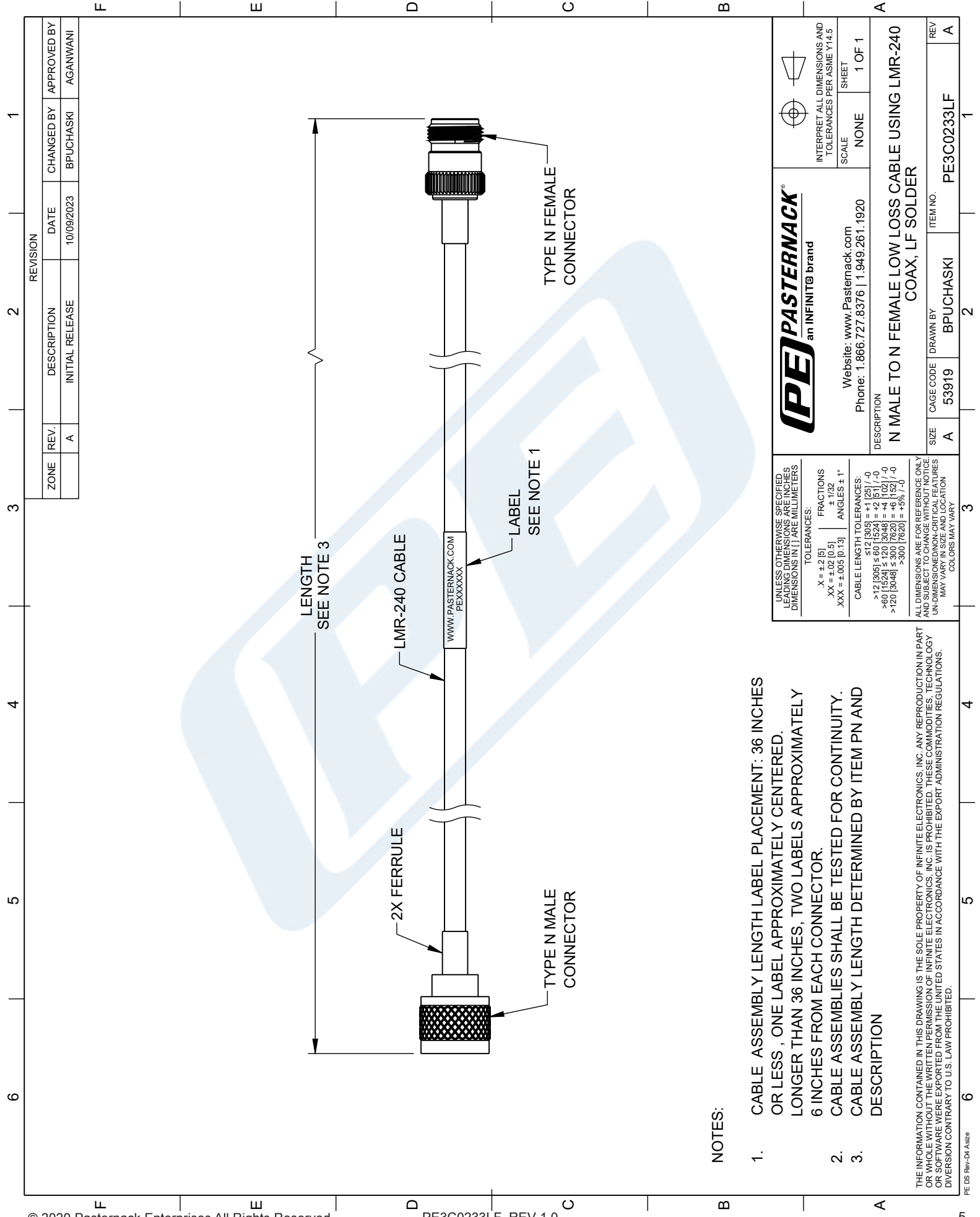

REVISION		DATE	CHANGED BY	APPROVED BY
ZONE	REV.	DESCRIPTION	INITIAL RELEASE	
	A		10/09/2023	BPUCHASKI
				AGANWANI

(PE) PASTERNAK
an INFINIT[®] brand

Website: www.Pasternack.com
Phone: 1.866.727.8376 | 1.949.261.1920

INTERPRET ALL DIMENSIONS AND TOLERANCES PER ASME Y14.5

SCALE: NONE

SHEET: 1 OF 1

DESCRIPTION:
N MALE TO N FEMALE LOW LOSS CABLE USING LMR-240 COAX, LF SOLDER

SIZE: A
CAGE CODE: 53919
DRAWN BY: BPUCHASKI
ITEM NO.: PE3C0233LF

UNLESS OTHERWISE SPECIFIED, LEADING DIMENSIONS ARE IN INCHES. DIMENSIONS IN PARENTHESES ARE IN MILLIMETERS.

TOLERANCES:
 .X = ±.2 [5]
 .XX = ±.02 [0.5]
 .XXX = ±.005 [0.13]

FRACTIONS:
 ± 1/32
 ANGLES ± 1°

CABLE LENGTH TOLERANCES:
 $\le 12 [305]$ = ±.125 / -0
 $\le 17 [432]$ = ±.150 / -0
 $\le 20 [508]$ = ±.180 / -0
 $\le 300 [7620]$ = +6 [152] / -0
 >300 [7620] = +5% / -0

ALL DIMENSIONS ARE FOR REFERENCE ONLY. UNLESS OTHERWISE SPECIFIED, DIMENSIONS MAY VARY IN SIZE AND LOCATION. COLORS MAY VARY.

- NOTES:**
- CABLE ASSEMBLY LENGTH LABEL PLACEMENT: 36 INCHES OR LESS, ONE LABEL APPROXIMATELY CENTERED. LONGER THAN 36 INCHES, TWO LABELS APPROXIMATELY 6 INCHES FROM EACH CONNECTOR.
 - CABLE ASSEMBLIES SHALL BE TESTED FOR CONTINUITY.
 - CABLE ASSEMBLY LENGTH DETERMINED BY ITEM PN AND DESCRIPTION
- THE INFORMATION CONTAINED IN THIS DRAWING IS THE SOLE PROPERTY OF INFINITE ELECTRONICS, INC. ANY REPRODUCTION IN PART OR WHOLE WITHOUT THE WRITTEN PERMISSION OF INFINITE ELECTRONICS, INC. IS PROHIBITED. THESE COMMODITIES, TECHNOLOGY OR SOFTWARE WERE EXPORTED FROM THE UNITED STATES IN ACCORDANCE WITH THE EXPORT ADMINISTRATION REGULATIONS. DIVERSION CONTRARY TO U.S. LAW PROHIBITED.