



N Male to N Male Low Loss Cable Using LMR-500 Coax, LF Solder

TECHNICAL DATA SHEET

PE3C1062LF

Configuration

- Connector 1: N Male
- Connector 2: N Male
- Cable Type: LMR-500
- Coax Flex Type: Flexible

Features

- Shielding Effectivity > 90 dB
- 86% Phase Velocity
- Double Shielded
- PE Jacket

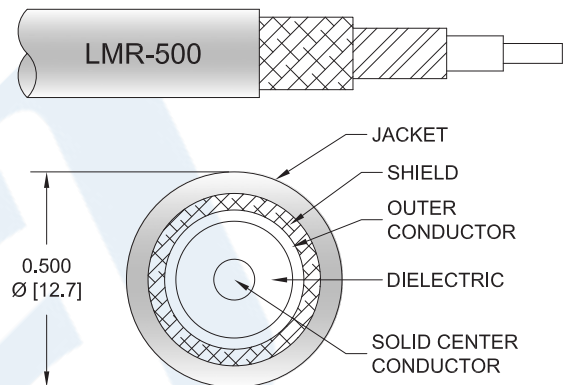

Applications

- General Purpose
- Laboratory Use

Description

Pasternack's PE3C1062LF type N male to type N male cable using LMR-500 coax is part of our full line of RF components available for same-day shipping. Pasternack's flexible RF cable assemblies are ideal for applications where tight bends and flexure are required. This Pasternack type N to type N cable assembly has a male to male gender configuration with 50 ohm flexible LMR-500 coax. The double shielding of this Pasternack cable assembly provides excellent shielding effectiveness of better than 90 dB.

Custom versions of most RF cable assemblies can be built and shipped same day. Custom cable assembly lengths can be obtained by specifying the desired length on the web site at time of order or by contacting a sales representative. Other available RF cable assembly value added services include connector orientation or clocking, heat shrink booting and custom labeling. RF testing can also be performed to document the electrical performance of your cable assembly.

Electrical Specifications

Description	Minimum	Typical	Maximum	Units
Velocity of Propagation		86		%
RF Shielding	90			dB
Capacitance		23.6 [77.43]		pF/ft [pF/m]
Inductance		0.059 [0.19]		uH/ft [uH/m]
Jacket Spark			8,000	Vrms

Click the following link (or enter part number in "SEARCH" on website) to obtain additional part information including price, inventory and certifications: [N Male to N Male Low Loss Cable Using LMR-500 Coax, LF Solder PE3C1062LF](#)



N Male to N Male Low Loss Cable Using LMR-500 Coax, LF Solder

TECHNICAL DATA SHEET

PE3C1062LF

Mechanical Specifications

Cable Assembly

Weight 0.513 lbs [232.69 g]

Cable

Cable Type LMR-500
 Impedance 50 Ohms
 Inner Conductor Type Solid
 Inner Conductor Material and Plating Copper Clad Aluminum
 Dielectric Type PE
 Number of Shields 2
 Shield Layer 1 Aluminum Tape
 Shield Layer 2 Tinned Copper
 Jacket Material PE, Black
 Jacket Diameter 0.5 in [12.7 mm]

One Time Minimum Bend Radius 1.25 in [31.75 mm]
 Repeated Minimum Bend Radius 5 in [127 mm]
 Bending Moment 1.75 lbs-ft [2.37 N-m]
 Flat Plate Crush 50 lbs/in [0.89 Kg/mm]
 Tensile Strength 260 lbs [117.93 Kg]

Connectors

Description	Connector 1	Connector 2
Type	N Male Threaded	N Male Threaded
Specification	MIL-STD-348A	MIL-STD-348A
Impedance	50 Ohms	50 Ohms
Contact Material and Plating	Brass, Gold	Brass, Gold
Contact Plating Specification	30 µin minimum	30 µin minimum
Dielectric Type	PTFE	PTFE
Body Material and Plating	Brass, Nickel	Brass, Nickel
Body Plating Specification	100 µin minimum	100 µin minimum
Coupling Nut Material and Plating	Brass, Nickel	Brass, Nickel
Coupling Nut Plating Specification	100 µin minimum	100 µin minimum

Compliance Certifications (see [product page](#) for current document)

Plotted and Other Data

Notes:

Click the following link (or enter part number in "SEARCH" on website) to obtain additional part information including price, inventory and certifications: [N Male to N Male Low Loss Cable Using LMR-500 Coax, LF Solder PE3C1062LF](#)



N Male to N Male Low Loss Cable Using LMR-500 Coax, LF Solder

TECHNICAL DATA SHEET

PE3C1062LF

How to Order

Part Number Configuration:

PE3C1062LF - xx uu

Unit of Measure:
cm = Centimeters
<blank> = Inches
Length
Base Number

Example: PE3C1062LF-12 = 12 inches long cable
PE3C1062LF-100cm = 100 cm long cable

N Male to N Male Low Loss Cable Using LMR-500 Coax, LF Solder from Pasternack Enterprises has same day shipment for domestic and International orders. Our RF, microwave and millimeter wave products maintain a 99.4% availability and are part of the broadest selection in the industry.

Click the following link (or enter part number in "SEARCH" on website) to obtain additional part information including price, inventory and certifications: [N Male to N Male Low Loss Cable Using LMR-500 Coax, LF Solder PE3C1062LF](#)

URL: <https://www.pasternack.com/n-male-to-n-male-low-loss-cable-using-lmr-500-lf-solder-pe3c1062lf-p.aspx>

The information contained in this document is accurate to the best of our knowledge and representative of the part described herein. It may be necessary to make modifications to the part and/or the documentation of the part, in order to implement improvements. Pasternack reserves the right to make such changes as required. Unless otherwise stated, all specifications are nominal. Pasternack does not make any representation or warranty regarding the suitability of the part described herein for any particular purpose, and Pasternack does not assume any liability arising out of the use of any part or documentation.

PE3C1062LF CAD Drawing

N Male to N Male Low Loss Cable Using LMR-500 Coax, LF Solder

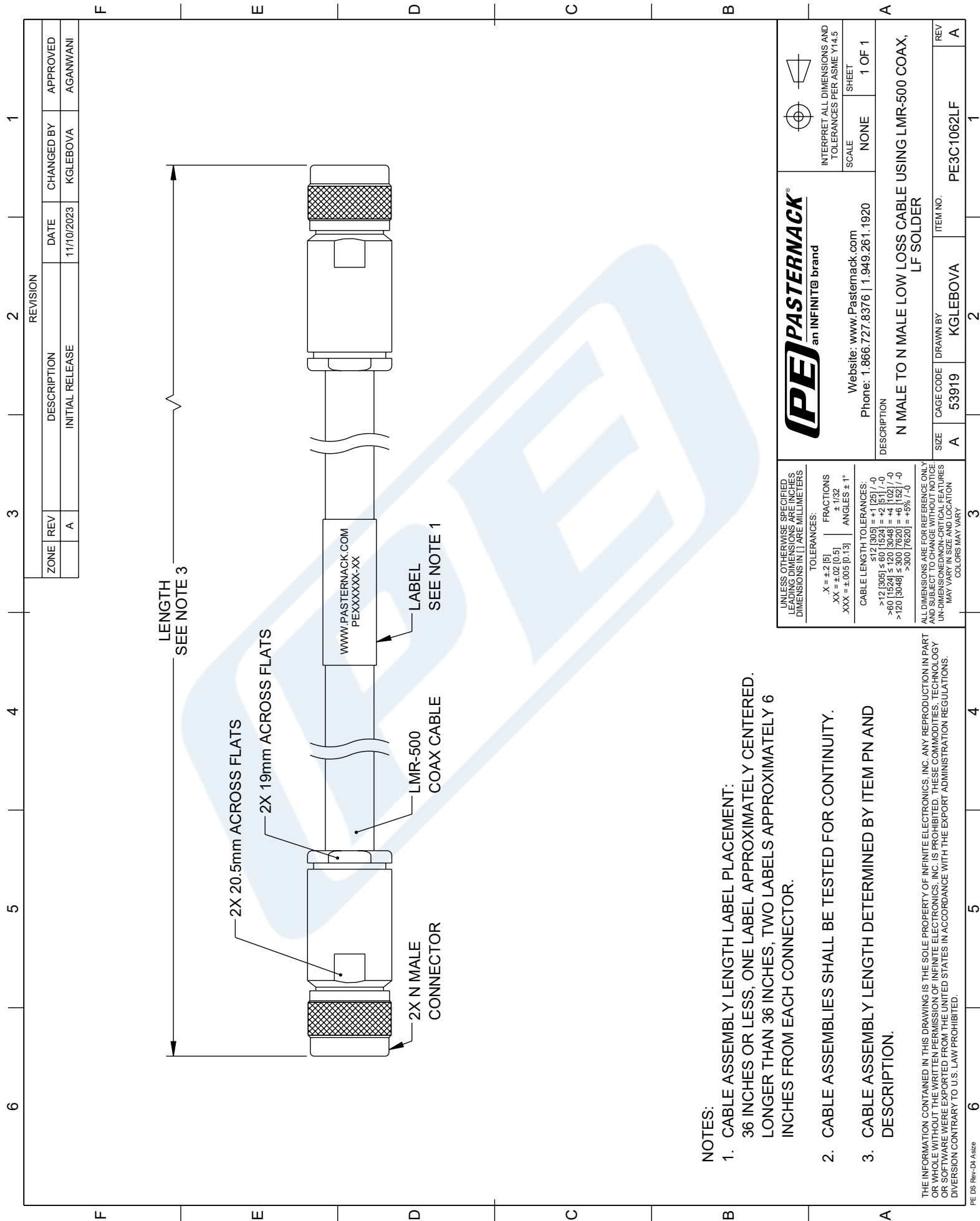

ZONE		REV	DESCRIPTION	DATE	CHANGED BY	APPROVED
		A	INITIAL RELEASE	11/10/2023	KGLEBOVA	AGANWANI

(PE) PASTERNAK
an INFINIT@ brand

Website: www.Pasternack.com
Phone: 1.866.727.8376 | 1.949.261.1920

INTERPRET ALL DIMENSIONS AND TOLERANCES PER ASME Y14.5

SCALE: NONE SHEET: 1 OF 1

DESCRIPTION:
N MALE TO N MALE LOW LOSS CABLE USING LMR-500 COAX, LF SOLDER

SIZE: A CAGE CODE: 53919 DRAWN BY: KGLEBOVA ITEM NO.: PE3C1062LF REV: A

UNLESS OTHERWISE SPECIFIED, ALL DIMENSIONS ARE IN INCHES. DIMENSIONS IN [] ARE MILLIMETERS.

TOLERANCES:
 .X = ±.2 [5]
 .XX = ±.02 [0.5]
 .XXX = ±.005 [0.13]

FRACTIONS:
 ± 1/32
 ANGLES ± 1°

CABLE LENGTH TOLERANCES:
 >12 [305] ≤ 517 [1304] = ±.125 / -0
 >60 [1524] ≤ 120 [3048] = ±.100 / -0
 >120 [3048] ≤ 300 [7620] = ±.152 / -0
 >300 [7620] = ±.5% / -0

ALL DIMENSIONS ARE FOR REFERENCE ONLY. UNDIMENSIONED CRITICAL FEATURES MAY VARY IN SIZE AND LOCATION. COLORS MAY VARY.

- NOTES:**
- CABLE ASSEMBLY LENGTH LABEL PLACEMENT: 36 INCHES OR LESS, ONE LABEL APPROXIMATELY CENTERED. LONGER THAN 36 INCHES, TWO LABELS APPROXIMATELY 6 INCHES FROM EACH CONNECTOR.
 - CABLE ASSEMBLIES SHALL BE TESTED FOR CONTINUITY.
 - CABLE ASSEMBLY LENGTH DETERMINED BY ITEM PN AND DESCRIPTION.

THE INFORMATION CONTAINED IN THIS DRAWING IS THE SOLE PROPERTY OF INFINITE ELECTRONICS, INC. ANY REPRODUCTION IN PART OR WHOLE WITHOUT THE WRITTEN PERMISSION OF INFINITE ELECTRONICS, INC. IS PROHIBITED. THESE COMMODITIES, TECHNOLOGY OR SOFTWARE WERE EXPORTED FROM THE UNITED STATES IN ACCORDANCE WITH THE EXPORT ADMINISTRATION REGULATIONS. DIVERSION CONTRARY TO U.S. LAW PROHIBITED.