



MMCX Plug to SMA Female Bulkhead Cable Using PE-P086 Coax with HeatShrink

RF Cable Assemblies Technical Data Sheet

PE3C3039/HS

Configuration

- Connector 1: MMCX Plug
- Connector 2: SMA Female Bulkhead
- Cable Type: PE-P086

Features

- Max Frequency 6 GHz
- Shielding Effectivity > 110 dB
- 70% Phase Velocity
- Double Shielded
- FEP Jacket

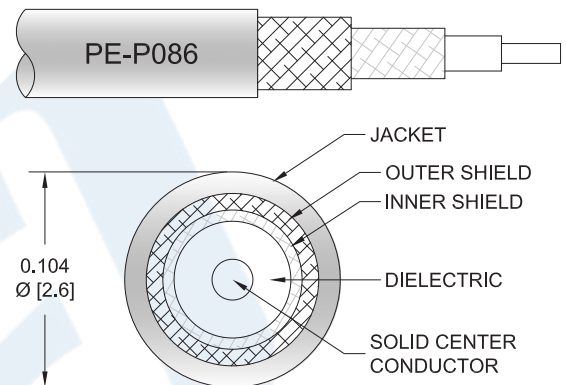

Applications

- General Purpose
- Laboratory Use

Description

Pasternack's PE3C3039/HS MMCX plug to SMA female bulkhead cable using PE-P086 coax is part of our full line of RF components available for same-day shipping. Pasternack's flexible RF cable assemblies are ideal for applications where tight bends and flexure are required. This Pasternack MMCX to SMA cable assembly has a plug to female gender configuration with 50 ohm flexible PE-P086 coax. The PE3C3039/HS MMCX plug to SMA female cable assembly operates to 6 GHz. Our RF cable assembly with SMA bulkhead interface allows designers to create external connections on their product enclosures, and can be used in a variety of other rack mount and panel mount applications. The double shielding of this Pasternack cable assembly provides excellent shielding effectiveness of better than 110 dB.

Custom versions of most RF cable assemblies can be built and shipped same day. Custom cable assembly lengths can be obtained by specifying the desired length on the web site at time of order or by contacting a sales representative. Other available RF cable assembly value added services include connector orientation or clocking, heat shrink booting and custom labeling. RF testing can also be performed to document the electrical performance of your cable assembly.

Click the following link (or enter part number in "SEARCH" on website) to obtain additional part information including price, inventory and certifications: [MMCX Plug to SMA Female Bulkhead Cable Using PE-P086 Coax with HeatShrink PE3C3039/HS](#)



MMCX Plug to SMA Female Bulkhead Cable Using PE-P086 Coax with HeatShrink

RF Cable Assemblies Technical Data Sheet

PE3C3039/HS

Electrical Specifications

Description	Minimum	Typical	Maximum	Units
Frequency Range	DC		6	GHz
VSWR			1.4:1	
Velocity of Propagation		70		%
RF Shielding	110			dB
Capacitance		29.4 [96.46]		pF/ft [pF/m]

Specifications by Frequency

Description	F1	F2	F3	F4	F5	Units
Frequency	1	2	2.5	5	6	GHz
Insertion Loss (Typ.)	0.211	0.305	0.338	0.503	0.551	dB/ft
	0.69	1	1.11	1.65	1.81	dB/m

Electrical Specification Notes:

Insertion Loss does not include the loss of the connectors. Insertion Loss is estimated as 0.1 dB for the straight connector.

Mechanical Specifications

Cable Assembly

Weight 0.029 lbs [13.15 g]

Cable

Cable Type PE-P086
 Impedance 50 Ohms
 Inner Conductor Type Solid
 Inner Conductor Material and Plating Copper Clad Steel, Silver
 Dielectric Type PTFE
 Number of Shields 2
 Shield Layer 1 Silver Plated Copper Tape
 Shield Layer 2 Silver Plated Copper Braid
 Jacket Material FEP, Blue
 Jacket Diameter 0.104 in [2.64 mm]

Repeated Minimum Bend Radius 0.5 in [12.7 mm]

Click the following link (or enter part number in "SEARCH" on website) to obtain additional part information including price, inventory and certifications: [MMCX Plug to SMA Female Bulkhead Cable Using PE-P086 Coax with HeatShrink PE3C3039/HS](#)



MMCX Plug to SMA Female Bulkhead Cable
Using PE-P086 Coax with HeatShrink

RF Cable Assemblies Technical Data Sheet

PE3C3039/HS

Connectors

Description	Connector 1	Connector 2
Type	MMCX Plug	SMA Female Bulkhead
Specification		MIL-STD-348A
Impedance	50 Ohms	50 Ohms
Contact Material and Plating	Brass, Gold	Beryllium Copper, Gold
Contact Plating Specification		50 µin minimum
Dielectric Type	PTFE	PTFE
Body Material and Plating	Brass, Gold	Stainless Steel, Gold
Body Plating Specification		30 µin minimum

Environmental Specifications

Temperature

Operating Range

-55 to +165 deg C

Compliance Certifications (see [product page](#) for current document)

Plotted and Other Data

Notes:

Click the following link (or enter part number in "SEARCH" on website) to obtain additional part information including price, inventory and certifications: [MMCX Plug to SMA Female Bulkhead Cable Using PE-P086 Coax with HeatShrink PE3C3039/HS](#)



MMCX Plug to SMA Female Bulkhead Cable
Using PE-P086 Coax with HeatShrink

RF Cable Assemblies Technical Data Sheet

PE3C3039/HS

How to Order

Part Number Configuration:

PE3C3039/HS - xx uu

Unit of Measure:
cm = Centimeters
<blank> = Inches
Length
Base Number

Example: PE3C3039/HS-12 = 12 inches long cable
PE3C3039/HS-100cm = 100 cm long cable

MMCX Plug to SMA Female Bulkhead Cable Using PE-P086 Coax with HeatShrink from Pasternack Enterprises has same day shipment for domestic and International orders. Our RF, microwave and millimeter wave products maintain a 99.4% availability and are part of the broadest selection in the industry.

Click the following link (or enter part number in "SEARCH" on website) to obtain additional part information including price, inventory and certifications: [MMCX Plug to SMA Female Bulkhead Cable Using PE-P086 Coax with HeatShrink PE3C3039/HS](#)

URL: <https://www.pasternack.com/mmcx-plug-to-sma-female-bulkhead-cable-using-pe-p086-with-heatshrink-pe3c3039-hs-p.aspx>

The information contained in this document is accurate to the best of our knowledge and representative of the part described herein. It may be necessary to make modifications to the part and/or the documentation of the part, in order to implement improvements. Pasternack reserves the right to make such changes as required. Unless otherwise stated, all specifications are nominal. Pasternack does not make any representation or warranty regarding the suitability of the part described herein for any particular purpose, and Pasternack does not assume any liability arising out of the use of any part or documentation.

PE3C3039/HS CAD Drawing

MMCX Plug to SMA Female Bulkhead Cable Using PE-P086 Coax with HeatShrink

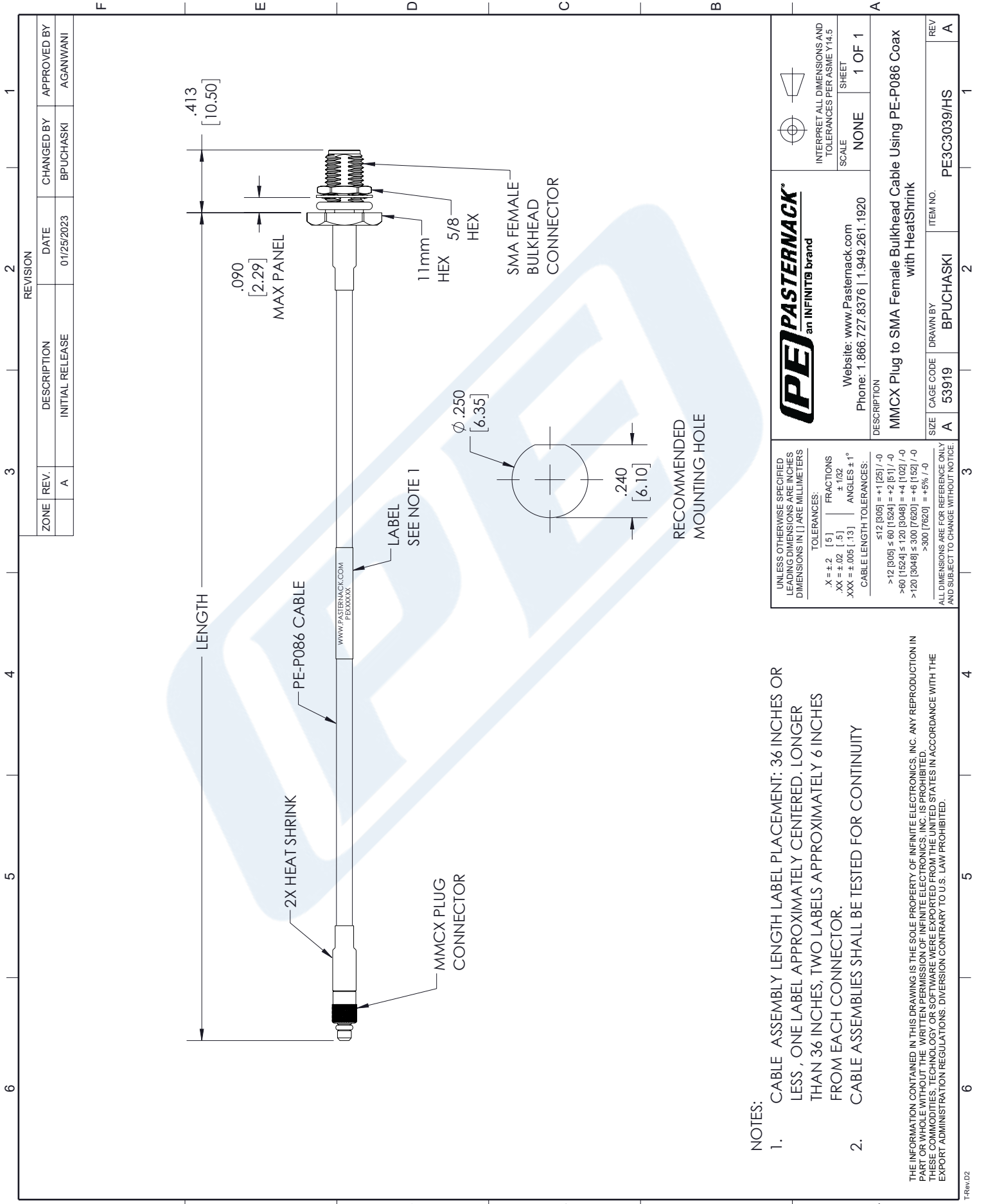

NOTES:

1. CABLE ASSEMBLY LENGTH LABEL PLACEMENT: 36 INCHES OR LESS, ONE LABEL APPROXIMATELY CENTERED. LONGER THAN 36 INCHES, TWO LABELS APPROXIMATELY 6 INCHES FROM EACH CONNECTOR.
2. CABLE ASSEMBLIES SHALL BE TESTED FOR CONTINUITY

THE INFORMATION CONTAINED IN THIS DRAWING IS THE SOLE PROPERTY OF INFINITE ELECTRONICS, INC. ANY REPRODUCTION IN PART OR WHOLE WITHOUT THE WRITTEN PERMISSION OF INFINITE ELECTRONICS, INC. IS PROHIBITED. THESE COMMODITIES, TECHNOLOGY OR SOFTWARE WERE EXPORTED FROM THE UNITED STATES IN ACCORDANCE WITH THE EXPORT ADMINISTRATION REGULATIONS. DIVERSION CONTRARY TO U.S. LAW PROHIBITED.

UNLESS OTHERWISE SPECIFIED LEADING DIMENSIONS ARE INCHES DIMENSIONS IN [] ARE MILLIMETERS	
TOLERANCES:	
X = ±.2 [5]	FRACTIONS ± 1/32
.XX = ±.02 [.5]	ANGLES ± 1°
.XXX = ±.005 [.13]	CABLE LENGTH TOLERANCES:
	≤12 [305] = +1 [25] / -0
	>12 [305] ≤ 60 [1524] = +2 [51] / -0
	>60 [1524] ≤ 120 [3048] = +4 [102] / -0
	>120 [3048] ≤ 300 [7620] = +6 [152] / -0
	>300 [7620] = +5% / -0
ALL DIMENSIONS ARE FOR REFERENCE ONLY AND SUBJECT TO CHANGE WITHOUT NOTICE.	

PE PASTERNAK
an INFINITB brand

Website: www.Pasternack.com
Phone: 1.866.727.8376 | 1.949.261.1920

DESCRIPTION
MMCX Plug to SMA Female Bulkhead Cable Using PE-P086 Coax with HeatShrink

INTERPRET ALL DIMENSIONS AND TOLERANCES PER ASME Y14.5
SCALE NONE
SHEET 1 OF 1

SIZE	CAGE CODE	DRAWN BY	ITEM NO.
A	53919	BPUCHASKI	PE3C3039/HS