



N Male to N Male Low Loss Cable Using LMR-200 Coax with Times Microwave Components, LF Solder

TECHNICAL DATA SHEET

PE3C3044LF

Configuration

- Connector 1: N Male
- Connector 2: N Male
- Cable Type: LMR-200
- Coax Flex Type: Flexible

Features

- Max Frequency 5.8 GHz
- Double Shielded
- PE Jacket

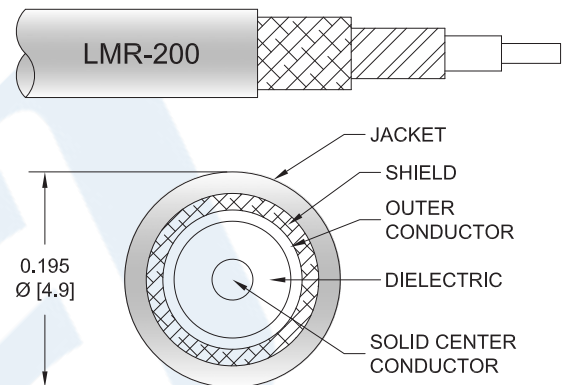

Applications

- General Purpose
- Laboratory Use

Description

Pasternack's PE3C3044LF type N male to type N male cable using LMR-200 coax is part of our full line of RF components available for same-day shipping. Pasternack's flexible RF cable assemblies are ideal for applications where tight bends and flexure are required. This Pasternack type N to type N cable assembly has a male to male gender configuration with 50 ohm flexible LMR-200 coax. The PE3C3044LF type N male to type N male cable assembly operates to 5.8 GHz. The double shielding of this Pasternack cable assembly provides excellent shielding effectiveness.

Custom versions of most RF cable assemblies can be built and shipped same day. Custom cable assembly lengths can be obtained by specifying the desired length on the web site at time of order or by contacting a sales representative. Other available RF cable assembly value added services include connector orientation or clocking, heat shrink booting and custom labeling. RF testing can also be performed to document the electrical performance of your cable assembly.

Click the following link (or enter part number in "SEARCH" on website) to obtain additional part information including price, inventory and certifications: [N Male to N Male Low Loss Cable Using LMR-200 Coax with Times Microwave Components, LF Solder PE3C3044LF](#)



N Male to N Male Low Loss Cable Using LMR-200 Coax with Times Microwave Components, LF Solder

TECHNICAL DATA SHEET

PE3C3044LF

Electrical Specifications

Description	Minimum	Typical	Maximum	Units
Frequency Range	DC		5.8	GHz
VSWR			1.4:1	

Specifications by Frequency

Part Number	Length	Description	F1	F2	F3	F4	F5	Units	Weight (lbs)
			Frequency	250	500	1000	2500	5800	
PE3C3044LF	Custom Lengths Available	Insertion Loss (Typ.)	0.05	0.07	0.1	0.16	0.26	dB/ft	
			0.17	0.23	0.33	0.53	0.86	dB/m	
PE3C3044LF-24	24 inch	Insertion Loss (Typ.)	0.3	0.34	0.4	0.52	0.72	dB	0.07
PE3C3044LF-36	36 inch	Insertion Loss (Typ.)	0.35	0.41	0.5	0.68	0.98	dB	0.09
PE3C3044LF-48	48 inch	Insertion Loss (Typ.)	0.4	0.48	0.6	0.84	1.24	dB	0.11
PE3C3044LF-60	60 inch	Insertion Loss (Typ.)	0.45	0.55	0.7	1	1.5	dB	0.14
PE3C3044LF-72	72 inch	Insertion Loss (Typ.)	0.5	0.62	0.8	1.16	1.76	dB	0.16

The insertion loss data for the base model does not include loss due to the connectors. Each length includes insertion loss due to the connectors.

Loss due to Connector 1:	0.1 dB
Loss due to Connector 2:	0.1 dB
Base Weight:	0.047 pounds
Additional Weight per Inch:	0.00184 pounds

Electrical Specification Notes:

Insertion Loss does not include the loss of the connectors. Insertion Loss is estimated as 0.1 dB per connector.

Mechanical Specifications

Cable Assembly

Weight 0.19 lbs [86.18 g]

Click the following link (or enter part number in "SEARCH" on website) to obtain additional part information including price, inventory and certifications: [N Male to N Male Low Loss Cable Using LMR-200 Coax with Times Microwave Components, LF Solder PE3C3044LF](#)



N Male to N Male Low Loss Cable Using LMR-200 Coax with Times Microwave Components, LF Solder

TECHNICAL DATA SHEET

PE3C3044LF

Cable

Cable Type	LMR-200
Impedance	50 Ohms
Inner Conductor Type	Solid
Inner Conductor Material and Plating	Copper
Dielectric Type	PE (F)
Number of Shields	2
Shield Layer 1	Aluminum Tape
Shield Layer 2	Tinned Copper Braid
Jacket Material	PE, Black
Jacket Diameter	0.195 in [4.95 mm]
One Time Minimum Bend Radius	0.5 in [12.7 mm]
Repeated Minimum Bend Radius	2 in [50.8 mm]
Bending Moment	0.2 lbs-ft [0.27 N-m]
Flat Plate Crush	15 lbs/in [0.27 Kg/mm]
Tensile Strength	40 lbs [18.14 Kg]

Connectors

Description	Connector 1	Connector 2
Type	N Male Threaded	N Male Threaded
Specification	MIL-STD-348	MIL-STD-348
Impedance	50 Ohms	50 Ohms
Contact Material and Plating	Brass, Gold	Brass, Gold
Dielectric Type	PTFE	PTFE
Body Material and Plating	Brass, Tri-Metal	Brass, Tri-Metal
Coupling Nut Material and Plating	Phosphor Bronze	Phosphor Bronze
Hex Size	13/16 Inch	13/16 Inch

Environmental Specifications

Temperature

Operating Range -40 to +85 deg C

Compliance Certifications (see [product page](#) for current document)

Plotted and Other Data

Notes:

Click the following link (or enter part number in "SEARCH" on website) to obtain additional part information including price, inventory and certifications: [N Male to N Male Low Loss Cable Using LMR-200 Coax with Times Microwave Components, LF Solder PE3C3044LF](#)



N Male to N Male Low Loss Cable Using LMR-200 Coax with Times Microwave Components, LF Solder

TECHNICAL DATA SHEET

PE3C3044LF

How to Order

Part Number Configuration:

PE3C3044LF - xx uu

Unit of Measure:
cm = Centimeters
<blank> = Inches
Length
Base Number

Example: PE3C3044LF-12 = 12 inches long cable
PE3C3044LF-100cm = 100 cm long cable

N Male to N Male Low Loss Cable Using LMR-200 Coax with Times Microwave Components, LF Solder from Pasternack Enterprises has same day shipment for domestic and International orders. Our RF, microwave and millimeter wave products maintain a 99.4% availability and are part of the broadest selection in the industry.

Click the following link (or enter part number in "SEARCH" on website) to obtain additional part information including price, inventory and certifications: [N Male to N Male Low Loss Cable Using LMR-200 Coax with Times Microwave Components, LF Solder PE3C3044LF](#)

URL: <https://www.pasternack.com/n-male-to-n-male-low-loss-cable-using-lmr-200-lf-solder-pe3c3044lf-p.aspx>

The information contained in this document is accurate to the best of our knowledge and representative of the part described herein. It may be necessary to make modifications to the part and/or the documentation of the part, in order to implement improvements. Pasternack reserves the right to make such changes as required. Unless otherwise stated, all specifications are nominal. Pasternack does not make any representation or warranty regarding the suitability of the part described herein for any particular purpose, and Pasternack does not assume any liability arising out of the use of any part or documentation.

PE3C3044LF CAD Drawing

N Male to N Male Low Loss Cable Using LMR-200 Coax with Times Microwave Components, LF Solder

F E D C B A

F E D C B A

1 2 3 4 5 6

ZONE		REV	DESCRIPTION	DATE	CHANGED BY	APPROVED
		A	INITIAL RELEASE	09/26/2023	DMAY	AGANWANI

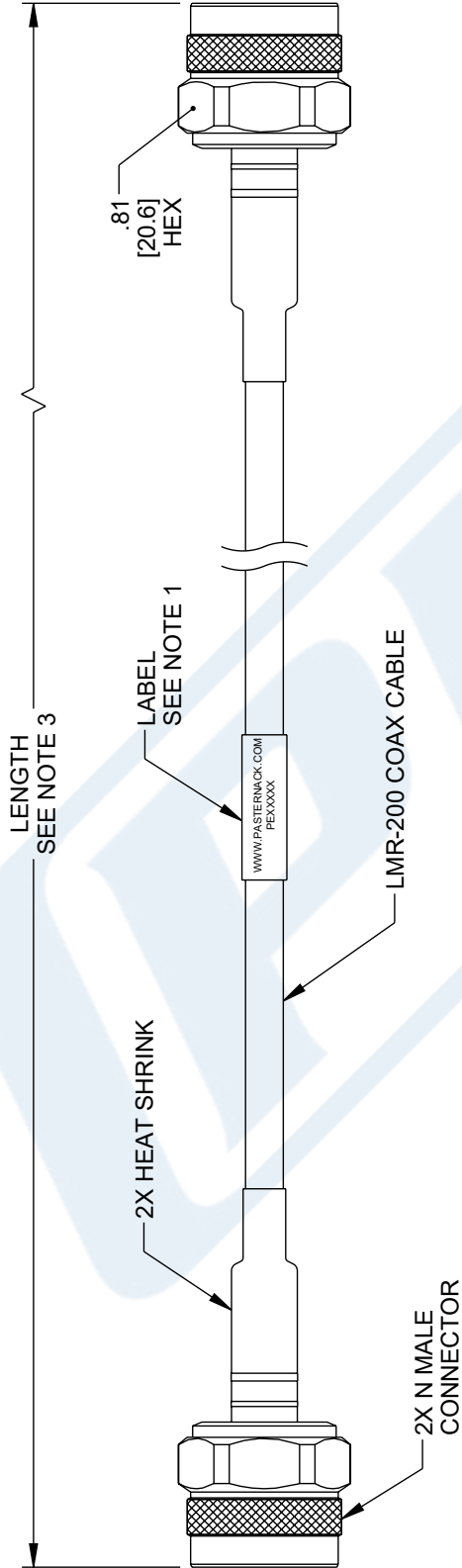

- NOTES:**
1. CABLE ASSEMBLY LENGTH LABEL PLACEMENT: 36 INCHES OR LESS, ONE LABEL APPROXIMATELY CENTERED, LONGER THAN 36 INCHES, TWO LABELS APPROXIMATELY 6 INCHES FROM EACH CONNECTOR.
 2. CABLE ASSEMBLIES SHALL BE TESTED FOR CONTINUITY.
 3. CABLE ASSEMBLY LENGTH DETERMINED BY ITEM PN AND DESCRIPTION.

UNLESS OTHERWISE SPECIFIED LEADING DIMENSIONS ARE INCHES DIMENSIONS IN [] ARE MILLIMETERS

TOLERANCES:	
.X = ±.2 [5]	FRACTIONS ± .732
.XX = ±.02 [0.5]	ANGLES ± 1°
.XXX = ±.005 [0.13]	CABLE LENGTH TOLERANCES:
<12 [305]	±.1 [25] / -0
>12 [305] ≤ 60 [1524]	±.2 [5] / -0
>60 [1524] ≤ 120 [3048]	±.4 [10.2] / -0
>120 [3048] ≤ 300 [7620]	±.6 [15.2] / -0
>300 [7620]	±.8 [20.3] / -0

ALL DIMENSIONS ARE FOR REFERENCE ONLY. UNLESS OTHERWISE SPECIFIED, ALL DIMENSIONS ARE NON-CRITICAL FEATURES. MAY VARY IN SIZE AND LOCATION. COLORS MAY VARY.

PE PASTERNAK
an INFINITI@ brand

Website: www.Pasternack.com
Phone: 1.866.727.8376 | 1.949.261.1920

DESCRIPTION
N MALE TO N MALE LOW LOSS CABLE USING LMR-200 COAX WITH TIMES MICROWAVE COMPONENTS, LF SOLDER

INTERPRET ALL DIMENSIONS AND TOLERANCES PER ASME Y14.5

SCALE	NONE	SHEET	1 OF 1
-------	------	-------	--------

SIZE	CAGE CODE	DRAWN BY	ITEM NO.
A	53919	DMAY	PE3C3044LF

THE INFORMATION CONTAINED IN THIS DRAWING IS THE SOLE PROPERTY OF INFINITE ELECTRONICS, INC. ANY REPRODUCTION IN PART OR WHOLE WITHOUT THE WRITTEN PERMISSION OF INFINITE ELECTRONICS, INC. IS PROHIBITED. THESE COMMODITIES, TECHNOLOGY OR SOFTWARE WERE EXPORTED FROM THE UNITED STATES IN ACCORDANCE WITH THE EXPORT ADMINISTRATION REGULATIONS. DIVERSION CONTRARY TO U.S. LAW PROHIBITED.