



N Male to N Male Low Loss Cable Using LMR-400 Coax With Times Microwave Components with HeatShrink

RF Cable Assemblies Technical Data Sheet

PE3C3565/HS

Configuration

- Connector 1: N Male
- Connector 2: N Male
- Cable Type: LMR-400

Features

- Max Frequency 6 GHz
- Shielding Effectivity > 90 dB
- 85% Phase Velocity
- Double Shielded
- PE Jacket

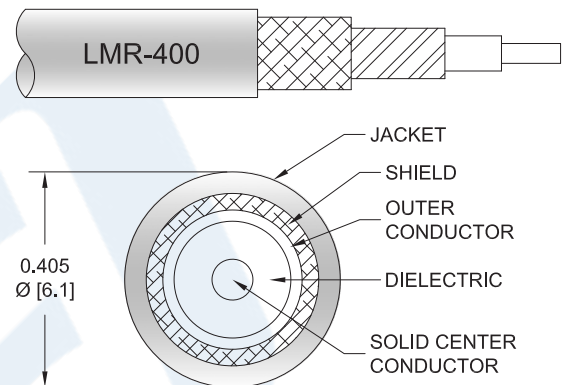

Applications

- General Purpose
- Laboratory Use

Description

Pasternack's PE3C3565/HS type N male to type N male cable using LMR-400 coax is part of our full line of RF components available for same-day shipping. Pasternack's flexible RF cable assemblies are ideal for applications where tight bends and flexure are required. This Pasternack type N to type N cable assembly has a male to male gender configuration with 50 ohm flexible LMR-400 coax. The PE3C3565/HS type N male to type N male cable assembly operates to 6 GHz. The double shielding of this Pasternack cable assembly provides excellent shielding effectiveness of better than 90 dB.

Custom versions of most RF cable assemblies can be built and shipped same day. Custom cable assembly lengths can be obtained by specifying the desired length on the web site at time of order or by contacting a sales representative. Other available RF cable assembly value added services include connector orientation or clocking, heat shrink booting and custom labeling. RF testing can also be performed to document the electrical performance of your cable assembly.

Click the following link (or enter part number in "SEARCH" on website) to obtain additional part information including price, inventory and certifications: [N Male to N Male Low Loss Cable Using LMR-400 Coax With Times Microwave Components with HeatShrink PE3C3565/HS](#)



N Male to N Male Low Loss Cable Using LMR-400 Coax With Times Microwave Components with HeatShrink

RF Cable Assemblies Technical Data Sheet

PE3C3565/HS

Electrical Specifications

Description	Minimum	Typical	Maximum	Units
Frequency Range	DC		6	GHz
VSWR			1.4:1	
Velocity of Propagation		85		%
RF Shielding	90			dB
Group Delay		1.2 [3.94]		ns/ft [ns/m]
Capacitance		23.9 [78.41]		pF/ft [pF/m]
Inductance		0.06 [0.2]		uH/ft [uH/m]
DC Resistance Inner Conductor		1.39 [4.56]		Ω/1000ft [Ω/Km]
DC Resistance Outer Conductor		1.65 [5.41]		Ω/1000ft [Ω/Km]
Jacket Spark			8,000	Vrms

Specifications by Frequency

Description	F1	F2	F3	F4	F5	Units
Frequency	0.25	0.5	1	2.5	6	GHz
Insertion Loss (Typ.)	0.02	0.028	0.041	0.068	0.111	dB/ft
	0.07	0.09	0.13	0.22	0.36	dB/m

Electrical Specification Notes:

Insertion Loss does not include the loss of the connectors. Insertion Loss is estimated as 0.1 dB per connector.

Mechanical Specifications

Cable Assembly

Cable

Cable Type	LMR-400
Impedance	50 Ohms
Inner Conductor Type	Solid
Inner Conductor Material and Plating	Copper Clad Aluminum
Dielectric Type	PE (F)
Number of Shields	2
Shield Layer 1	Aluminum Tape
Shield Layer 2	Tinned Copper Braid
Jacket Material	PE, Black
Jacket Diameter	0.405 in [10.29 mm]

One Time Minimum Bend Radius	1 in [25.4 mm]
Repeated Minimum Bend Radius	4 in [101.6 mm]

Click the following link (or enter part number in "SEARCH" on website) to obtain additional part information including price, inventory and certifications: [N Male to N Male Low Loss Cable Using LMR-400 Coax With Times Microwave Components with HeatShrink PE3C3565/HS](#)



N Male to N Male Low Loss Cable Using LMR-400 Coax
With Times Microwave Components with HeatShrink

RF Cable Assemblies Technical Data Sheet

PE3C3565/HS

Bending Moment	0.5 lbs-ft [0.68 N-m]
Flat Plate Crush	40 lbs/in [0.71 Kg/mm]
Tensile Strength	160 lbs [72.57 Kg]

Connectors

Description	Connector 1	Connector 2
Type	N Male	N Male
Impedance	50 Ohms	50 Ohms
Contact Material and Plating	Beryllium Bronze, Gold	Beryllium Bronze, Gold
Contact Plating Specification	50µ in. minimum	50µ in. minimum
Dielectric Type	PTFE	PTFE
Body Material and Plating	Brass, Tri-Metal	Brass, Tri-Metal
Body Plating Specification	150µ in. minimum	150µ in. minimum
Coupling Nut Material and Plating	Brass, Tri-Metal	Brass, Tri-Metal
Coupling Nut Plating Specification	150µ in. minimum	150µ in. minimum
Hex Size	13/16 Inch	13/16 Inch

Environmental Specifications

Temperature

Operating Range -40 to +85 deg C

Compliance Certifications (see [product page](#) for current document)

Plotted and Other Data

Notes:

Click the following link (or enter part number in "SEARCH" on website) to obtain additional part information including price, inventory and certifications: [N Male to N Male Low Loss Cable Using LMR-400 Coax With Times Microwave Components with HeatShrink PE3C3565/HS](#)



N Male to N Male Low Loss Cable Using LMR-400 Coax With Times Microwave Components with HeatShrink

RF Cable Assemblies Technical Data Sheet

PE3C3565/HS

How to Order

Part Number Configuration:

PE3C3565/HS - xx uu

Unit of Measure:
cm = Centimeters
<blank> = Inches
Length
Base Number

Example: PE3C3565/HS-12 = 12 inches long cable
PE3C3565/HS-100cm = 100 cm long cable

N Male to N Male Low Loss Cable Using LMR-400 Coax With Times Microwave Components with HeatShrink from Pasternack Enterprises has same day shipment for domestic and International orders. Our RF, microwave and millimeter wave products maintain a 99.4% availability and are part of the broadest selection in the industry.

Click the following link (or enter part number in "SEARCH" on website) to obtain additional part information including price, inventory and certifications: [N Male to N Male Low Loss Cable Using LMR-400 Coax With Times Microwave Components with HeatShrink PE3C3565/HS](#)

URL: <https://www.pasternack.com/n-male-to-n-male-low-loss-cable-using-lmr-400-with-heatshrink-pe3c3565-hs-p.aspx>

The information contained in this document is accurate to the best of our knowledge and representative of the part described herein. It may be necessary to make modifications to the part and/or the documentation of the part, in order to implement improvements. Pasternack reserves the right to make such changes as required. Unless otherwise stated, all specifications are nominal. Pasternack does not make any representation or warranty regarding the suitability of the part described herein for any particular purpose, and Pasternack does not assume any liability arising out of the use of any part or documentation.

PE3C3565/HS CAD Drawing

N Male to N Male Low Loss Cable Using LMR-400 Coax With Times Microwave Components with HeatShrink

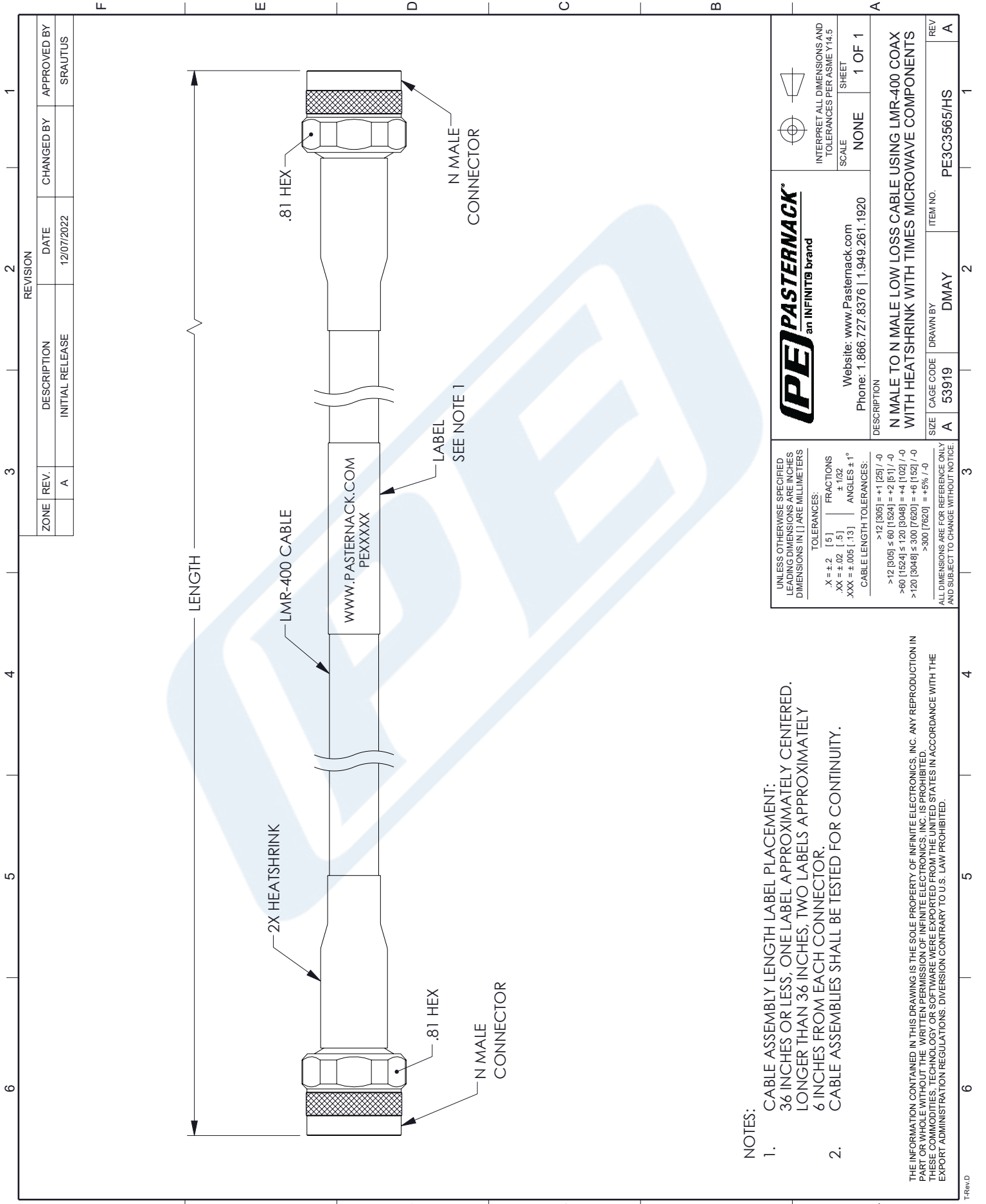

NOTES:

1. CABLE ASSEMBLY LENGTH LABEL PLACEMENT:
36 INCHES OR LESS, ONE LABEL APPROXIMATELY CENTERED.
LONGER THAN 36 INCHES, TWO LABELS APPROXIMATELY
6 INCHES FROM EACH CONNECTOR.
2. CABLE ASSEMBLIES SHALL BE TESTED FOR CONTINUITY.

THE INFORMATION CONTAINED IN THIS DRAWING IS THE SOLE PROPERTY OF INFINITE ELECTRONICS, INC. ANY REPRODUCTION IN PART OR WHOLE WITHOUT THE WRITTEN PERMISSION OF INFINITE ELECTRONICS, INC. IS PROHIBITED. THESE COMMODITIES, TECHNOLOGY OR SOFTWARE WERE EXPORTED FROM THE UNITED STATES IN ACCORDANCE WITH THE EXPORT ADMINISTRATION REGULATIONS. DIVERSION CONTRARY TO U.S. LAW PROHIBITED.

ZONE	REV.	DESCRIPTION	DATE	CHANGED BY	APPROVED BY
	A	INITIAL RELEASE	12/07/2022		SRAUTUS

ZONE	REV.	DESCRIPTION	DATE	CHANGED BY	APPROVED BY
	A	INITIAL RELEASE	12/07/2022		SRAUTUS

<p>Website: www.Pasternack.com Phone: 1.866.727.8376 1.949.261.1920</p>	<p>INTERPRET ALL DIMENSIONS AND TOLERANCES PER ASME Y14.5</p> <p>SCALE: NONE</p> <p>SHEET: 1 OF 1</p>
	<p>DESCRIPTION: N MALE TO N MALE LOW LOSS CABLE USING LMR-400 COAX WITH HEATSHRINK WITH TIMES MICROWAVE COMPONENTS</p>
<p>UNLESS OTHERWISE SPECIFIED LEADING DIMENSIONS ARE INCHES DIMENSIONS IN [] ARE MILLIMETERS</p> <p>TOLERANCES:</p> <p>X = ±.2 [.5] FRACTIONS .XX = ±.02 [.5] ANGLES ± 1° XXX = ±.005 [.13]</p> <p>CABLE LENGTH TOLERANCES:</p> <p>>12 [305] = +1 [25] / -0 >12 [305] ≤ 60 [1524] = +2 [51] / -0 >60 [1524] ≤ 120 [3048] = +4 [102] / -0 >120 [3048] ≤ 300 [7620] = +6 [152] / -0 >300 [7620] = +5% / -0</p> <p>ALL DIMENSIONS ARE FOR REFERENCE ONLY AND SUBJECT TO CHANGE WITHOUT NOTICE.</p>	<p>ITEM NO. PE3C3565/HS</p>