



N Male Right Angle to TNC Male Right Angle Low Loss Cable Using LMR-400-DB Coax with Times Microwave Components

TECHNICAL DATA SHEET

PE3C4711

Configuration

- Connector 1: N Male Right Angle
- Connector 2: TNC Male Right Angle
- Cable Type: LMR-400-DB
- Coax Flex Type: Flexible

Features

- Max Frequency 6 GHz
- Shielding Effectivity > 90 dB
- 85% Phase Velocity
- Double Shielded
- PE Jacket

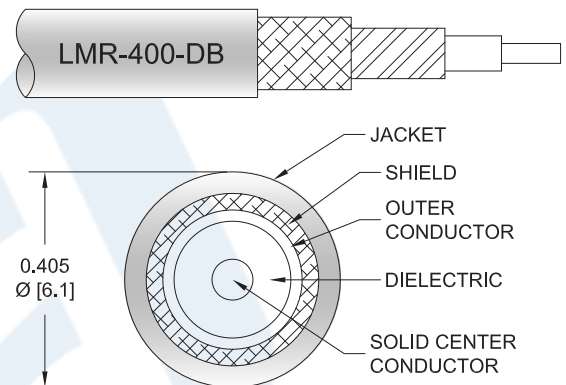

Applications

- General Purpose
- Laboratory Use

Description

Pasternack's PE3C4711 type N male right angle to TNC male right angle cable using LMR-400-DB coax is part of our full line of RF components available for same-day shipping. Pasternack's flexible RF cable assemblies are ideal for applications where tight bends and flexure are required. This Pasternack type N to TNC cable assembly has a male to male gender configuration with 50 ohm flexible LMR-400-DB coax. The PE3C4711 type N male to TNC male cable assembly operates to 6 GHz. The right angle type N and right angle TNC interfaces on the LMR-400-DB cable allow for easier connections in tight spaces. The double shielding of this Pasternack cable assembly provides excellent shielding effectiveness of better than 90 dB.

Custom versions of most RF cable assemblies can be built and shipped same day. Custom cable assembly lengths can be obtained by specifying the desired length on the web site at time of order or by contacting a sales representative. Other available RF cable assembly value added services include connector orientation or clocking, heat shrink booting and custom labeling. RF testing can also be performed to document the electrical performance of your cable assembly.

Click the following link (or enter part number in "SEARCH" on website) to obtain additional part information including price, inventory and certifications: [N Male Right Angle to TNC Male Right Angle Low Loss Cable Using LMR-400-DB Coax with Times Microwave Components PE3C4711](#)



N Male Right Angle to TNC Male Right Angle Low Loss Cable Using LMR-400-DB Coax with Times Microwave Components

TECHNICAL DATA SHEET

PE3C4711

Electrical Specifications

Description	Minimum	Typical	Maximum	Units
Frequency Range	DC		6	GHz
VSWR			1.4:1	
Velocity of Propagation		85		%
RF Shielding	90			dB
Group Delay		1.2 [3.94]		ns/ft [ns/m]
Capacitance		23.9 [78.41]		pF/ft [pF/m]
Inductance		0.06 [0.2]		uH/ft [uH/m]
DC Resistance Inner Conductor		1.39 [4.56]		Ω /1000ft [Ω /Km]
DC Resistance Outer Conductor		1.65 [5.41]		Ω /1000ft [Ω /Km]
Jacket Spark			8,000	Vrms

Specifications by Frequency

Part Number	Length	Description	F1	F2	F3	F4	F5	Units	Weight (lbs)
			Frequency						
PE3C4711	Custom Lengths Available	Insertion Loss (Typ.)	0.02	0.03	0.04	0.07	0.11	dB/ft	
			0.07	0.1	0.14	0.23	0.36	dB/m	
PE3C4711-12	12 inch	Insertion Loss (Typ.)	0.42	0.43	0.45	0.47	0.51	dB	0.316
PE3C4711-24	24 inch	Insertion Loss (Typ.)	0.44	0.46	0.49	0.54	0.62	dB	0.387
PE3C4711-36	36 inch	Insertion Loss (Typ.)	0.46	0.49	0.53	0.61	0.73	dB	0.457
PE3C4711-48	48 inch	Insertion Loss (Typ.)	0.48	0.52	0.57	0.68	0.84	dB	0.527
PE3C4711-60	60 inch	Insertion Loss (Typ.)	0.5	0.54	0.61	0.74	0.94	dB	0.597

The insertion loss data for the base model does not include loss due to the connectors. Each length includes insertion loss due to the connectors.

Loss due to Connector 1:	0.2 dB
Loss due to Connector 2:	0.2 dB
Base Weight:	0.316 pounds
Additional Weight per Inch:	0.00584 pounds

Mechanical Specifications

Cable Assembly

Weight 0.316 lbs [143.34 g]

Click the following link (or enter part number in "SEARCH" on website) to obtain additional part information including price, inventory and certifications: [N Male Right Angle to TNC Male Right Angle Low Loss Cable Using LMR-400-DB Coax with Times Microwave Components PE3C4711](#)



N Male Right Angle to TNC Male Right Angle Low Loss Cable Using LMR-400-DB Coax with Times Microwave Components

TECHNICAL DATA SHEET

PE3C4711

Cable

Cable Type	LMR-400-DB
Impedance	50 Ohms
Inner Conductor Type	Solid
Inner Conductor Material and Plating	Copper Clad Aluminum
Dielectric Type	PE (F)
Number of Shields	2
Shield Layer 1	Aluminum Tape
Shield Layer 2	Tinned Copper Braid
Jacket Material	PE, Black
Jacket Diameter	0.405 in [10.29 mm]
One Time Minimum Bend Radius	1 in [25.4 mm]
Repeated Minimum Bend Radius	4 in [101.6 mm]
Bending Moment	0.5 lbs-ft [0.68 N-m]
Flat Plate Crush	40 lbs/in [0.71 Kg/mm]
Tensile Strength	160 lbs [72.57 Kg]

Connectors

Description	Connector 1	Connector 2
Type	N Male Right Angle Threaded	TNC Male Right Angle Threaded
Impedance	50 Ohms	50 Ohms
Mating Cycles	500	
Contact Material and Plating	Brass, Gold	Brass, Silver
Dielectric Type	Teflon	PTFE
Body Material and Plating	Brass, Tri-Metal	Brass, Silver
Coupling Nut Material and Plating	Brass, Tri-Metal	Brass, Silver
Hex Size	13/16 inch	
Torque	30 in-lbs [3.39 Nm]	

Environmental Specifications

Temperature

Operating Range -40 to +85 deg C

Compliance Certifications (see [product page](#) for current document)

Plotted and Other Data

Notes:

Click the following link (or enter part number in "SEARCH" on website) to obtain additional part information including price, inventory and certifications: [N Male Right Angle to TNC Male Right Angle Low Loss Cable Using LMR-400-DB Coax with Times Microwave Components PE3C4711](#)



N Male Right Angle to TNC Male Right Angle Low Loss Cable Using LMR-400-DB Coax with Times Microwave Components

TECHNICAL DATA SHEET

PE3C4711

How to Order

Part Number Configuration:

PE3C4711

- **xx**

uu

Unit of Measure:
cm = Centimeters
<blank> = Inches
Length
Base Number

Example: PE3C4711-12 = 12 inches long cable
PE3C4711-100cm = 100 cm long cable

N Male Right Angle to TNC Male Right Angle Low Loss Cable Using LMR-400-DB Coax with Times Microwave Components from Pasternack Enterprises has same day shipment for domestic and International orders. Our RF, microwave and millimeter wave products maintain a 99.4% availability and are part of the broadest selection in the industry.

Click the following link (or enter part number in "SEARCH" on website) to obtain additional part information including price, inventory and certifications: [N Male Right Angle to TNC Male Right Angle Low Loss Cable Using LMR-400-DB Coax with Times Microwave Components PE3C4711](#)

URL: <https://www.pasternack.com/n-male-right-angle-to-tnc-male-low-loss-cable-using-lmr-400-db-pe3c4711-p.aspx>

The information contained in this document is accurate to the best of our knowledge and representative of the part described herein. It may be necessary to make modifications to the part and/or the documentation of the part, in order to implement improvements. Pasternack reserves the right to make such changes as required. Unless otherwise stated, all specifications are nominal. Pasternack does not make any representation or warranty regarding the suitability of the part described herein for any particular purpose, and Pasternack does not assume any liability arising out of the use of any part or documentation.

PE3C4711 CAD Drawing

N Male Right Angle to TNC Male Right Angle Low Loss Cable Using LMR-400-DB Coax with Times Microwave Components

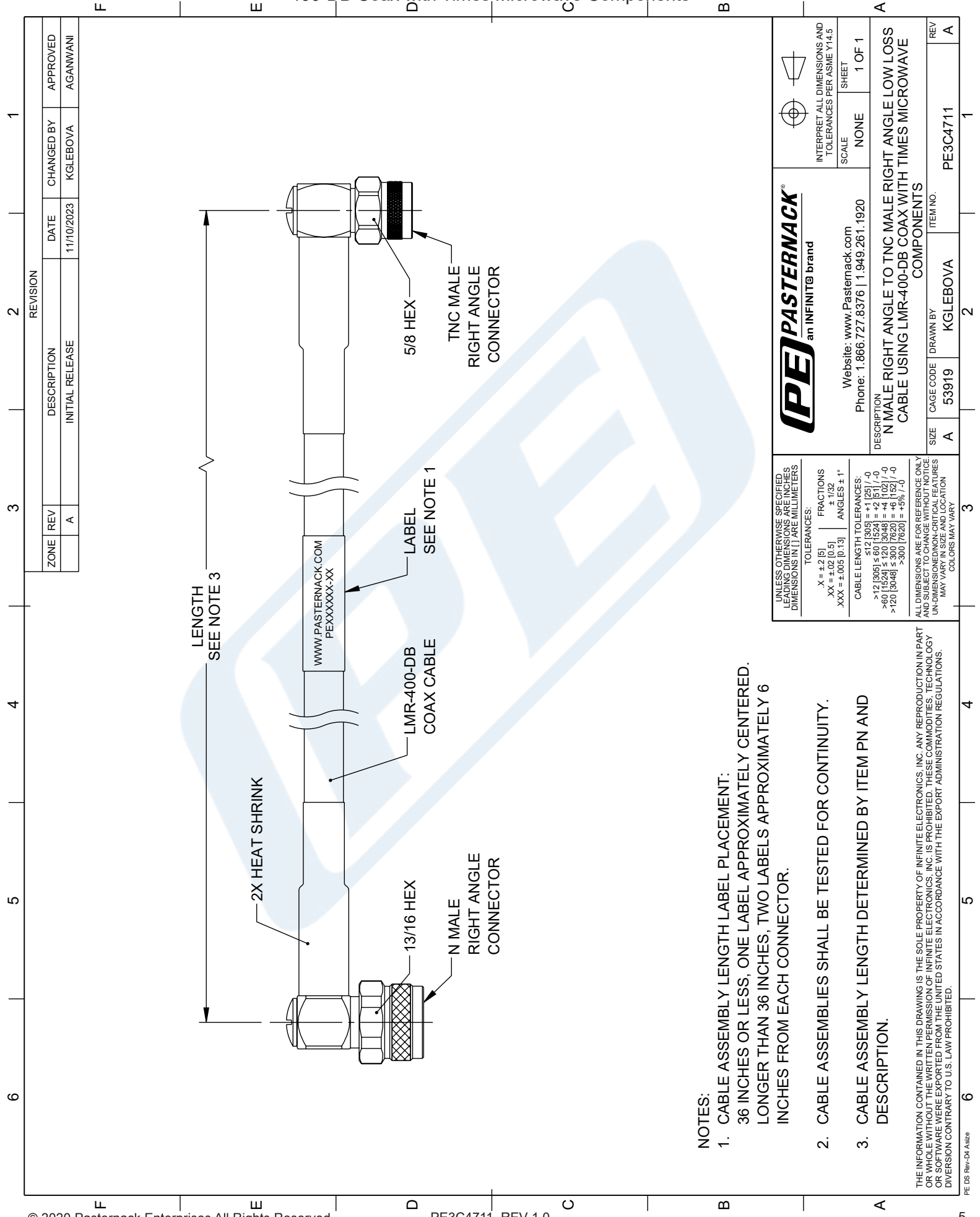

NOTES:

1. CABLE ASSEMBLY LENGTH LABEL PLACEMENT:
36 INCHES OR LESS, ONE LABEL APPROXIMATELY CENTERED.
LONGER THAN 36 INCHES, TWO LABELS APPROXIMATELY 6 INCHES FROM EACH CONNECTOR.
2. CABLE ASSEMBLIES SHALL BE TESTED FOR CONTINUITY.
3. CABLE ASSEMBLY LENGTH DETERMINED BY ITEM PN AND DESCRIPTION.

THE INFORMATION CONTAINED IN THIS DRAWING IS THE SOLE PROPERTY OF INFINITE ELECTRONICS, INC. ANY REPRODUCTION IN PART OR WHOLE WITHOUT THE WRITTEN PERMISSION OF INFINITE ELECTRONICS, INC. IS PROHIBITED. THESE COMMODITIES, TECHNOLOGY OR SOFTWARE WERE EXPORTED FROM THE UNITED STATES IN ACCORDANCE WITH THE EXPORT ADMINISTRATION REGULATIONS. DIVERSION CONTRARY TO U.S. LAW PROHIBITED.

ZONE		REVISION	
A	REV	DESCRIPTION	DATE
A		INITIAL RELEASE	11/10/2023

APPROVED	
CHANGED BY	AGANWANI
AGANWANI	

<p>PASTERNAK an INFINIT@ brand</p> <p>Website: www.Pasternack.com Phone: 1.866.727.8376 1.949.261.1920</p>	<p>INTERPRET ALL DIMENSIONS AND TOLERANCES PER ASME Y14.5</p>
	<p>SCALE: NONE</p> <p>SHEET: 1 OF 1</p>
<p>DESCRIPTION: N MALE RIGHT ANGLE TO TNC MALE RIGHT ANGLE LOW LOSS CABLE USING LMR-400-DB COAX WITH TIMES MICROWAVE COMPONENTS</p>	
<p>SIZE: A</p> <p>CAGE CODE: 53919</p> <p>DRAWN BY: KGLEBOVA</p> <p>ITEM NO.: PE3C4711</p>	<p>REV: A</p>

UNLESS OTHERWISE SPECIFIED, LEADING DIMENSIONS ARE IN INCHES. DIMENSIONS IN [] ARE MILLIMETERS.

TOLERANCES:
 .X = ±.2 [5] FRACTIONS ±.132
 .XX = ±.02 [0.5] ±.132
 .XXX = ±.005 [0.13] ANGLES ± 1°

CABLE LENGTH TOLERANCES:
 >12 [305] ≤ 6 [152] = ±.125 / -0
 >6 [152] ≤ 120 [3048] = ±.102 / -0
 >120 [3048] ≤ 300 [7620] = ±.152 / -0
 >300 [7620] = ±.5% / -0

ALL DIMENSIONS ARE FOR REFERENCE ONLY. UNDIMENSIONED CRITICAL FEATURES MAY VARY IN SIZE AND LOCATION. COLORS MAY VARY.