



BNC Male to UHF Male Low Loss Cable Using LMR-400-UF Coax

RF Cable Assemblies Technical Data Sheet

PE3C6740

Configuration

- Connector 1: BNC Male
- Connector 2: UHF Male
- Cable Type: LMR-400-UF

Features

- Max Frequency 4 GHz
- Shielding Effectivity > 90 dB
- 85% Phase Velocity
- Double Shielded
- TPE Jacket

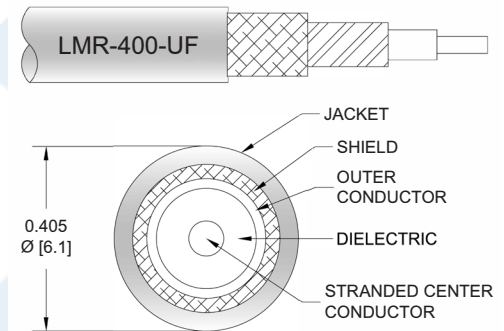

Applications

- General Purpose
- Laboratory Use

Description

Pasternack's PE3C6740 BNC male to UHF male cable using LMR-400-UF coax is part of our full line of RF components available for same-day shipping. Pasternack's flexible RF cable assemblies are ideal for applications where tight bends and flexure are required. This Pasternack BNC to UHF cable assembly has a male to male gender configuration with 50 ohm flexible LMR-400-UF coax. The PE3C6740 BNC male to UHF male cable assembly operates to 4 GHz. The double shielding of this Pasternack cable assembly provides excellent shielding effectiveness of better than 90 dB.

Custom versions of most RF cable assemblies can be built and shipped same day. Custom cable assembly lengths can be obtained by specifying the desired length on the web site at time of order or by contacting a sales representative. Other available RF cable assembly value added services include connector orientation or clocking, heat shrink booting and custom labeling. RF testing can also be performed to document the electrical performance of your cable assembly.

Click the following link (or enter part number in "SEARCH" on website) to obtain additional part information including price, inventory and certifications: [BNC Male to UHF Male Low Loss Cable Using LMR-400-UF Coax PE3C6740](#)



BNC Male to UHF Male Low Loss Cable Using LMR-400-UF Coax

RF Cable Assemblies Technical Data Sheet

PE3C6740

Electrical Specifications

Description	Minimum	Typical	Maximum	Units
Frequency Range	DC		4	GHz
VSWR			1.4:1	
Velocity of Propagation		85		%
RF Shielding	90			dB
Group Delay		1.2 [3.94]		ns/ft [ns/m]
Capacitance		23.9 [78.41]		pF/ft [pF/m]
Inductance		0.06 [0.2]		uH/ft [uH/m]
DC Resistance Inner Conductor		1.07 [3.51]		Ω /1000ft [Ω /Km]
DC Resistance Outer Conductor		1.65 [5.41]		Ω /1000ft [Ω /Km]
Jacket Spark			8,000	Vrms

Specifications by Frequency

Description	F1	F2	F3	F4	F5	Units
Frequency	0.1	0.25	0.5	1	4	GHz
Insertion Loss (Typ.)	0.014	0.023	0.034	0.049	0.103	dB/ft
	0.05	0.08	0.11	0.16	0.34	dB/m

Electrical Specification Notes:

Insertion Loss does not include the loss of the connectors. Insertion Loss is estimated as 0.1 dB per connector.

Mechanical Specifications

Cable Assembly

Weight 0.208 lbs [94.35 g]

Cable

Cable Type LMR-400-UF
 Impedance 50 Ohms
 Inner Conductor Type Stranded
 Inner Conductor Material and Plating Copper
 Dielectric Type PE (F)
 Number of Shields 2
 Shield Layer 1 Aluminum Tape
 Shield Layer 2 Tinned Copper Braid
 Jacket Material TPE, Black
 Jacket Diameter 0.405 in [10.29 mm]

One Time Minimum Bend Radius 1 in [25.4 mm]

Click the following link (or enter part number in "SEARCH" on website) to obtain additional part information including price, inventory and certifications: [BNC Male to UHF Male Low Loss Cable Using LMR-400-UF Coax PE3C6740](#)



BNC Male to UHF Male Low Loss Cable Using LMR-400-UF Coax

RF Cable Assemblies Technical Data Sheet

PE3C6740

Repeated Minimum Bend Radius	4 in [101.6 mm]
Bending Moment	0.38 lbs-ft [0.52 N-m]
Flat Plate Crush	20 lbs/in [0.36 Kg/mm]
Tensile Strength	160 lbs [72.57 Kg]

Connectors

Description	Connector 1	Connector 2
Type	BNC Male	UHF Male
Impedance	50 Ohms	50 Ohms
Mating Cycles	500	
Contact Material and Plating	Brass, Gold	Gold
Contact Plating Specification	50 microns	
Dielectric Type	PTFE	PTFE
Body Material and Plating	Brass, Tri-Metal	Brass, Nickel
Body Plating Specification	80 microns	
Coupling Nut Material and Plating	Brass, Tri-Metal	Brass, Nickel
Coupling Nut Plating Specification	80 microns	

Environmental Specifications

Temperature

Operating Range -40 to +85 deg C

Compliance Certifications (see [product page](#) for current document)

Plotted and Other Data

Notes:

Click the following link (or enter part number in "SEARCH" on website) to obtain additional part information including price, inventory and certifications: [BNC Male to UHF Male Low Loss Cable Using LMR-400-UF Coax PE3C6740](#)



BNC Male to UHF Male Low Loss Cable Using LMR-400-UF Coax

RF Cable Assemblies Technical Data Sheet

PE3C6740

How to Order

Part Number Configuration:

PE3C6740

- **xx**

uu

Unit of Measure:
cm = Centimeters
<blank> = Inches
Length
Base Number

Example: PE3C6740-12 = 12 inches long cable
PE3C6740-100cm = 100 cm long cable

BNC Male to UHF Male Low Loss Cable Using LMR-400-UF Coax from Pasternack Enterprises has same day shipment for domestic and International orders. Our RF, microwave and millimeter wave products maintain a 99.4% availability and are part of the broadest selection in the industry.

Click the following link (or enter part number in "SEARCH" on website) to obtain additional part information including price, inventory and certifications: [BNC Male to UHF Male Low Loss Cable Using LMR-400-UF Coax PE3C6740](#)

URL: <https://www.pasternack.com/bnc-male-to-uhf-male-low-loss-cable-using-lmr-400-uf-pe3c6740-p.aspx>

The information contained in this document is accurate to the best of our knowledge and representative of the part described herein. It may be necessary to make modifications to the part and/or the documentation of the part, in order to implement improvements. Pasternack reserves the right to make such changes as required. Unless otherwise stated, all specifications are nominal. Pasternack does not make any representation or warranty regarding the suitability of the part described herein for any particular purpose, and Pasternack does not assume any liability arising out of the use of any part or documentation.

PE3C6740 CAD Drawing

BNC Male to UHF Male Low Loss Cable Using LMR-400-UF Coax

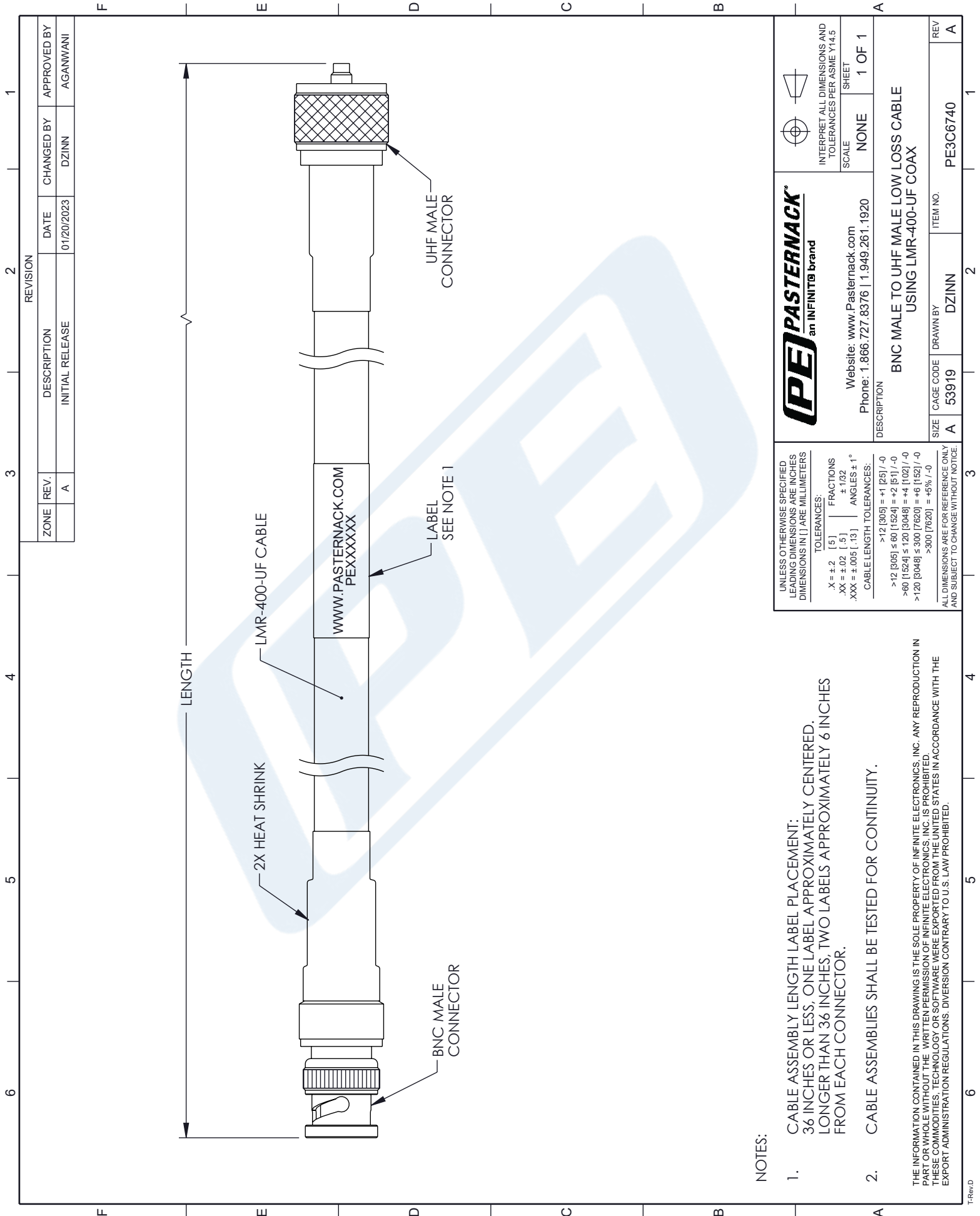

NOTES:

1. CABLE ASSEMBLY LENGTH LABEL PLACEMENT: 36 INCHES OR LESS, ONE LABEL APPROXIMATELY CENTERED. LONGER THAN 36 INCHES, TWO LABELS APPROXIMATELY 6 INCHES FROM EACH CONNECTOR.
 2. CABLE ASSEMBLIES SHALL BE TESTED FOR CONTINUITY.
- THE INFORMATION CONTAINED IN THIS DRAWING IS THE SOLE PROPERTY OF INFINITE ELECTRONICS, INC. ANY REPRODUCTION IN PART OR WHOLE WITHOUT THE WRITTEN PERMISSION OF INFINITE ELECTRONICS, INC. IS PROHIBITED. THESE COMMODITIES, TECHNOLOGY OR SOFTWARE WERE EXPORTED FROM THE UNITED STATES IN ACCORDANCE WITH THE EXPORT ADMINISTRATION REGULATIONS. DIVERSION CONTRARY TO U.S. LAW PROHIBITED.

 PASTERNAK an INFINIT® brand		INTERPRET ALL DIMENSIONS AND TOLERANCES PER ASME Y14.5 SCALE: NONE SHEET: 1 OF 1
Website: www.Pasternack.com Phone: 1.866.727.8376 1.949.261.1920		DESCRIPTION BNC MALE TO UHF MALE LOW LOSS CABLE USING LMR-400-UF COAX
CAGE CODE: 53919 DRAWN BY: DZINN ITEM NO.: PE3C6740		
UNLESS OTHERWISE SPECIFIED LEADING DIMENSIONS ARE INCHES DIMENSIONS IN [] ARE MILLIMETERS TOLERANCES: .X = ±.2 [.5] FRACTIONS ±.1/32 .XX = ±.02 [.5] ANGLES ± 1° .XXX = ±.005 [.13] CABLE LENGTH TOLERANCES: >12 [305] = +1 [25] / -0 >60 [1524] ≤ 60 [1524] = +2 [51] / -0 >120 [3048] ≤ 120 [3048] = +4 [102] / -0 >300 [7620] ≤ 300 [7620] = +6 [152] / -0 >300 [7620] = +5% / -0 ALL DIMENSIONS ARE FOR REFERENCE ONLY AND SUBJECT TO CHANGE WITHOUT NOTICE.		