



N Male to QMA Male Cable Using RG58 Coax

RF Cable Assemblies Technical Data Sheet

PE3C7692

Configuration

- Connector 1: N Male
- Connector 2: QMA Male
- Cable Type: RG58

Features

- Max Frequency 5 GHz
- 65.9% Phase Velocity
- PVC (NC) Jacket
- 500 Mating Cycles

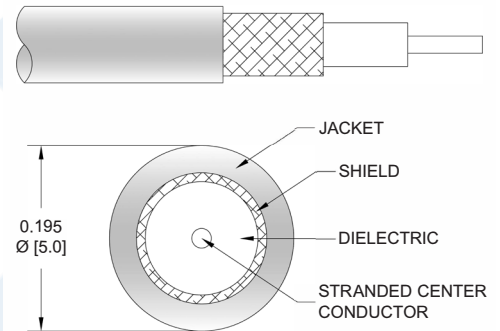

Applications

- General Purpose
- Laboratory Use

Description

Pasternack's PE3C7692 type N male to QMA male cable using RG58 coax is part of our full line of RF components available for same-day shipping. Pasternack's flexible RF cable assemblies are ideal for applications where tight bends and flexure are required. This Pasternack type N to QMA cable assembly has a male to male gender configuration with 50 ohm flexible RG58 coax. The PE3C7692 type N male to QMA male cable assembly operates to 5 GHz.

Custom versions of most RF cable assemblies can be built and shipped same day. Custom cable assembly lengths can be obtained by specifying the desired length on the web site at time of order or by contacting a sales representative. Other available RF cable assembly value added services include connector orientation or clocking, heat shrink booting and custom labeling. RF testing can also be performed to document the electrical performance of your cable assembly.

Click the following link (or enter part number in "SEARCH" on website) to obtain additional part information including price, inventory and certifications: [N Male to QMA Male Cable Using RG58 Coax PE3C7692](#)



N Male to QMA Male Cable Using RG58 Coax

RF Cable Assemblies Technical Data Sheet

PE3C7692

Electrical Specifications

Description	Minimum	Typical	Maximum	Units
Frequency Range	DC		5	GHz
VSWR			1.4:1	
Velocity of Propagation		65.9		%
Capacitance		30.8 [101.05]		pF/ft [pF/m]

Specifications by Frequency

Description	F1	F2	F3	F4	F5	Units
Frequency	0.25	0.5	1	2.5	5	GHz
Insertion Loss (Typ.)	0.07	0.11	0.2	0.35	0.6	dB/ft
	0.23	0.36	0.66	1.15	1.97	dB/m

Electrical Specification Notes:

Insertion Loss does not include the loss of the connectors. Insertion Loss is estimated as 0.1 dB for the straight connector.

Mechanical Specifications

Cable Assembly

Weight 0.124 lbs [56.25 g]

Cable

Cable Type RG58
 Impedance 50 Ohms
 Inner Conductor Type Stranded
 Inner Conductor Material and Plating Copper, Tin
 Dielectric Type PE
 Number of Shields 1
 Shield Layer 1 Tinned Copper Braid
 Jacket Material PVC (NC), Black
 Jacket Diameter 0.195 in [4.95 mm]

One Time Minimum Bend Radius 0.98 in [24.89 mm]
 Repeated Minimum Bend Radius 1.96 in [49.78 mm]

Click the following link (or enter part number in "SEARCH" on website) to obtain additional part information including price, inventory and certifications: [N Male to QMA Male Cable Using RG58 Coax PE3C7692](#)



N Male to QMA Male Cable Using RG58 Coax

RF Cable Assemblies Technical Data Sheet

PE3C7692

Connectors

Description	Connector 1	Connector 2
Type	N Male	QMA Male
Specification	MIL-STD-348	
Impedance	50 Ohms	50 Ohms
Mating Cycles	500	500
Contact Material and Plating	Brass, Gold	Brass, Gold
Contact Plating Specification	50 µin minimum	
Dielectric Type	Teflon	PTFE
Outer Conductor Material and Plating		Phosphor Bronze, Tri-Metal
Body Material and Plating	Brass, Tri-Metal	Brass, Tri-Metal
Coupling Nut Material and Plating	Brass, Tri-Metal	
Hex Size	13/16 Inch	
Torque	9 in-lbs [1.02 Nm]	

Environmental Specifications

Temperature

Operating Range -40 to +80 deg C

Compliance Certifications (see [product page](#) for current document)

Plotted and Other Data

Notes:

Click the following link (or enter part number in "SEARCH" on website) to obtain additional part information including price, inventory and certifications: [N Male to QMA Male Cable Using RG58 Coax PE3C7692](#)



N Male to QMA Male Cable Using RG58 Coax

RF Cable Assemblies Technical Data Sheet

PE3C7692

How to Order

Part Number Configuration:

PE3C7692

- **xx**

uu

Unit of Measure:
cm = Centimeters
<blank> = Inches
Length
Base Number

Example: PE3C7692-12 = 12 inches long cable
PE3C7692-100cm = 100 cm long cable

N Male to QMA Male Cable Using RG58 Coax from Pasternack Enterprises has same day shipment for domestic and International orders. Our RF, microwave and millimeter wave products maintain a 99.4% availability and are part of the broadest selection in the industry.

Click the following link (or enter part number in "SEARCH" on website) to obtain additional part information including price, inventory and certifications: [N Male to QMA Male Cable Using RG58 Coax PE3C7692](https://www.pasternack.com/n-male-to-qma-male-cable-using-rg58-pe3c7692-p.aspx)

URL: <https://www.pasternack.com/n-male-to-qma-male-cable-using-rg58-pe3c7692-p.aspx>

The information contained in this document is accurate to the best of our knowledge and representative of the part described herein. It may be necessary to make modifications to the part and/or the documentation of the part, in order to implement improvements. Pasternack reserves the right to make such changes as required. Unless otherwise stated, all specifications are nominal. Pasternack does not make any representation or warranty regarding the suitability of the part described herein for any particular purpose, and Pasternack does not assume any liability arising out of the use of any part or documentation.

PE3C7692 CAD Drawing

N Male to QMA Male Cable Using RG58 Coax

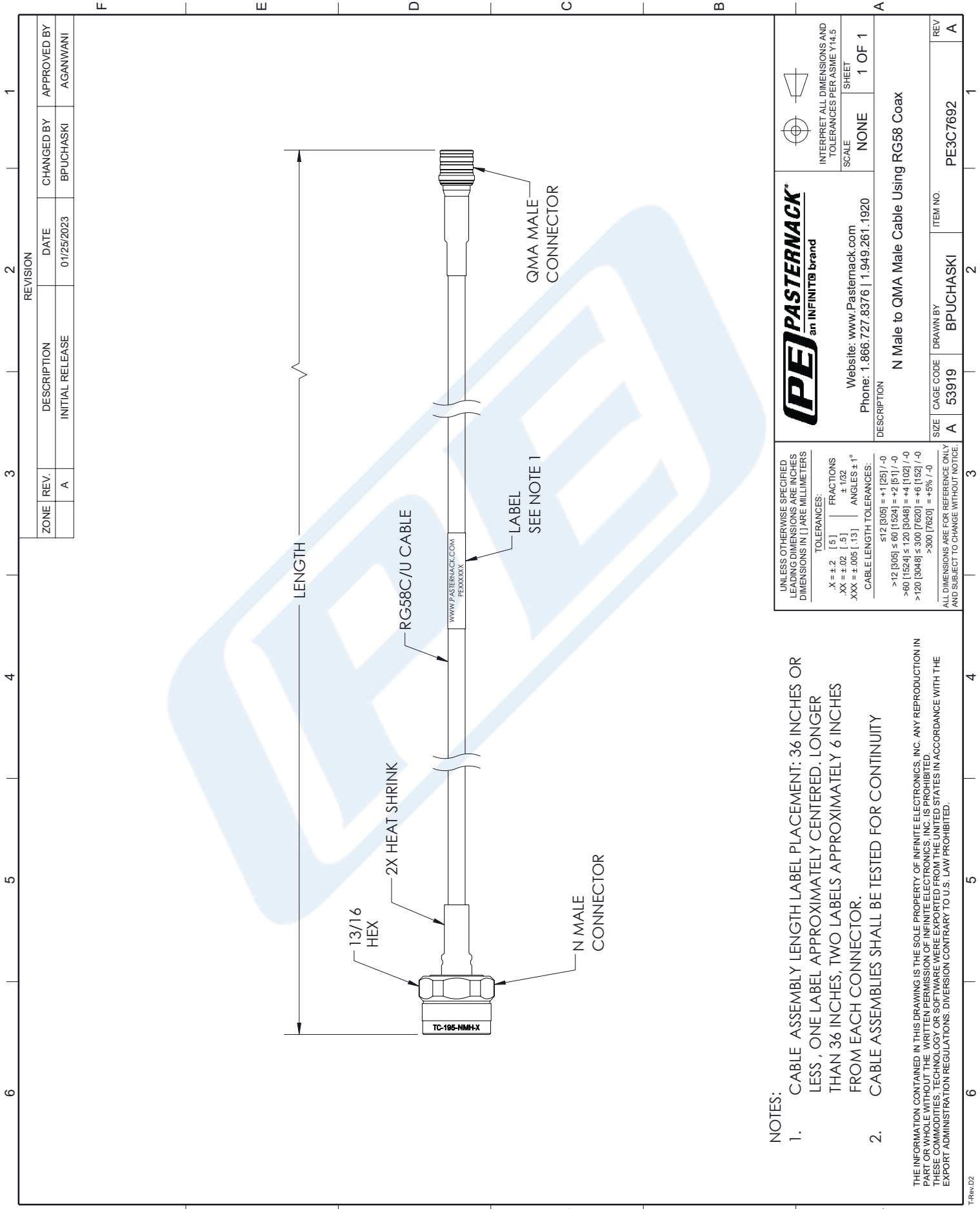

NOTES:

1. CABLE ASSEMBLY LABEL PLACEMENT: 36 INCHES OR LESS, ONE LABEL APPROXIMATELY CENTERED. LONGER THAN 36 INCHES, TWO LABELS APPROXIMATELY 6 INCHES FROM EACH CONNECTOR.
2. CABLE ASSEMBLIES SHALL BE TESTED FOR CONTINUITY

THE INFORMATION CONTAINED IN THIS DRAWING IS THE SOLE PROPERTY OF INFINITE ELECTRONICS, INC. ANY REPRODUCTION IN PART OR WHOLE WITHOUT THE WRITTEN PERMISSION OF INFINITE ELECTRONICS, INC. IS PROHIBITED. THESE COMMODITIES, TECHNOLOGY OR SOFTWARE WERE EXPORTED FROM THE UNITED STATES IN ACCORDANCE WITH THE EXPORT ADMINISTRATION REGULATIONS. DIVERSION CONTRARY TO U.S. LAW PROHIBITED.

<p>PASTERNAK an INFINITIB brand</p>		INTERPRET ALL DIMENSIONS AND TOLERANCES PER ASME Y14.5 SCALE: NONE SHEET: 1 OF 1
	Website: www.Pasternack.com Phone: 1.866.727.8376 1.949.261.1920	
DESCRIPTION N Male to QMA Male Cable Using RG58 Coax		
SIZE: A CAGE CODE: 53919 DRAWN BY: BPUCHASKI ITEM NO.: PE3C7692	REV: A	

UNLESS OTHERWISE SPECIFIED LEADING DIMENSIONS ARE INCHES DIMENSIONS IN [] ARE MILLIMETERS	
TOLERANCES: .X = ±.2 [.5] .XX = ±.02 [.13] .XXX = ±.005 [.13]	FRACTIONS: ± 1/32 ANGLES ± 1°
CABLE LENGTH TOLERANCES: ≤ 12 [305] = +1 [25] / -0 > 12 [305] ≤ 60 [1524] = +2 [51] / -0 > 60 [1524] ≤ 120 [3048] = +4 [102] / -0 > 120 [3048] ≤ 300 [7620] = +6 [152] / -0 > 300 [7620] = +5% / -0	
ALL DIMENSIONS ARE FOR REFERENCE ONLY AND SUBJECT TO CHANGE WITHOUT NOTICE.	