



## SMA Male to SMA Female Bulkhead Cable Using 1/4 inch Superflexible Coax

### RF Cable Assemblies Technical Data Sheet

PE3C7866

#### Configuration

- Connector 1: SMA Male
- Connector 2: SMA Female Bulkhead
- Cable Type: 1/4" Superflexible

#### Features

- Max Frequency 6 GHz
- Low PIM: -150 dBc Max
- Shielding Effectivity > 120 dB
- 82% Phase Velocity
- PE Jacket
- Low PIM and Low Loss
- 100% Tested with PIM Test Results Marked on Cable

#### Applications

- General Purpose
- Laboratory Use
- Distributed Antenna Systems (DAS)
- Low PIM Applications and PIM Testing

#### Description

Pasternack's PE3C7866 SMA male to SMA female bulkhead cable using 1/4 inch superflexible coax is part of our full line of RF components available for same-day shipping. Pasternack's corrugated RF cable assemblies are ideal for applications where durability and high power are needed. This Pasternack SMA to SMA cable assembly has a male to female gender configuration with 50 ohm corrugated 1/4" superflexible coax. The PE3C7866 SMA male to SMA female cable assembly operates to 6 GHz. Our RF cable assembly with SMA bulkhead interface allows designers to create external connections on their product enclosures, and can be used in a variety of other rack mount and panel mount applications.

Custom versions of most RF cable assemblies can be built and shipped same day. Custom cable assembly lengths can be obtained by specifying the desired length on the web site at time of order or by contacting a sales representative. Other available RF cable assembly value added services include connector orientation or clocking, heat shrink booting and custom labeling. RF testing can also be performed to document the electrical performance of your cable assembly.

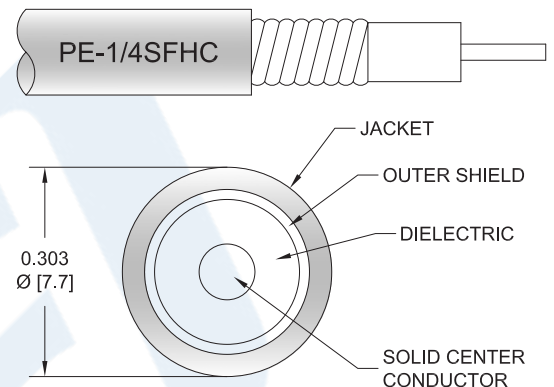

Click the following link (or enter part number in "SEARCH" on website) to obtain additional part information including price, inventory and certifications: [SMA Male to SMA Female Bulkhead Cable Using 1/4 inch Superflexible Coax PE3C7866](#)



## SMA Male to SMA Female Bulkhead Cable Using 1/4 inch Superflexible Coax

### RF Cable Assemblies Technical Data Sheet

PE3C7866

#### Electrical Specifications

Description	Minimum	Typical	Maximum	Units
Frequency Range	DC		6	GHz
VSWR			1.5:1	
Velocity of Propagation		82		%
RF Shielding	120			dB
Passive Intermodulation			-150	dBc
Capacitance		24.4 [80.05]		pF/ft [pF/m]
Inductance		0.059 [0.19]		uH/ft [uH/m]
DC Resistance Inner Conductor		3.2 [10.5]		$\Omega$ /1000ft [ $\Omega$ /Km]
DC Resistance Outer Conductor		2.53 [8.3]		$\Omega$ /1000ft [ $\Omega$ /Km]
Jacket Spark			2,000	Vrms

#### Specifications by Frequency

Description	F1	F2	F3	F4	F5	Units
Frequency	0.1	0.25	0.5	1	3	GHz
Insertion Loss (Typ.)	0.016	0.026	0.039	0.057	0.107	dB/ft
	0.05	0.09	0.13	0.19	0.35	dB/m

#### Electrical Specification Notes:

Insertion Loss does not include the loss of the connectors. Insertion Loss is estimated as 0.2dB connector loss.

#### Mechanical Specifications

##### Cable Assembly

Diameter 0.49 in [12.45 mm]

##### Cable

Cable Type 1/4" Superflexible  
 Impedance 50 Ohms  
 Inner Conductor Type Solid  
 Inner Conductor Material and Plating Copper Clad Aluminum  
 Dielectric Type PE (F)  
 Number of Shields 1  
 Shield Layer 1 Helically Corrugated Copper Tube  
 Jacket Material PE, Black  
 Jacket Diameter 0.303 in [7.7 mm]

Click the following link (or enter part number in "SEARCH" on website) to obtain additional part information including price, inventory and certifications: [SMA Male to SMA Female Bulkhead Cable Using 1/4 inch Superflexible Coax PE3C7866](#)



SMA Male to SMA Female Bulkhead Cable  
Using 1/4 inch Superflexible Coax

RF Cable Assemblies Technical Data Sheet

PE3C7866

One Time Minimum Bend Radius	0.5 in [12.7 mm]
Repeated Minimum Bend Radius	1 in [25.4 mm]
Typical Flex Cycles	20
Tensile Strength	79 lbs [35.83 Kg]

**Connectors**

Description	Connector 1	Connector 2
Type	SMA Male	SMA Female Bulkhead
Specification	SMA	SMA
Impedance	50 Ohms	50 Ohms
Contact Material and Plating	Brass, Silver	
Dielectric Type	PTFE	PTFE
Outer Conductor Material and Plating		Beryllium Copper, Silver
Body Material and Plating	Brass, Tri-Metal	Brass, Tri-Metal
Coupling Nut Material and Plating	Brass, Tri-Metal	

**Environmental Specifications**

**Temperature**

Operating Range	-40 to +85 deg C
-----------------	------------------

**Compliance Certifications** (see [product page](#) for current document)

**Plotted and Other Data**

Notes:

Click the following link (or enter part number in "SEARCH" on website) to obtain additional part information including price, inventory and certifications: [SMA Male to SMA Female Bulkhead Cable Using 1/4 inch Superflexible Coax PE3C7866](#)



## SMA Male to SMA Female Bulkhead Cable Using 1/4 inch Superflexible Coax

### RF Cable Assemblies Technical Data Sheet

PE3C7866

#### How to Order

Part Number Configuration:

**PE3C7866**

- **xx**

**uu**

Unit of Measure:  
cm = Centimeters  
<blank> = Inches  
Length  
Base Number

Example: PE3C7866-12 = 12 inches long cable  
PE3C7866-100cm = 100 cm long cable

SMA Male to SMA Female Bulkhead Cable Using 1/4 inch Superflexible Coax from Pasternack Enterprises has same day shipment for domestic and International orders. Our RF, microwave and millimeter wave products maintain a 99.4% availability and are part of the broadest selection in the industry.

Click the following link (or enter part number in "SEARCH" on website) to obtain additional part information including price, inventory and certifications: [SMA Male to SMA Female Bulkhead Cable Using 1/4 inch Superflexible Coax PE3C7866](#)

URL: <https://www.pasternack.com/sma-male-sma-female-pe-1-4-sfhc-cable-assembly-pe3c7866-p.aspx>

The information contained in this document is accurate to the best of our knowledge and representative of the part described herein. It may be necessary to make modifications to the part and/or the documentation of the part, in order to implement improvements. Pasternack reserves the right to make such changes as required. Unless otherwise stated, all specifications are nominal. Pasternack does not make any representation or warranty regarding the suitability of the part described herein for any particular purpose, and Pasternack does not assume any liability arising out of the use of any part or documentation.

# PE3C7866 CAD Drawing

SMA Male to SMA Female Bulkhead Cable Using 1/4 inch Superflexible Coax

REVISIONS			
REV.	DESCRIPTION	DATE	APPROVED
A	INITIAL RELEASE	1/18/2021	S. ELLIS

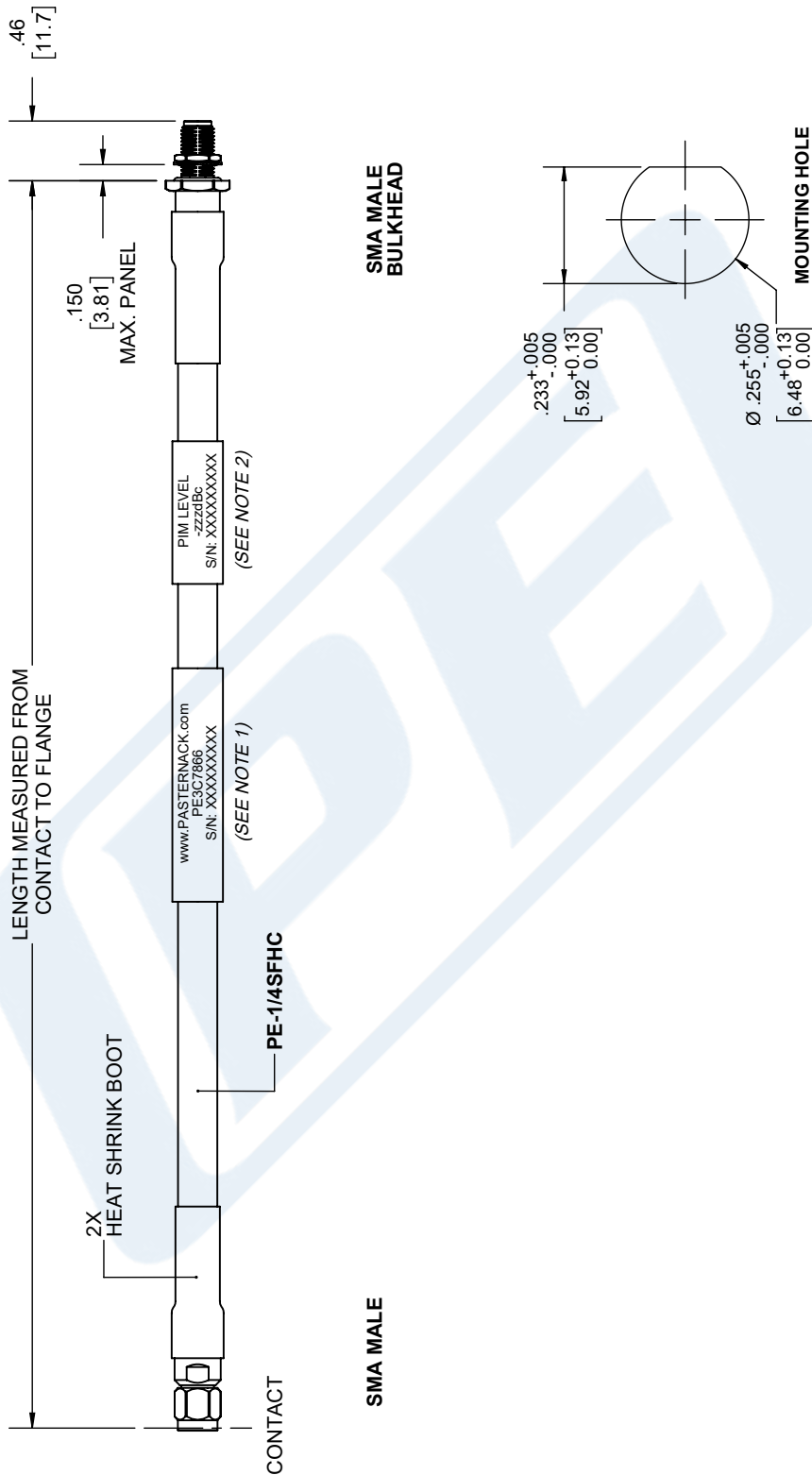

**NOTES:**

1. CABLES 84" AND UNDER HAVE 1 LABEL CENTERED. CABLES OVER 84" HAVE 2 LABELS, ONE AT EACH END 12.0" FROM THE END OF THE CONNECTOR.
2. 6" FROM CABLE END 1 PLACE FOR ALL LENGTHS OF CABLE.

THESE COMMODITIES, TECHNOLOGY OR SOFTWARE WERE EXPORTED FROM THE UNITED STATES IN ACCORDANCE WITH THE EXPORT ADMINISTRATION REGULATIONS. DIVERSION CONTRARY TO U.S. LAW PROHIBITED.

UNLESS OTHERWISE SPECIFIED LEADING DIMENSIONS ARE INCHES DIMENSIONS IN [ ] ARE MILLIMETERS	
TOLERANCES:	FRACTIONS
.X = ±.2 [5.08]	±.1/32
.XX = ±.02 [ .51]	±.1/32
.XXX = ±.005 [ .13]	ANGLES ± 1°
CABLE LENGTH (L), TOLERANCES:	
L ≤ 12 [305]	= +1 [25] / -0
12 [305] < L ≤ 60 [1524]	= +2 [51] / -0
60 [1524] < L ≤ 120 [3048]	= +4 [102] / -0
120 [3048] < L ≤ 300 [7620]	= +6 [152] / -0
300 [7620] < L	= +5% / -0
ALL DIMENSIONS SHOWN ARE FOR REFERENCE ONLY.	

<p>THIRD-ANGLE PROJECTION</p> <p>THE INFORMATION AND DESIGN IN THIS DOCUMENT IS THE PROPERTY OF PASTERNAK CORPORATION ALL RIGHTS RESERVED.</p>	
<p><b>PASTERNAK</b><sup>®</sup> an INFINITE<sup>®</sup> brand</p> <p>Pasternack Enterprises, Inc. P. O. Box 16759, Irvine, CA 92623. Phone: 1.949.261.1920   1.866.727.8376 Fax: 1.949.261.7451 Website: www.pasternack.com E-mail: sales@pasternack.com</p>	
SIZE	ITEM NO.
A	PE3C7866
CAGE CODE	DRAWN BY
53919	K.DANG
SCALE	REV
N/A	A
SHEET 1	OF 1