

## SMA Male to TNC Male Right Angle Cable Using LMR-240 Coax

### RF Cable Assemblies Technical Data Sheet

**PE3C9447**

#### Configuration

- Connector 1: SMA Male
- Connector 2: TNC Male Right Angle
- Cable Type: LMR-240

#### Features

- Max Frequency 2 GHz
- Shielding Effectivity > 90 dB
- 84% Phase Velocity
- Double Shielded
- PE Jacket

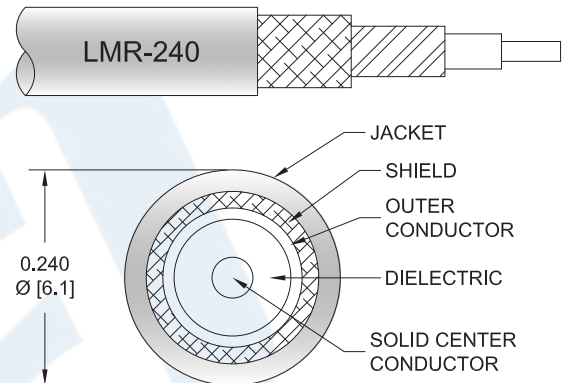

#### Applications

- General Purpose
- Laboratory Use

#### Description

Pasternack's PE3C9447 SMA male to TNC male right angle cable using LMR-240 coax is part of our full line of RF components available for same-day shipping. Pasternack's flexible RF cable assemblies are ideal for applications where tight bends and flexure are required. This Pasternack SMA to TNC cable assembly has a male to male gender configuration with 50 ohm flexible LMR-240 coax. The PE3C9447 SMA male to TNC male cable assembly operates to 2 GHz. The right angle TNC interface on the LMR-240 cable allows for easier connections in tight spaces. The double shielding of this Pasternack cable assembly provides excellent shielding effectiveness of better than 90 dB.

Custom versions of most RF cable assemblies can be built and shipped same day. Custom cable assembly lengths can be obtained by specifying the desired length on the web site at time of order or by contacting a sales representative. Other available RF cable assembly value added services include connector orientation or clocking, heat shrink booting and custom labeling. RF testing can also be performed to document the electrical performance of your cable assembly.

Click the following link (or enter part number in "SEARCH" on website) to obtain additional part information including price, inventory and certifications: [SMA Male to TNC Male Right Angle Cable Using LMR-240 Coax PE3C9447](#)

# SMA Male to TNC Male Right Angle Cable Using LMR-240 Coax

## RF Cable Assemblies Technical Data Sheet

**PE3C9447**

### Electrical Specifications

Description	Minimum	Typical	Maximum	Units
Frequency Range	Error on F1=NULL		Error on F1=NULL	
VSWR			1.4:1	
Velocity of Propagation		84		%
RF Shielding	90			dB
Group Delay		1.21 [3.97]		ns/ft [ns/m]
Capacitance		24.2 [79.4]		pF/ft [pF/m]
Inductance		0.06 [0.2]		uH/ft [uH/m]
DC Resistance Inner Conductor		3.2 [10.5]		Ω/1000ft [Ω/Km]
DC Resistance Outer Conductor		3.89 [12.76]		Ω/1000ft [Ω/Km]
Jacket Spark			5,000	Vrms

### Specifications by Frequency

Description	F1	F2	F3	F4	F5	Units
Frequency	0.05	0.1	0.25	0.5	2	GHz
Insertion Loss (Max.)	1.017	1.0235	1.039087	1.055556	1.115	dB/ft
	3.34	3.36	3.41	3.46	3.66	dB/m
VSWR (Max.)	1.4:1	1.4:1	1.4:1	1.4:1	1.4:1	
Return Loss (Max.)	15.56	15.563	15.563	15.563	15.563	dB

### Mechanical Specifications

#### Cable Assembly

Weight 0.086 lbs [39.01 g]

#### Cable

Cable Type LMR-240  
 Impedance 50 Ohms  
 Inner Conductor Type Solid  
 Inner Conductor Material and Plating Copper  
 Dielectric Type PE (F)  
 Number of Shields 2  
 Shield Layer 1 Aluminum Tape  
 Shield Layer 2 Tinned Copper Braid  
 Jacket Material PE, Black  
 Jacket Diameter 0.24 in [6.1 mm]

Click the following link (or enter part number in "SEARCH" on website) to obtain additional part information including price, inventory and certifications: [SMA Male to TNC Male Right Angle Cable Using LMR-240 Coax PE3C9447](#)

## SMA Male to TNC Male Right Angle Cable Using LMR-240 Coax

### RF Cable Assemblies Technical Data Sheet

**PE3C9447**

One Time Minimum Bend Radius	0.75 in [19.05 mm]
Repeated Minimum Bend Radius	2.5 in [63.5 mm]
Bending Moment	0.25 lbs-ft [0.34 N-m]
Flat Plate Crush	20 lbs/in [0.36 Kg/mm]
Tensile Strength	80 lbs [36.29 Kg]

#### Connectors

Description	Connector 1	Connector 2
Type	SMA Male	TNC Male Right Angle
Specification	MIL-STD-348	
Impedance	50 Ohms	50 Ohms
Contact Material and Plating	Beryllium Copper, Gold	Brass, Gold
Contact Plating Specification	ASTM B488	
Dielectric Type	PTFE	Teflon
Outer Conductor Material and Plating	Brass, Tri-Metal	
Body Material and Plating	Brass, Tri-Metal	Brass, Nickel
Coupling Nut Material and Plating	Brass, Tri-Metal	Brass, Nickel
Hex Size	5/16 Inch	

**Compliance Certifications** (see [product page](#) for current document)

#### Plotted and Other Data

Notes:

Click the following link (or enter part number in "SEARCH" on website) to obtain additional part information including price, inventory and certifications: [SMA Male to TNC Male Right Angle Cable Using LMR-240 Coax PE3C9447](#)

## SMA Male to TNC Male Right Angle Cable Using LMR-240 Coax

### RF Cable Assemblies Technical Data Sheet

**PE3C9447**

#### How to Order

Part Number Configuration:

**PE3C9447**

- **xx**

**uu**

Unit of Measure:

cm = Centimeters

<blank> = Inches

Length

Base Number

Example: PE3C9447-12 = 12 inches long cable  
PE3C9447-100cm = 100 cm long cable

SMA Male to TNC Male Right Angle Cable Using LMR-240 Coax from Pasternack Enterprises has same day shipment for domestic and International orders. Our RF, microwave and millimeter wave products maintain a 99.4% availability and are part of the broadest selection in the industry.

Click the following link (or enter part number in "SEARCH" on website) to obtain additional part information including price, inventory and certifications: [SMA Male to TNC Male Right Angle Cable Using LMR-240 Coax PE3C9447](#)

URL: <https://www.pasternack.com/sma-male-to-tnc-male-cable-using-lmr-240-pe3c9447-p.aspx>

The information contained in this document is accurate to the best of our knowledge and representative of the part described herein. It may be necessary to make modifications to the part and/or the documentation of the part, in order to implement improvements. Pasternack reserves the right to make such changes as required. Unless otherwise stated, all specifications are nominal. Pasternack does not make any representation or warranty regarding the suitability of the part described herein for any particular purpose, and Pasternack does not assume any liability arising out of the use of any part or documentation.

# PE3C9447 CAD Drawing

## SMA Male to TNC Male Right Angle Cable Using LMR-240 Coax

REVISIONS			
REV.	DESCRIPTION	DATE	APPROVED
A	INITIAL RELEASE	10/17/2022	A. GANWANI

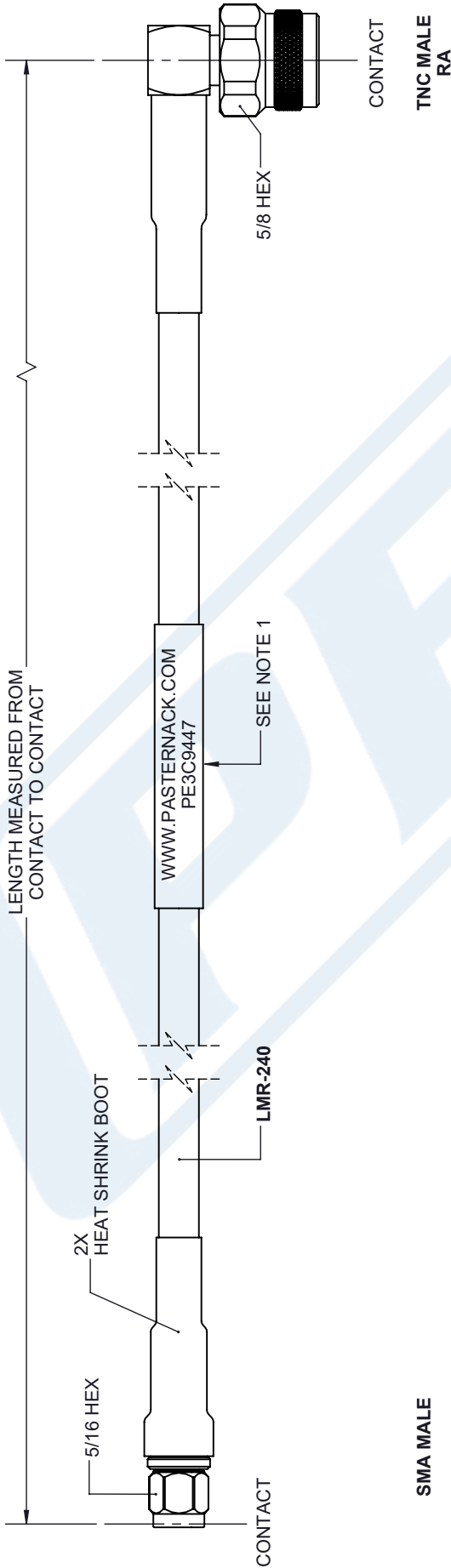

**UNLESS OTHERWISE SPECIFIED LEADING DIMENSIONS ARE INCHES DIMENSIONS IN [ ] ARE MILLIMETERS**

**TOLERANCES:**

.X = ±.2	[.008]	FRACTIONS	± 1/32
.XX = ±.02	[.51]		± 1/32
.XXX = ±.005	[.13]	ANGLES ± 1°	

**CABLE LENGTH (L), TOLERANCES:**

L ≤ 12 [305]	± .1 [25]	/ -0
12 [305] < L ≤ 60 [1524]	± .2 [51]	/ -0
60 [1524] < L ≤ 120 [3048]	± .4 [102]	/ -0
120 [3048] < L ≤ 300 [7620]	± .6 [152]	/ -0
300 [7620] < L	± .5% [ ]	/ -0

ALL DIMENSIONS SHOWN ARE FOR REFERENCE ONLY.

**THIRD-ANGLE PROJECTION**

THE INFORMATION AND DESIGN IN THIS DOCUMENT IS THE PROPERTY OF PASTERNAK CORPORATION ALL RIGHTS RESERVED.

SHEET 1 OF 1

SCALE N/A

**PASTERNAK**  
an INFINITE brand

Pasternack Enterprises, Inc.  
P. O. Box 16759, Irvine, CA 92623.  
Phone: 1.949.261.1920 | 1.866.727.8376  
Fax: 1.949.261.7451  
Website: www.pasternack.com  
E-mail: sales@pasternack.com

SIZE	CAGE CODE	DRAWN BY	ITEM NO.
A	53919	K.DANG	PE3C9447

- NOTES:**
- CABLES 36" AND UNDER HAVE 1 LABEL CENTERED. CABLES OVER 36" HAVE 2 LABELS, ONE AT EACH END 6.0" FROM THE END OF THE CONNECTOR.
- THESE COMMODITIES, TECHNOLOGY OR SOFTWARE WERE EXPORTED FROM THE UNITED STATES IN ACCORDANCE WITH THE EXPORT ADMINISTRATION REGULATIONS. DIVERSION CONTRARY TO U.S. LAW PROHIBITED.