

TNC Male to TNC Female Cable Using LMR-240-UF Coax

RF Cable Assemblies Technical Data Sheet

PE3C9919

Configuration

- Connector 1: TNC Male
- Connector 2: TNC Female
- Cable Type: LMR-240-UF
- Coax Flex Type: Flexible

Features

- Max Frequency 5.8 GHz
- Shielding Effectivity > 90 dB
- 84% Phase Velocity
- Double Shielded
- TPE Jacket
- 500 Mating Cycles

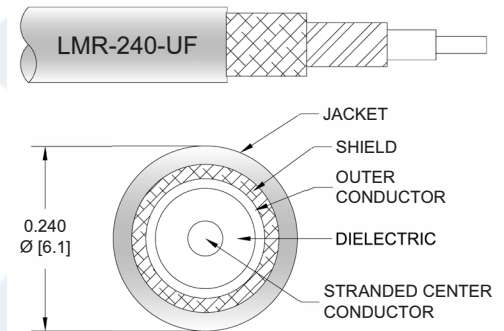

Applications

- General Purpose
- Laboratory Use

Description

Pasternack's PE3C9919 TNC male to TNC female cable using LMR-240-UF coax is part of our full line of RF components available for same-day shipping. Pasternack's flexible RF cable assemblies are ideal for applications where tight bends and flexure are required. This Pasternack TNC to TNC cable assembly has a male to female gender configuration with 50 ohm flexible LMR-240-UF coax. The PE3C9919 TNC male to TNC female cable assembly operates to 5.8 GHz. The double shielding of this Pasternack cable assembly provides excellent shielding effectiveness of better than 90 dB.

Custom versions of most RF cable assemblies can be built and shipped same day. Custom cable assembly lengths can be obtained by specifying the desired length on the web site at time of order or by contacting a sales representative. Other available RF cable assembly value added services include connector orientation or clocking, heat shrink booting and custom labeling. RF testing can also be performed to document the electrical performance of your cable assembly.

Click the following link (or enter part number in "SEARCH" on website) to obtain additional part information including price, inventory and certifications: [TNC Male to TNC Female Cable Using LMR-240-UF Coax PE3C9919](#)

TNC Male to TNC Female Cable Using LMR-240-UF Coax

RF Cable Assemblies Technical Data Sheet

PE3C9919

Electrical Specifications

Description	Minimum	Typical	Maximum	Units
Frequency Range	DC		5.8	GHz
VSWR			1.4:1	
Velocity of Propagation		84		%
RF Shielding	90			dB
Group Delay		1.21 [3.97]		ns/ft [ns/m]
Capacitance		24.2 [79.4]		pF/ft [pF/m]
Inductance		0.06 [0.2]		uH/ft [uH/m]
DC Resistance Inner Conductor		4.28 [14.04]		Ω /1000ft [Ω /Km]
DC Resistance Outer Conductor		3.89 [12.76]		Ω /1000ft [Ω /Km]
Jacket Spark			5,000	Vrms

Specifications by Frequency

Description	F1	F2	F3	F4	F5	Units
Frequency	0.25	0.5	1	2.5	5.8	GHz
Insertion Loss (Max.)	1.046478	1.066111	1.0955	1.155	1.243968	dB/ft
	3.43	3.5	3.59	3.79	4.08	dB/m
VSWR (Max.)	1.4:1	1.4:1	1.4:1	1.4:1	1.4:1	
Return Loss (Max.)	15.56	15.563	15.563	15.563	15.563	dB

Mechanical Specifications

Cable Assembly

Weight 0.151 lbs [68.49 g]

Cable

Cable Type LMR-240-UF
 Impedance 50 Ohms
 Inner Conductor Type Stranded
 Inner Conductor Material and Plating Copper
 Dielectric Type PE (F)
 Number of Shields 2
 Shield Layer 1 Aluminum Tape
 Shield Layer 2 Tinned Copper Braid
 Jacket Material TPE, Black
 Jacket Diameter 0.24 in [6.1 mm]

Click the following link (or enter part number in "SEARCH" on website) to obtain additional part information including price, inventory and certifications: [TNC Male to TNC Female Cable Using LMR-240-UF Coax PE3C9919](#)

TNC Male to TNC Female Cable Using LMR-240-UF Coax

RF Cable Assemblies Technical Data Sheet

PE3C9919

One Time Minimum Bend Radius	0.75 in [19.05 mm]
Repeated Minimum Bend Radius	2.5 in [63.5 mm]
Bending Moment	0.13 lbs-ft [0.18 N-m]
Flat Plate Crush	13 lbs/in [0.23 Kg/mm]
Tensile Strength	80 lbs [36.29 Kg]

Connectors

Description	Connector 1	Connector 2
Type	TNC Male Threaded	TNC Female Threaded
Impedance	50 Ohms	50 Ohms
Mating Cycles	500	500
Contact Material and Plating	Brass, Gold	Brass, Tri-Metal
Contact Plating Specification	50 µinch	80 µin minimum
Dielectric Type	Teflon	PTFE
Body Material and Plating	Brass, Tri-Metal	Brass, Tri-Metal
Body Plating Specification	80 µinch	80 µin minimum
Coupling Nut Material and Plating	Brass, Tri-Metal	
Coupling Nut Plating Specification	80 µinch	
Torque	8 in-lbs [0.9 Nm]	

Environmental Specifications

Temperature

Operating Range -40 to +85 deg C

Compliance Certifications (see [product page](#) for current document)

Plotted and Other Data

Notes:

Click the following link (or enter part number in "SEARCH" on website) to obtain additional part information including price, inventory and certifications: [TNC Male to TNC Female Cable Using LMR-240-UF Coax PE3C9919](#)

TNC Male to TNC Female Cable Using LMR-240-UF Coax

RF Cable Assemblies Technical Data Sheet

PE3C9919

How to Order

Part Number Configuration:

PE3C9919

- **xx**

uu

Unit of Measure:

cm = Centimeters

<blank> = Inches

Length

Base Number

Example: PE3C9919-12 = 12 inches long cable
PE3C9919-100cm = 100 cm long cable

TNC Male to TNC Female Cable Using LMR-240-UF Coax from Pasternack Enterprises has same day shipment for domestic and International orders. Our RF, microwave and millimeter wave products maintain a 99.4% availability and are part of the broadest selection in the industry.

Click the following link (or enter part number in "SEARCH" on website) to obtain additional part information including price, inventory and certifications: [TNC Male to TNC Female Cable Using LMR-240-UF Coax PE3C9919](#)

URL: <https://www.pasternack.com/tnc-male-to-tnc-female-cable-using-lmr-240-uf-pe3c9919-p.aspx>

The information contained in this document is accurate to the best of our knowledge and representative of the part described herein. It may be necessary to make modifications to the part and/or the documentation of the part, in order to implement improvements. Pasternack reserves the right to make such changes as required. Unless otherwise stated, all specifications are nominal. Pasternack does not make any representation or warranty regarding the suitability of the part described herein for any particular purpose, and Pasternack does not assume any liability arising out of the use of any part or documentation.

PE3C9919 CAD Drawing

TNC Male to TNC Female Cable Using LMR-240-UF Coax

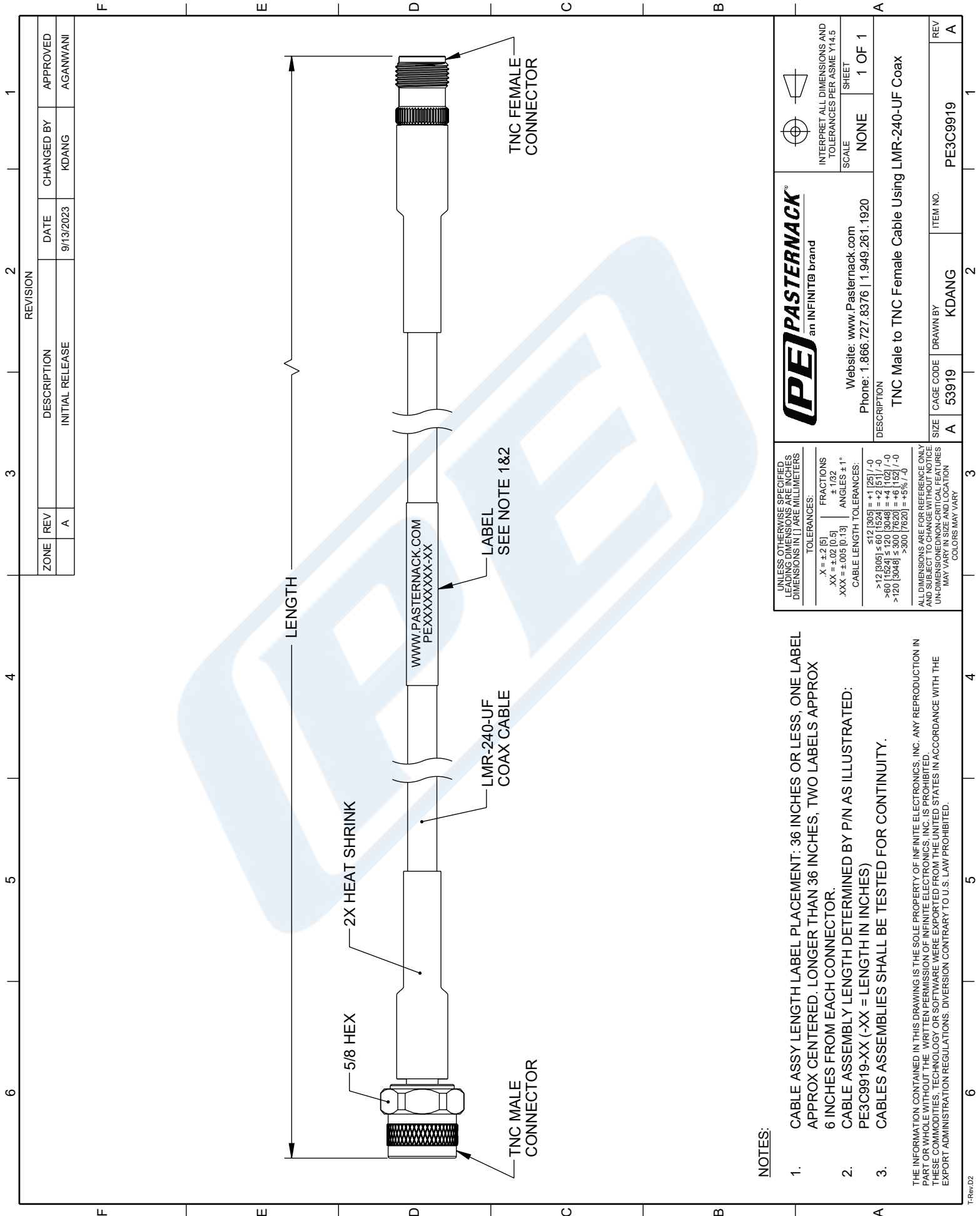

ZONE	REV	DESCRIPTION	DATE	CHANGED BY	APPROVED
	A	INITIAL RELEASE	9/13/2023	KDANG	AGANWANI

UNLESS OTHERWISE SPECIFIED, LEADING DIMENSIONS ARE IN INCHES. DIMENSIONS IN [] ARE MILLIMETERS.

TOLERANCES:

X = ±.2 [5]	FRACTIONS ±.132
.XX = ±.02 [0.5]	ANGLES ± 1°
.XXX = ±.005 [0.13]	CABLE LENGTH TOLERANCES:

$\leq 12 [305]$ = +1 [25] / -0
 $\leq 60 [1524]$ = +2 [51] / -0
 $\leq 120 [3048]$ = +4 [102] / -0
 $\leq 300 [7620]$ = +6 [152] / -0
 >300 [7620] = +5% / -0

ALL DIMENSIONS ARE FOR REFERENCE ONLY AND SUBJECT TO CHANGE WITHOUT NOTICE. UN-DIMENSIONED NON-CRITICAL FEATURES MAY VARY IN SIZE AND LOCATION. COLORS MAY VARY.

PE PASTERNAK
an INFINITI® brand

Website: www.Pasternack.com
 Phone: 1.866.727.8376 | 1.949.261.1920

INTERPRET ALL DIMENSIONS AND TOLERANCES PER ASME Y14.5

SCALE: NONE SHEET: 1 OF 1

DESCRIPTION: TNC Male to TNC Female Cable Using LMR-240-UF Coax

SIZE	CAGE CODE	DRAWN BY	ITEM NO.	REV
A	53919	KDANG	PE3C9919	A

NOTES:

1. CABLE ASSY LENGTH LABEL PLACEMENT: 36 INCHES OR LESS, ONE LABEL APPROX CENTERED. LONGER THAN 36 INCHES, TWO LABELS APPROX 6 INCHES FROM EACH CONNECTOR.
2. CABLE ASSEMBLY LENGTH DETERMINED BY P/N AS ILLUSTRATED: PE3C9919-XX (-XX = LENGTH IN INCHES)
3. CABLES ASSEMBLIES SHALL BE TESTED FOR CONTINUITY.

THE INFORMATION CONTAINED IN THIS DRAWING IS THE SOLE PROPERTY OF INFINITE ELECTRONICS, INC. ANY REPRODUCTION IN PART OR WHOLE WITHOUT THE WRITTEN PERMISSION OF INFINITE ELECTRONICS, INC. IS PROHIBITED. THESE COMMODITIES, TECHNOLOGY OR SOFTWARE WERE EXPORTED FROM THE UNITED STATES IN ACCORDANCE WITH THE EXPORT ADMINISTRATION REGULATIONS. DIVERSION CONTRARY TO U.S. LAW PROHIBITED.