

SMA Female to TNC Male Low Loss Cable Using PE-C400 Coax



PE3W01296

Configuration

- Connector 1: SMA Female
- Connector 2: TNC Male
- Cable Type: PE-C400
- Coax Flex Type: Flexible

Features

- Shielding Effectivity > 90 dB
- 85% Phase Velocity
- Double Shielded
- PE Jacket

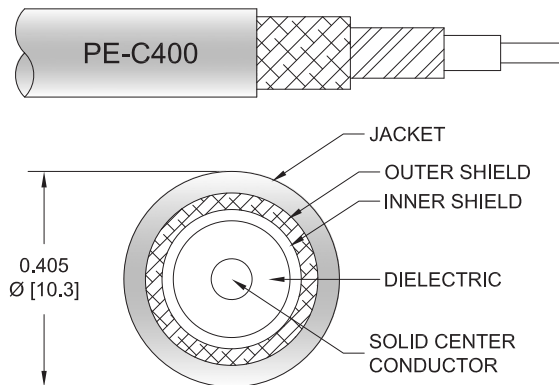

Applications

- General Purpose
- Laboratory Use

Description

Pasternack's PE3W01296 SMA female to TNC male cable using PE-C400 coax is part of our full line of RF components available for same-day shipping. Pasternack's flexible RF cable assemblies are ideal for applications where tight bends and flexure are required. This Pasternack SMA to TNC cable assembly has a female to male gender configuration with 50 ohm flexible PE-C400 coax. The double shielding of this Pasternack cable assembly provides excellent shielding effectiveness of better than 90 dB.

Custom versions of most RF cable assemblies can be built and shipped same day. Custom cable assembly lengths can be obtained by specifying the desired length on the web site at time of order or by contacting a sales representative. Other available RF cable assembly value added services include connector orientation or clocking, heat shrink booting and custom labeling. RF testing can also be performed to document the electrical performance of your cable assembly.

Electrical Specifications

Description	Minimum	Typical	Maximum	Units
Velocity of Propagation		85		%
RF Shielding	90			dB
Capacitance		24 [78.74]		pF/ft [pF/m]
Jacket Spark			8,000	Vrms

Mechanical Specifications

Cable Assembly

Width/Diameter	0.5 in [12.7 mm]
Weight	0.198 lbs [89.81 g]

Cable

Cable Type	PE-C400
Impedance	50 Ohms

SMA Female to TNC Male Low Loss Cable Using PE-C400 Coax



PE3W01296

Inner Conductor Type	Solid
Inner Conductor Material and Plating	Copper Clad Aluminum
Dielectric Type	PE (F)
Number of Shields	2
Shield Layer 1	Aluminum Tape
Shield Layer 2	Tinned Copper Braid
Jacket Material	PE, Black
Jacket Diameter	0.4 in [10.16 mm]
One Time Minimum Bend Radius	1 in [25.4 mm]
Repeated Minimum Bend Radius	4 in [101.6 mm]
Bending Moment	0.5 lbs-ft [0.68 N-m]
Tensile Strength	160 lbs [72.57 Kg]

Connectors

Description	Connector 1	Connector 2
Type	SMA Female	TNC Male
Specification		MIL-STD-348
Impedance	50 Ohms	50 Ohms
Configuration	Straight	Straight
Contact Material and Plating	Brass, Gold	Brass, Silver
Contact Plating Specification		ASTM-B700
Dielectric Type	PTFE	PTFE
Body Material and Plating	Brass, Gold	Brass, Nickel
Body Plating Specification		ASTM-B689
Coupling Nut Material and Plating		Brass, Nickel
Coupling Nut Plating Specification		ASTM-B689

Environmental Specifications

Compliance Certifications (see [product page](#) for current document)

Plotted and Other Data

Notes:

SMA Female to TNC Male Low Loss Cable Using PE-C400 Coax



PE3W01296

Typical Performance Data

How to Order

Part Number Configuration:

PE3W01296

- **xx**

uu

Unit of Measure:

cm = Centimeters

<blank> = Inches

Length

Base Number

Example: PE3W01296-12 = 12 inches long cable
PE3W01296-100cm = 100 cm long cable

SMA Female to TNC Male Low Loss Cable Using PE-C400 Coax from Pasternack Enterprises has same day shipment for domestic and International orders. Our RF, microwave and millimeter wave products maintain a 99.4% availability and are part of the broadest selection in the industry.

Click the following link (or enter part number in "SEARCH" on website) to obtain additional part information including price, inventory and certifications: [SMA Female to TNC Male Low Loss Cable Using PE-C400 Coax PE3W01296](#)

URL: <https://www.pasternack.com/sma-female-to-tnc-male-low-loss-cable-using-pe-c400-pe3w01296-p.aspx>

The information contained within this document is accurate to the best of our knowledge and representative of the part described herein. It may be necessary to make modifications to the part and/or the documentation of the part in order to implement improvements. Pasternack Enterprises reserves the right to make such changes as required. Unless otherwise stated, all specifications are nominal. Pasternack Enterprises does not make any representation or warranty regarding the suitability of the part described herein for any particular purpose, and Pasternack Enterprises does not assume liability arising out of the use of any part or document.

PE3W01296 CAD Drawing

SMA Female to TNC Male Low Loss Cable Using PE-C400 Coax

