



N Male to BNC Male Low Loss Cable Using LMR-400 Coax

TECHNICAL DATA SHEET

PE3W01998

Configuration

- Connector 1: N Male
- Connector 2: BNC Male
- Cable Type: LMR-400
- Coax Flex Type: Flexible

Features

- Shielding Effectivity > 90 dB
- 85% Phase Velocity
- Double Shielded
- PE Jacket

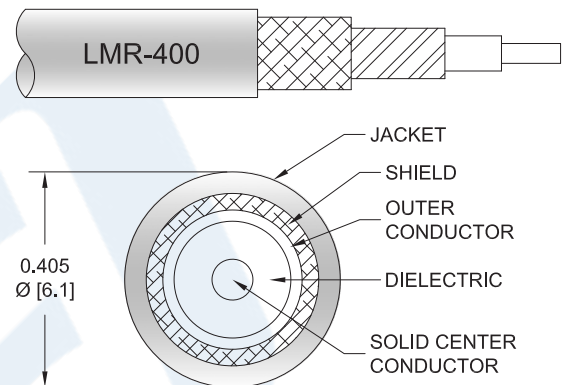

Applications

- General Purpose
- Laboratory Use

Description

Pasternack's PE3W01998 type N male to BNC male cable using LMR-400 coax is part of our full line of RF components available for same-day shipping. Pasternack's flexible RF cable assemblies are ideal for applications where tight bends and flexure are required. This Pasternack type N to BNC cable assembly has a male to male gender configuration with 50 ohm flexible LMR-400 coax. The double shielding of this Pasternack cable assembly provides excellent shielding effectiveness of better than 90 dB.

Custom versions of most RF cable assemblies can be built and shipped same day. Custom cable assembly lengths can be obtained by specifying the desired length on the web site at time of order or by contacting a sales representative. Other available RF cable assembly value added services include connector orientation or clocking, heat shrink booting and custom labeling. RF testing can also be performed to document the electrical performance of your cable assembly.

Click the following link (or enter part number in "SEARCH" on website) to obtain additional part information including price, inventory and certifications: [N Male to BNC Male Low Loss Cable Using LMR-400 Coax PE3W01998](#)



N Male to BNC Male Low Loss Cable Using LMR-400 Coax

TECHNICAL DATA SHEET

PE3W01998

Electrical Specifications

Description	Minimum	Typical	Maximum	Units
Velocity of Propagation		85		%
RF Shielding	90			dB
Group Delay		1.2 [3.94]		ns/ft [ns/m]
Capacitance		23.9 [78.41]		pF/ft [pF/m]
Inductance		0.06 [0.2]		uH/ft [uH/m]
DC Resistance Inner Conductor		1.39 [4.56]		Ω /1000ft [Ω /Km]
DC Resistance Outer Conductor		1.65 [5.41]		Ω /1000ft [Ω /Km]
Jacket Spark			8,000	Vrms

Mechanical Specifications

Cable Assembly

Weight 0.226 lbs [102.51 g]

Cable

Cable Type LMR-400
 Impedance 50 Ohms
 Inner Conductor Type Solid
 Inner Conductor Material and Plating Copper Clad Aluminum
 Dielectric Type PE (F)
 Number of Shields 2
 Shield Layer 1 Aluminum Tape
 Shield Layer 2 Tinned Copper Braid
 Jacket Material PE, Black
 Jacket Diameter 0.405 in [10.29 mm]

One Time Minimum Bend Radius 1 in [25.4 mm]
 Repeated Minimum Bend Radius 4 in [101.6 mm]
 Bending Moment 0.5 lbs-ft [0.68 N-m]
 Flat Plate Crush 40 lbs/in [0.71 Kg/mm]
 Tensile Strength 160 lbs [72.57 Kg]

Click the following link (or enter part number in "SEARCH" on website) to obtain additional part information including price, inventory and certifications: [N Male to BNC Male Low Loss Cable Using LMR-400 Coax PE3W01998](#)



N Male to BNC Male Low Loss Cable Using LMR-400 Coax

TECHNICAL DATA SHEET

PE3W01998

Connectors

Description	Connector 1	Connector 2
Type	N Male Threaded	BNC Male Bayonet
Specification		MIL-STD-348
Impedance	50 Ohms	50 Ohms
Contact Material and Plating	Brass, Gold	Silver
Contact Plating Specification	50 μ in. minimum	QQ-S-365
Dielectric Type	PTFE	PTFE
Body Material and Plating	Brass, Tri-Metal	Brass, Nickel
Body Plating Specification	150 μ in. minimum	QQ-N-290
Coupling Nut Material and Plating	Brass, Tri-Metal	Brass, Nickel
Coupling Nut Plating Specification	150 μ in. minimum	QQ-N-290
Hex Size	13/16 inch	

Compliance Certifications (see [product page](#) for current document)

Plotted and Other Data

Notes:

Click the following link (or enter part number in "SEARCH" on website) to obtain additional part information including price, inventory and certifications: [N Male to BNC Male Low Loss Cable Using LMR-400 Coax PE3W01998](#)



N Male to BNC Male Low Loss Cable Using LMR-400 Coax

TECHNICAL DATA SHEET

PE3W01998

How to Order

Part Number Configuration:

PE3W01998

- **xx**

uu

Unit of Measure:
cm = Centimeters
<blank> = Inches
Length
Base Number

Example: PE3W01998-12 = 12 inches long cable
PE3W01998-100cm = 100 cm long cable

N Male to BNC Male Low Loss Cable Using LMR-400 Coax from Pasternack Enterprises has same day shipment for domestic and International orders. Our RF, microwave and millimeter wave products maintain a 99.4% availability and are part of the broadest selection in the industry.

Click the following link (or enter part number in "SEARCH" on website) to obtain additional part information including price, inventory and certifications: [N Male to BNC Male Low Loss Cable Using LMR-400 Coax PE3W01998](https://www.pasternack.com/n-male-to-bnc-male-low-loss-cable-using-lmr-400-pe3w01998-p.aspx)

URL: <https://www.pasternack.com/n-male-to-bnc-male-low-loss-cable-using-lmr-400-pe3w01998-p.aspx>

The information contained in this document is accurate to the best of our knowledge and representative of the part described herein. It may be necessary to make modifications to the part and/or the documentation of the part, in order to implement improvements. Pasternack reserves the right to make such changes as required. Unless otherwise stated, all specifications are nominal. Pasternack does not make any representation or warranty regarding the suitability of the part described herein for any particular purpose, and Pasternack does not assume any liability arising out of the use of any part or documentation.

PE3W01998 CAD Drawing

N Male to BNC Male Low Loss Cable Using LMR-400 Coax

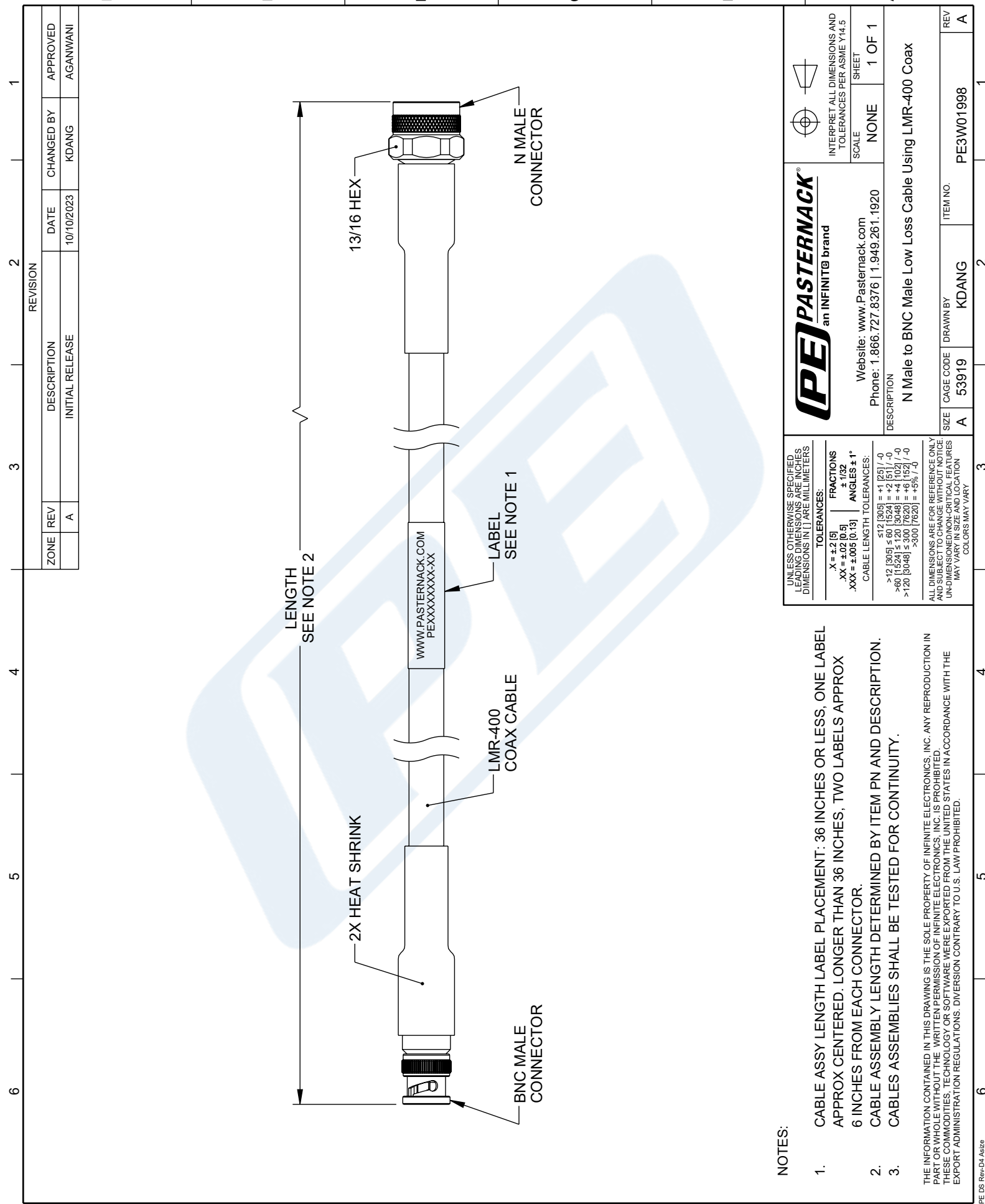

REVISION			
ZONE	REV	DESCRIPTION	CHANGED BY
	A	INITIAL RELEASE	KDANG
			AGANWANI

<p>UNLESS OTHERWISE SPECIFIED LEADING DIMENSIONS ARE IN INCHES DIMENSIONS IN [] ARE MILLIMETERS</p> <p>TOLERANCES:</p> <p>X = ± 2 [5] ± 1/32</p> <p>.XX = ± 02 [0.5] ± 1/32</p> <p>.XXX = ± 005 [0.13] ANGLES ± 1°</p> <p>CABLE LENGTH TOLERANCES:</p> <p>≤ 12 [305] = ± 1 [25] / -0</p> <p>> 12 [305] ≤ 60 [1524] = ± 2 [51] / -0</p> <p>> 60 [1524] ≤ 120 [3048] = ± 4 [102] / -0</p> <p>> 120 [3048] ≤ 300 [7620] = ± 8 [203] / -0</p> <p>> 300 [7620] = ± 9 [228] / -0</p> <p>ALL DIMENSIONS ARE FOR REFERENCE ONLY AND SUBJECT TO CHANGE WITHOUT NOTICE UNDIMENSIONED NON-CRITICAL FEATURES MAY VARY IN SIZE AND LOCATION COLORS MAY VARY</p>	<p>PE PASTERNAK an INFINIT® brand</p> <p>Website: www.Pasternack.com Phone: 1.866.727.8376 1.949.261.1920</p>	<p>INTERPRET ALL DIMENSIONS AND TOLERANCES PER ASME Y14.5</p> <p>SCALE: NONE</p> <p>SHEET: 1 OF 1</p>
	<p>DESCRIPTION</p> <p>N Male to BNC Male Low Loss Cable Using LMR-400 Coax</p>	<p>ITEM NO. PE3W01998</p>
<p>SIZE A</p> <p>CABLE CODE 53919</p> <p>DRAWN BY KDANG</p>	<p>ITEM NO. PE3W01998</p>	<p>REV A</p>

- NOTES:**
- CABLE ASSY LENGTH LABEL PLACEMENT: 36 INCHES OR LESS, ONE LABEL APPROX CENTERED. LONGER THAN 36 INCHES, TWO LABELS APPROX 6 INCHES FROM EACH CONNECTOR.
 - CABLE ASSEMBLY LENGTH DETERMINED BY ITEM PN AND DESCRIPTION.
 - CABLES ASSEMBLIES SHALL BE TESTED FOR CONTINUITY.

THE INFORMATION CONTAINED IN THIS DRAWING IS THE SOLE PROPERTY OF INFINITE ELECTRONICS, INC. ANY REPRODUCTION IN PART OR WHOLE WITHOUT THE WRITTEN PERMISSION OF INFINITE ELECTRONICS, INC. IS PROHIBITED. THESE COMMODITIES, TECHNOLOGY OR SOFTWARE WERE EXPORTED FROM THE UNITED STATES IN ACCORDANCE WITH THE EXPORT ADMINISTRATION REGULATIONS. DIVERSION CONTRARY TO U.S. LAW PROHIBITED.