



SMA Male to N Male Low Loss Cable Using LMR-240 Coax with Times Microwave Components

TECHNICAL DATA SHEET

PE3W02588

Configuration

- Connector 1: SMA Male
- Connector 2: N Male
- Cable Type: LMR-240
- Coax Flex Type: Flexible

Features

- Max Frequency 5.8 GHz
- Double Shielded
- PE Jacket

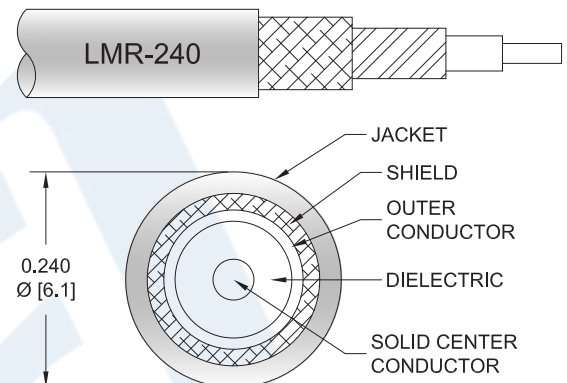

Applications

- General Purpose
- Laboratory Use

Description

Pasternack's PE3W02588 SMA male to type N male cable using LMR-240 coax is part of our full line of RF components available for same-day shipping. Pasternack's flexible RF cable assemblies are ideal for applications where tight bends and flexure are required. This Pasternack SMA to type N cable assembly has a male to male gender configuration with 50 ohm flexible LMR-240 coax. The PE3W02588 SMA male to type N male cable assembly operates to 5.8 GHz. The double shielding of this Pasternack cable assembly provides excellent shielding effectiveness.

Custom versions of most RF cable assemblies can be built and shipped same day. Custom cable assembly lengths can be obtained by specifying the desired length on the web site at time of order or by contacting a sales representative. Other available RF cable assembly value added services include connector orientation or clocking, heat shrink booting and custom labeling. RF testing can also be performed to document the electrical performance of your cable assembly.

Click the following link (or enter part number in "SEARCH" on website) to obtain additional part information including price, inventory and certifications: [SMA Male to N Male Low Loss Cable Using LMR-240 Coax with Times Microwave Components PE3W02588](#)



SMA Male to N Male Low Loss Cable Using LMR-240 Coax with Times Microwave Components

TECHNICAL DATA SHEET

PE3W02588

Electrical Specifications

Description	Minimum	Typical	Maximum	Units
Frequency Range	DC		5.8	GHz
VSWR			1.4:1	

Specifications by Frequency

Part Number	Length	Description	F1	F2	F3	F4	F5	Units	Weight (lbs)
			Frequency	250	500	1000	2500	5800	
PE3W02588	Custom Lengths Available	Insertion Loss (Typ.)	0.04	0.06	0.08	0.12	0.2	dB/ft	
			0.14	0.2	0.27	0.4	0.66	dB/m	
PE3W02588-12	12 inch	Insertion Loss (Typ.)	0.34	0.38	0.43	0.53	0.69	dB	0.14
PE3W02588-24	24 inch	Insertion Loss (Typ.)	0.38	0.44	0.51	0.65	0.89	dB	0.16
PE3W02588-36	36 inch	Insertion Loss (Typ.)	0.42	0.5	0.59	0.77	1.09	dB	0.19
PE3W02588-48	48 inch	Insertion Loss (Typ.)	0.46	0.56	0.67	0.89	1.29	dB	0.21
PE3W02588-60	60 inch	Insertion Loss (Typ.)	0.5	0.62	0.75	1.01	1.49	dB	0.229

The insertion loss data for the base model does not include loss due to the connectors. Each length includes insertion loss due to the connectors.

Loss due to Connector 1:	0.25 dB
Loss due to Connector 2:	$0.1 * \text{SQRT}(\text{FGHz})$ dB
Base Weight:	0.14 pounds
Additional Weight per Inch:	0.00184 pounds

Mechanical Specifications

Cable Assembly

Weight 0.132 lbs [59.87 g]

Click the following link (or enter part number in "SEARCH" on website) to obtain additional part information including price, inventory and certifications: [SMA Male to N Male Low Loss Cable Using LMR-240 Coax with Times Microwave Components PE3W02588](#)



SMA Male to N Male Low Loss Cable Using LMR-240 Coax with Times Microwave Components

TECHNICAL DATA SHEET

PE3W02588

Cable

Cable Type	LMR-240
Impedance	50 Ohms
Inner Conductor Type	Solid
Inner Conductor Material and Plating	Copper
Dielectric Type	PE (F)
Number of Shields	2
Shield Layer 1	Aluminum Tape
Shield Layer 2	Tinned Copper Braid
Jacket Material	PE, Black
Jacket Diameter	0.24 in [6.1 mm]
One Time Minimum Bend Radius	0.75 in [19.05 mm]
Repeated Minimum Bend Radius	2.5 in [63.5 mm]
Bending Moment	0.25 lbs-ft [0.34 N-m]
Flat Plate Crush	20 lbs/in [0.36 Kg/mm]
Tensile Strength	80 lbs [36.29 Kg]

Connectors

Description	Connector 1	Connector 2
Type	SMA Male Threaded	N Male Threaded
Specification	MIL-STD-348	MIL-STD-348
Impedance	50 Ohms	50 Ohms
Contact Material and Plating	Beryllium Copper, Gold	Beryllium Copper, Gold
Contact Plating Specification	ASTM B488	ASTM-B488
Dielectric Type	PTFE	Teflon
Outer Conductor Material and Plating	Brass, Tri-Metal	
Body Material and Plating	Brass, Tri-Metal	Brass, Tri-Metal
Body Plating Specification		QQ-N-290
Coupling Nut Material and Plating	Brass, Tri-Metal	Brass, Tri-Metal
Coupling Nut Plating Specification		QQ-N-290
Hex Size	16-May Inch	

Compliance Certifications (see [product page](#) for current document)

Plotted and Other Data

Notes:

Click the following link (or enter part number in "SEARCH" on website) to obtain additional part information including price, inventory and certifications: [SMA Male to N Male Low Loss Cable Using LMR-240 Coax with Times Microwave Components PE3W02588](#)



SMA Male to N Male Low Loss Cable Using LMR-240 Coax with Times Microwave Components

TECHNICAL DATA SHEET

PE3W02588

How to Order

Part Number Configuration:

PE3W02588

- **xx**

uu

Unit of Measure:
cm = Centimeters
<blank> = Inches
Length
Base Number

Example: PE3W02588-12 = 12 inches long cable
PE3W02588-100cm = 100 cm long cable

SMA Male to N Male Low Loss Cable Using LMR-240 Coax with Times Microwave Components from Pasternack Enterprises has same day shipment for domestic and International orders. Our RF, microwave and millimeter wave products maintain a 99.4% availability and are part of the broadest selection in the industry.

Click the following link (or enter part number in "SEARCH" on website) to obtain additional part information including price, inventory and certifications: [SMA Male to N Male Low Loss Cable Using LMR-240 Coax with Times Microwave Components PE3W02588](https://www.pasternack.com/sma-male-to-n-male-low-loss-cable-using-lmr-240-pe3w02588-p.aspx)

URL: <https://www.pasternack.com/sma-male-to-n-male-low-loss-cable-using-lmr-240-pe3w02588-p.aspx>

The information contained in this document is accurate to the best of our knowledge and representative of the part described herein. It may be necessary to make modifications to the part and/or the documentation of the part, in order to implement improvements. Pasternack reserves the right to make such changes as required. Unless otherwise stated, all specifications are nominal. Pasternack does not make any representation or warranty regarding the suitability of the part described herein for any particular purpose, and Pasternack does not assume any liability arising out of the use of any part or documentation.

