



N Male Right Angle to N Male Right Angle Low Loss Cable Using LMR-600 Coax with Times Microwave Components

TECHNICAL DATA SHEET

PE3W03668

Configuration

- Connector 1: N Male Right Angle
- Connector 2: N Male Right Angle
- Cable Type: LMR-600
- Coax Flex Type: Flexible

Features

- Max Frequency 6 GHz
- Shielding Effectivity > 90 dB
- 87% Phase Velocity
- Double Shielded
- PE Jacket

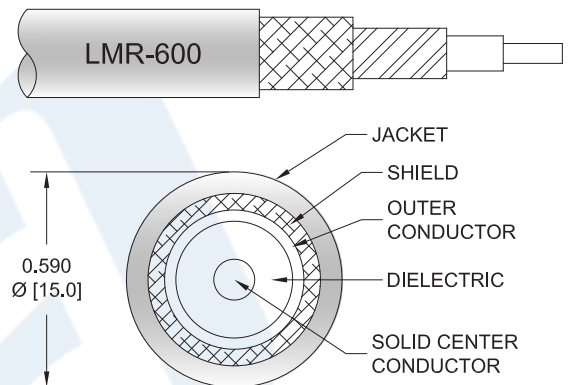

Applications

- General Purpose
- Laboratory Use

Description

Pasternack's PE3W03668 type N male right angle to type N male right angle cable using LMR-600 coax is part of our full line of RF components available for same-day shipping. Pasternack's flexible RF cable assemblies are ideal for applications where tight bends and flexure are required. This Pasternack type N to type N cable assembly has a male to male gender configuration with 50 ohm flexible LMR-600 coax. The PE3W03668 type N male to type N male cable assembly operates to 6 GHz. The right angle type N interfaces on the LMR-600 cable allow for easier connections in tight spaces. The double shielding of this Pasternack cable assembly provides excellent shielding effectiveness of better than 90 dB.

Custom versions of most RF cable assemblies can be built and shipped same day. Custom cable assembly lengths can be obtained by specifying the desired length on the web site at time of order or by contacting a sales representative. Other available RF cable assembly value added services include connector orientation or clocking, heat shrink booting and custom labeling. RF testing can also be performed to document the electrical performance of your cable assembly.

Click the following link (or enter part number in "SEARCH" on website) to obtain additional part information including price, inventory and certifications: [N Male Right Angle to N Male Right Angle Low Loss Cable Using LMR-600 Coax with Times Microwave Components PE3W03668](#)



N Male Right Angle to N Male Right Angle Low Loss Cable Using LMR-600 Coax with Times Microwave Components

TECHNICAL DATA SHEET

PE3W03668

Electrical Specifications

Description	Minimum	Typical	Maximum	Units
Frequency Range	DC		6	GHz
VSWR			1.4:1	
Velocity of Propagation		87		%
RF Shielding	90			dB
Group Delay		1.17 [3.84]		ns/ft [ns/m]
Capacitance		23.4 [76.77]		pF/ft [pF/m]
Inductance		0.058 [0.19]		uH/ft [uH/m]
DC Resistance Inner Conductor		0.53 [1.74]		Ω/1000ft [Ω/Km]
DC Resistance Outer Conductor		1.2 [3.94]		Ω/1000ft [Ω/Km]
Jacket Spark			8,000	Vrms

Specifications by Frequency

Part Number	Length	Description	F1	F2	F3	F4	F5	Units	Weight (lbs)
		Frequency	250	500	1000	2500	6000	MHz	
PE3W03668	Custom Lengths Available	Insertion Loss (Typ.)	0.01	0.02	0.03	0.04	0.07	dB/ft	
			0.04	0.06	0.09	0.15	0.24	dB/m	
PE3W03668-24	24 inch	Insertion Loss (Typ.)	0.13	0.18	0.26	0.41	0.64	dB	0.761
PE3W03668-36	36 inch	Insertion Loss (Typ.)	0.14	0.2	0.28	0.45	0.71	dB	0.898
PE3W03668-48	48 inch	Insertion Loss (Typ.)	0.15	0.21	0.31	0.5	0.79	dB	1.035
PE3W03668-120	120 inch	Insertion Loss (Typ.)	0.22	0.32	0.46	0.76	1.22	dB	1.857
PE3W03668-180	180 inch	Insertion Loss (Typ.)	0.28	0.4	0.59	0.98	1.59	dB	2.542

The insertion loss data for the base model does not include loss due to the connectors. Each length includes insertion loss due to the connectors.

Loss due to Connector 1: $0.1 * \text{SQRT}(\text{FGHz})$ dB
 Loss due to Connector 2: $0.1 * \text{SQRT}(\text{FGHz})$ dB
 Base Weight: 0.623 pounds
 Additional Weight per Inch: 0.01142 pounds

Mechanical Specifications

Cable Assembly

Weight 0.623 lbs [282.59 g]

Click the following link (or enter part number in "SEARCH" on website) to obtain additional part information including price, inventory and certifications: [N Male Right Angle to N Male Right Angle Low Loss Cable Using LMR-600 Coax with Times Microwave Components PE3W03668](#)



N Male Right Angle to N Male Right Angle Low Loss Cable Using LMR-600 Coax with Times Microwave Components

TECHNICAL DATA SHEET

PE3W03668

Cable

Cable Type	LMR-600
Impedance	50 Ohms
Inner Conductor Type	Solid
Inner Conductor Material and Plating	Copper Clad Aluminum
Dielectric Type	PE (F)
Number of Shields	2
Shield Layer 1	Aluminum Tape
Shield Layer 2	Tinned Copper Braid
Jacket Material	PE, Black
Jacket Diameter	0.59 in [14.99 mm]
One Time Minimum Bend Radius	1.5 in [38.1 mm]
Repeated Minimum Bend Radius	6 in [152.4 mm]
Bending Moment	2.75 lbs-ft [3.73 N-m]
Flat Plate Crush	60 lbs/in [1.07 Kg/mm]
Tensile Strength	350 lbs [158.76 Kg]

Connectors

Description	Connector 1	Connector 2
Type	N Male Right Angle Threaded	N Male Right Angle Threaded
Impedance	50 Ohms	50 Ohms
Contact Material and Plating	Beryllium Copper, Gold	Beryllium Copper, Gold
Contact Plating Specification	1.27µm minimum	1.27µm minimum
Dielectric Type	PTFE	PTFE
Body Material and Plating	Brass, Tri-Metal	Brass, Tri-Metal
Body Plating Specification	2µm minimum	2µm minimum
Coupling Nut Material and Plating	Brass, Tri-Metal	Brass, Tri-Metal
Coupling Nut Plating Specification	2µm minimum	2µm minimum
Hex Size	20.57 mm	20.57 mm
Torque	44 in-lbs [4.97 Nm]	44 in-lbs [4.97 Nm]

Environmental Specifications

Temperature

Operating Range -40 to +85 deg C

Compliance Certifications (see [product page](#) for current document)

Plotted and Other Data

Notes:

Click the following link (or enter part number in "SEARCH" on website) to obtain additional part information including price, inventory and certifications: [N Male Right Angle to N Male Right Angle Low Loss Cable Using LMR-600 Coax with Times Microwave Components PE3W03668](#)



N Male Right Angle to N Male Right Angle Low Loss Cable Using LMR-600 Coax with Times Microwave Components

TECHNICAL DATA SHEET

PE3W03668

How to Order

Part Number Configuration:

PE3W03668

- **xx**

uu

Unit of Measure:

cm = Centimeters

<blank> = Inches

Length

Base Number

Example: PE3W03668-12 = 12 inches long cable
PE3W03668-100cm = 100 cm long cable

N Male Right Angle to N Male Right Angle Low Loss Cable Using LMR-600 Coax with Times Microwave Components from Pasternack Enterprises has same day shipment for domestic and International orders. Our RF, microwave and millimeter wave products maintain a 99.4% availability and are part of the broadest selection in the industry.

Click the following link (or enter part number in "SEARCH" on website) to obtain additional part information including price, inventory and certifications: [N Male Right Angle to N Male Right Angle Low Loss Cable Using LMR-600 Coax with Times Microwave Components PE3W03668](#)

URL: <https://www.pasternack.com/n-male-right-angle-to-n-male-low-loss-cable-using-lmr-600-pe3w03668-p.aspx>

The information contained in this document is accurate to the best of our knowledge and representative of the part described herein. It may be necessary to make modifications to the part and/or the documentation of the part, in order to implement improvements. Pasternack reserves the right to make such changes as required. Unless otherwise stated, all specifications are nominal. Pasternack does not make any representation or warranty regarding the suitability of the part described herein for any particular purpose, and Pasternack does not assume any liability arising out of the use of any part or documentation.

PE3W03668 CAD Drawing

N Male Right Angle to N Male Right Angle Low Loss Cable Using LMR-600 Coax with Times Microwave Components

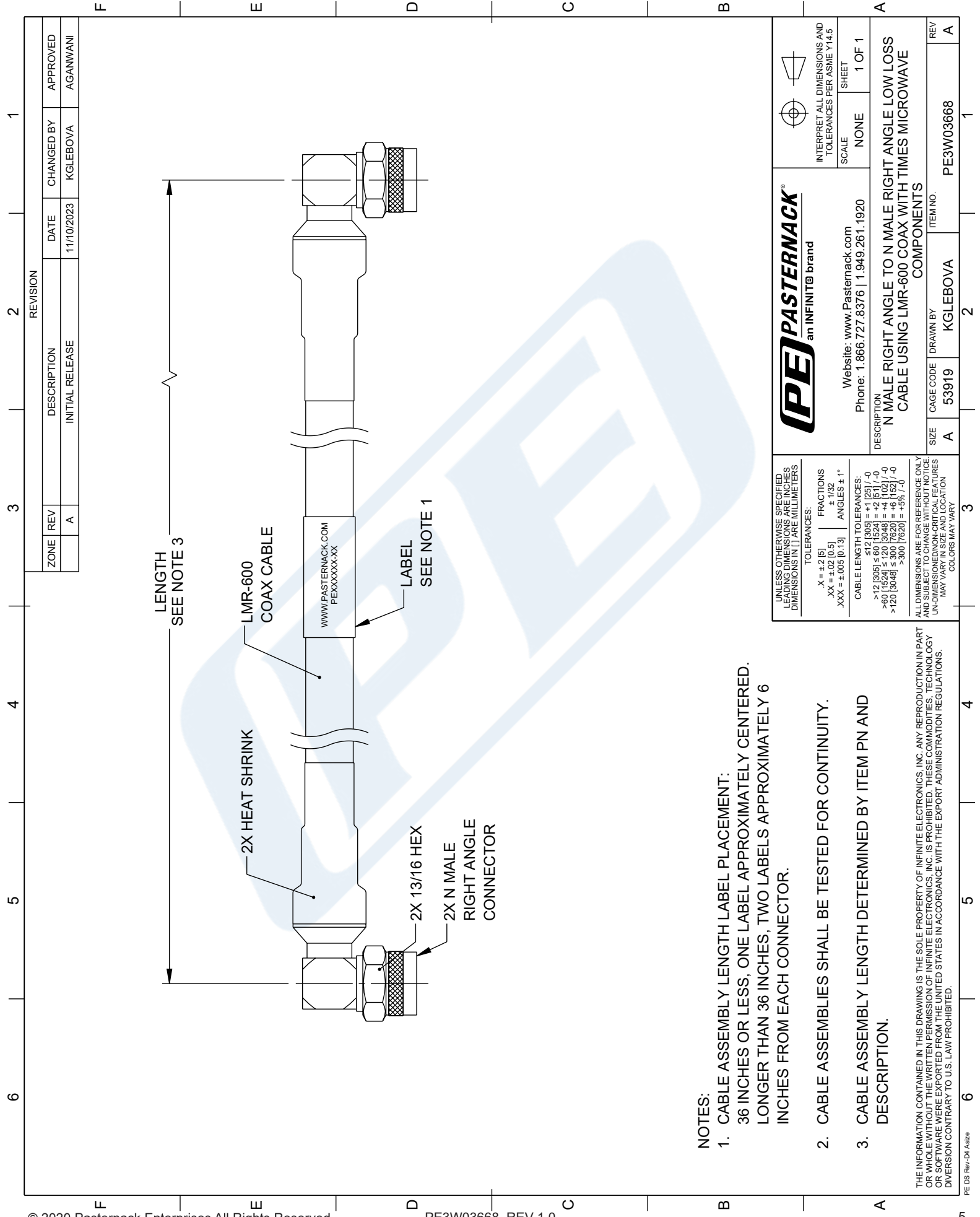

LENGTH
SEE NOTE 3

2X HEAT SHRINK

LMR-600
COAX CABLE

WWW.PASTERNAK.COM
PEXXXXXX-XX

LABEL
SEE NOTE 1

2X 13/16 HEX

2X N MALE
RIGHT ANGLE
CONNECTOR

NOTES:

1. CABLE ASSEMBLY LENGTH LABEL PLACEMENT:
36 INCHES OR LESS, ONE LABEL APPROXIMATELY CENTERED.
LONGER THAN 36 INCHES, TWO LABELS APPROXIMATELY 6
INCHES FROM EACH CONNECTOR.
2. CABLE ASSEMBLIES SHALL BE TESTED FOR CONTINUITY.
3. CABLE ASSEMBLY LENGTH DETERMINED BY ITEM PN AND
DESCRIPTION.

THE INFORMATION CONTAINED IN THIS DRAWING IS THE SOLE PROPERTY OF INFINITE ELECTRONICS, INC. ANY REPRODUCTION IN PART OR WHOLE WITHOUT THE WRITTEN PERMISSION OF INFINITE ELECTRONICS, INC. IS PROHIBITED. THESE COMMODITIES, TECHNOLOGY OR SOFTWARE WERE EXPORTED FROM THE UNITED STATES IN ACCORDANCE WITH THE EXPORT ADMINISTRATION REGULATIONS. DIVERSION CONTRARY TO U.S. LAW PROHIBITED.

REVISION			
ZONE	REV	DESCRIPTION	DATE
	A	INITIAL RELEASE	11/10/2023
		CHANGED BY	AGANWANI
		APPROVED	AGANWANI



Website: www.Pasternack.com
Phone: 1.866.727.8376 | 1.949.261.1920

INTERPRET ALL DIMENSIONS AND TOLERANCES PER ASME Y14.5
SCALE NONE
SHEET 1 OF 1

DESCRIPTION
N MALE RIGHT ANGLE TO N MALE RIGHT ANGLE LOW LOSS
CABLE USING LMR-600 COAX WITH TIMES MICROWAVE
COMPONENTS

SIZE	CAGE CODE	DRAWN BY	ITEM NO.	REV
A	53919	KGLEBOVA	PE3W03668	A

UNLESS OTHERWISE SPECIFIED
LENGTH DIMENSIONS ARE IN INCHES
DIMENSIONS IN [] ARE MILLIMETERS

TOLERANCES:
 .X = ±.2 [5]
 .XX = ±.02 [0.5]
 .XXX = ±.005 [0.13]

FRACTIONS
 ± 1/32
 ANGLES ± 1°

CABLE LENGTH TOLERANCES:
 >12 [305] ≤ 617 [1567] = ±.25 / -0
 >60 [1524] ≤ 120 [3048] = ±4 [102] / -0
 >120 [3048] ≤ 300 [7620] = ±6 [152] / -0
 >300 [7620] = ±5% / -0

ALL DIMENSIONS ARE FOR REFERENCE ONLY
UNLESS OTHERWISE NOTED
UNDIMENSIONED CRITICAL FEATURES
MAY VARY IN SIZE AND LOCATION
COLORS MAY VARY