



N Female to UHF Male Low Loss Cable Using LMR-195 Coax with HeatShrink

RF Cable Assemblies Technical Data Sheet

PE3W06169/HS

Configuration

- Connector 1: N Female
- Connector 2: UHF Male
- Cable Type: LMR-195

Features

- Shielding Effectivity > 90 dB
- 80% Phase Velocity
- Double Shielded
- PE Jacket

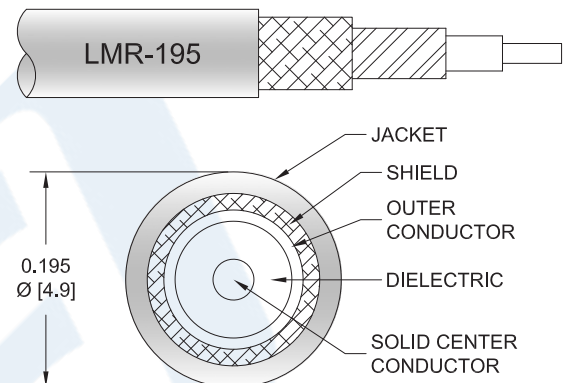

Applications

- General Purpose
- Laboratory Use

Description

Pasternack's PE3W06169/HS type N female to UHF male cable using LMR-195 coax is part of our full line of RF components available for same-day shipping. Pasternack's flexible RF cable assemblies are ideal for applications where tight bends and flexure are required. This Pasternack type N to UHF cable assembly has a female to male gender configuration with 50 ohm flexible LMR-195 coax. The double shielding of this Pasternack cable assembly provides excellent shielding effectiveness of better than 90 dB.

Custom versions of most RF cable assemblies can be built and shipped same day. Custom cable assembly lengths can be obtained by specifying the desired length on the web site at time of order or by contacting a sales representative. Other available RF cable assembly value added services include connector orientation or clocking, heat shrink booting and custom labeling. RF testing can also be performed to document the electrical performance of your cable assembly.

Electrical Specifications

Description	Minimum	Typical	Maximum	Units
Velocity of Propagation		80		%
RF Shielding	90			dB
Group Delay		1.27 [4.17]		ns/ft [ns/m]
Capacitance		25.4 [83.33]		pF/ft [pF/m]
Inductance		0.064 [0.21]		uH/ft [uH/m]
DC Resistance Inner Conductor		7.6 [24.93]		Ω/1000ft [Ω/Km]
DC Resistance Outer Conductor		4.9 [16.08]		Ω/1000ft [Ω/Km]
Jacket Spark			3,000	Vrms

Click the following link (or enter part number in "SEARCH" on website) to obtain additional part information including price, inventory and certifications: [N Female to UHF Male Low Loss Cable Using LMR-195 Coax with HeatShrink PE3W06169/HS](#)



N Female to UHF Male Low Loss Cable Using LMR-195 Coax with HeatShrink

RF Cable Assemblies Technical Data Sheet

PE3W06169/HS

Mechanical Specifications

Cable Assembly

Weight 0.117 lbs [53.07 g]

Cable

Cable Type LMR-195
 Impedance 50 Ohms
 Inner Conductor Type Solid
 Inner Conductor Material and Plating Copper
 Dielectric Type PE (F)
 Number of Shields 2
 Shield Layer 1 Aluminum Tape
 Shield Layer 2 Tinned Copper Braid
 Jacket Material PE, Black
 Jacket Diameter 0.195 in [4.95 mm]

One Time Minimum Bend Radius 0.5 in [12.7 mm]
 Repeated Minimum Bend Radius 2 in [50.8 mm]
 Bending Moment 0.2 lbs-ft [0.27 N-m]
 Flat Plate Crush 15 lbs/in [0.27 Kg/mm]
 Tensile Strength 40 lbs [18.14 Kg]

Connectors

Description	Connector 1	Connector 2
Type	N Female	UHF Male
Impedance	50 Ohms	50 Ohms
Contact Material and Plating		Brass, Gold
Contact Plating Specification		30 µin minimum
Dielectric Type		PTFE
Body Material and Plating	Brass, Nickel	Brass, Nickel
Body Plating Specification		100 µin minimum
Coupling Nut Material and Plating		Brass, Nickel
Coupling Nut Plating Specification		100 µin minimum

Compliance Certifications (see [product page](#) for current document)

Plotted and Other Data

Notes:

Click the following link (or enter part number in "SEARCH" on website) to obtain additional part information including price, inventory and certifications: [N Female to UHF Male Low Loss Cable Using LMR-195 Coax with HeatShrink PE3W06169/HS](#)



N Female to UHF Male Low Loss Cable Using LMR-195 Coax with HeatShrink

RF Cable Assemblies Technical Data Sheet

PE3W06169/HS

How to Order

Part Number Configuration:

PE3W06169/HS - xx uu

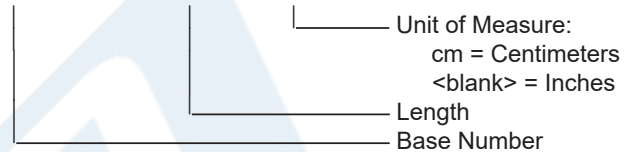

Example: PE3W06169/HS-12 = 12 inches long cable
PE3W06169/HS-100cm = 100 cm long cable

N Female to UHF Male Low Loss Cable Using LMR-195 Coax with HeatShrink from Pasternack Enterprises has same day shipment for domestic and International orders. Our RF, microwave and millimeter wave products maintain a 99.4% availability and are part of the broadest selection in the industry.

Click the following link (or enter part number in "SEARCH" on website) to obtain additional part information including price, inventory and certifications: [N Female to UHF Male Low Loss Cable Using LMR-195 Coax with HeatShrink PE3W06169/HS](#)

URL: <https://www.pasternack.com/n-female-to-uhf-male-low-loss-cable-using-lmr-195-with-heatshrink-pe3w06169-hs-p.aspx>

The information contained in this document is accurate to the best of our knowledge and representative of the part described herein. It may be necessary to make modifications to the part and/or the documentation of the part, in order to implement improvements. Pasternack reserves the right to make such changes as required. Unless otherwise stated, all specifications are nominal. Pasternack does not make any representation or warranty regarding the suitability of the part described herein for any particular purpose, and Pasternack does not assume any liability arising out of the use of any part or documentation.

PE3W06169/HS CAD Drawing

N Female to UHF Male Low Loss Cable Using LMR-195 Coax with HeatShrink

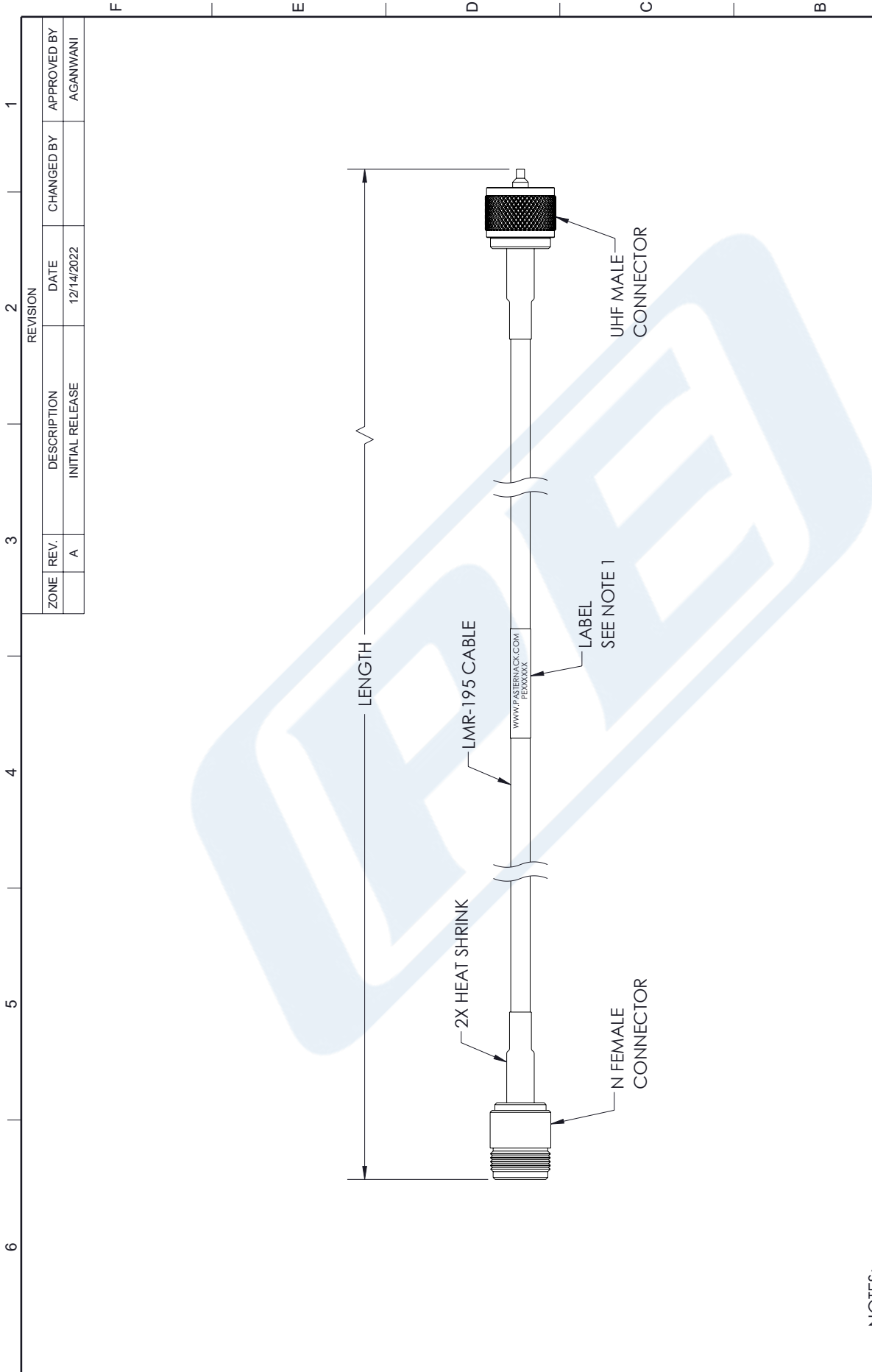

NOTES:

1. CABLE ASSEMBLY LENGTH LABEL PLACEMENT: 36 INCHES OR LESS, ONE LABEL APPROXIMATELY CENTERED. LONGER THAN 36 INCHES, TWO LABELS APPROXIMATELY 6 INCHES FROM EACH CONNECTOR.
2. CABLE ASSEMBLIES SHALL BE TESTED FOR CONTINUITY

THE INFORMATION CONTAINED IN THIS DRAWING IS THE SOLE PROPERTY OF INFINITE ELECTRONICS, INC. ANY REPRODUCTION IN PART OR WHOLE WITHOUT THE WRITTEN PERMISSION OF INFINITE ELECTRONICS, INC. IS PROHIBITED. THESE COMMODITIES, TECHNOLOGY OR SOFTWARE WERE EXPORTED FROM THE UNITED STATES IN ACCORDANCE WITH THE EXPORT ADMINISTRATION REGULATIONS. DIVERSION CONTRARY TO U.S. LAW PROHIBITED.

UNLESS OTHERWISE SPECIFIED LEADING DIMENSIONS ARE INCHES DIMENSIONS IN [] ARE MILLIMETERS	
TOLERANCES:	
.X = ±.2 [.5]	FRACTIONS ± 1/32
.XX = ±.02 [.1]	ANGLES ± 1°
.XXX = ±.005 [.13]	CABLE LENGTH TOLERANCES:
	>12 [305] = +1 [25] / -0
	>12 [305] ≤ 60 [1524] = +2 [51] / -0
	>60 [1524] ≤ 120 [3048] = +4 [102] / -0
	>120 [3048] ≤ 300 [7620] = +6 [152] / -0
	>300 [7620] = +5% / -0
ALL DIMENSIONS ARE FOR REFERENCE ONLY AND SUBJECT TO CHANGE WITHOUT NOTICE.	

PE PASTERNAK an INFINITO brand	
Website: www.Pasternack.com Phone: 1.866.727.8376 1.949.261.1920	
DESCRIPTION N Female to UHF Male Low Loss Cable Using LMR-195 Coax with HeatShrink	
SCALE	NONE
SHEET	1 OF 1
INTERPRET ALL DIMENSIONS AND TOLERANCES PER ASME Y14.5	
SIZE	A
CAGE CODE	53919
DRAWN BY	BPUCHASKI
ITEM NO.	PE3W06169/HS
REV	A