



SMA Male Right Angle to SMA Male Cable Using PE-P195 Coax

TECHNICAL DATA SHEET

PE3W08771

Configuration

- Connector 1: SMA Male Right Angle
- Connector 2: SMA Male
- Cable Type: PE-P195
- Coax Flex Type: Flexible

Features

- Max Frequency 12.4 GHz
- 70% Phase Velocity
- Triple Shielded
- FEP Jacket

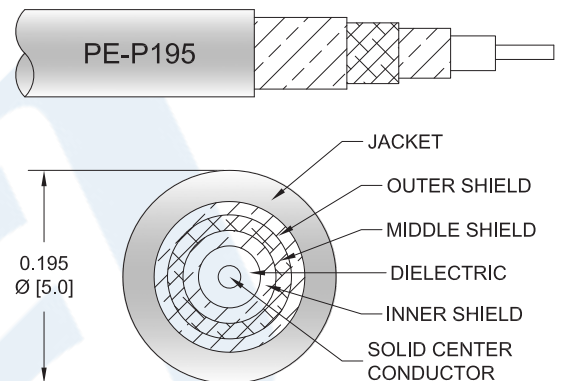

Applications

- General Purpose
- Laboratory Use

Description

Pasternack's PE3W08771 SMA male right angle to SMA male cable using PE-P195 coax is part of our full line of RF components available for same-day shipping. Pasternack's flexible RF cable assemblies are ideal for applications where tight bends and flexure are required. This Pasternack SMA to SMA cable assembly has a male to male gender configuration with 50 ohm flexible PE-P195 coax. The PE3W08771 SMA male to SMA male cable assembly operates to 12.4 GHz. The right angle SMA interface on the PE-P195 cable allows for easier connections in tight spaces. The triple shielding of this Pasternack cable assembly provides excellent shielding effectiveness.

Custom versions of most RF cable assemblies can be built and shipped same day. Custom cable assembly lengths can be obtained by specifying the desired length on the web site at time of order or by contacting a sales representative. Other available RF cable assembly value added services include connector orientation or clocking, heat shrink booting and custom labeling. RF testing can also be performed to document the electrical performance of your cable assembly.

Click the following link (or enter part number in "SEARCH" on website) to obtain additional part information including price, inventory and certifications: [SMA Male Right Angle to SMA Male Cable Using PE-P195 Coax PE3W08771](#)



SMA Male Right Angle to SMA Male Cable Using PE-P195 Coax

TECHNICAL DATA SHEET

PE3W08771

Electrical Specifications

Description	Minimum	Typical	Maximum	Units
Frequency Range	DC		12.4	GHz
VSWR			1.4:1	
Velocity of Propagation		70		%
Capacitance		29 [95.14]		pF/ft [pF/m]

Specifications by Frequency

Part Number	Length	Description	F1	F2	F3	F4	F5	Units	Weight (lbs)
			Frequency						
PE3W08771	Custom Lengths Available	Insertion Loss (Typ.)	0.09	0.13	0.196	0.315	0.512	dB/ft	
			0.29	0.42	0.65	1.04	1.68	dB/m	
PE3W08771-12	12 inch	Insertion Loss (Typ.)	0.39	0.43	0.5	0.62	0.82	dB	0.067
PE3W08771-24	24 inch	Insertion Loss (Typ.)	0.48	0.55	0.7	0.93	1.33	dB	0.106
PE3W08771-36	36 inch	Insertion Loss (Typ.)	0.57	0.68	0.89	1.25	1.84	dB	0.144
PE3W08771-60	60 inch	Insertion Loss (Typ.)	0.74	0.93	1.28	1.88	2.86	dB	0.22
PE3W08771-72	72 inch	Insertion Loss (Typ.)	0.83	1.05	1.48	2.19	3.38	dB	0.258

The insertion loss data for the base model does not include loss due to the connectors. Each length includes insertion loss due to the connectors.

Loss due to Connector 1:	0.2 dB
Loss due to Connector 2:	0.1 dB
Base Weight:	0.067 pounds
Additional Weight per Inch:	0.00317 pounds

Mechanical Specifications

Cable Assembly

Weight 0.067 lbs [30.39 g]

Click the following link (or enter part number in "SEARCH" on website) to obtain additional part information including price, inventory and certifications: [SMA Male Right Angle to SMA Male Cable Using PE-P195 Coax PE3W08771](#)



SMA Male Right Angle to SMA Male Cable Using PE-P195 Coax

TECHNICAL DATA SHEET

PE3W08771

Cable

Cable Type	PE-P195
Impedance	50 Ohms
Inner Conductor Type	Solid
Inner Conductor Material and Plating	Copper Clad Steel, Silver
Dielectric Type	PTFE
Number of Shields	3
Shield Layer 1	Silver Plated Copper Braid
Shield Layer 2	Aluminum Tape
Shield Layer 3	Silver Plated Copper Braid
Jacket Material	FEP, Tan
Jacket Diameter	0.195 in [4.95 mm]
Repeated Minimum Bend Radius	1 in [25.4 mm]

Connectors

Description	Connector 1	Connector 2
Type	SMA Male Right Angle Threaded	SMA Male Threaded
Specification	MIL-STD-348A	MIL-STD-348
Impedance	50 Ohms	50 Ohms
Contact Material and Plating	Brass, Gold	Brass, Gold
Contact Plating Specification	50 µin minimum	MIL-G-45204
Dielectric Type	PTFE	PTFE
Body Material and Plating	Brass, Nickel	Brass, Nickel
Body Plating Specification	100 µin minimum	QQ-N-290
Coupling Nut Material and Plating	Brass, Nickel	Brass, Nickel
Coupling Nut Plating Specification	100 µin minimum	QQ-N-290
Hex Size	5/16 inch	5/16 inch
Torque	3 in-lbs [0.34 Nm]	3 in-lbs [0.34 Nm]

Environmental Specifications

Temperature

Operating Range -55 to +165 deg C

Compliance Certifications (see [product page](#) for current document)

Plotted and Other Data

Notes:

Click the following link (or enter part number in "SEARCH" on website) to obtain additional part information including price, inventory and certifications: [SMA Male Right Angle to SMA Male Cable Using PE-P195 Coax PE3W08771](#)



SMA Male Right Angle to SMA Male Cable Using PE-P195 Coax

TECHNICAL DATA SHEET

PE3W08771

How to Order

Part Number Configuration:

PE3W08771

- **xx**

uu

Unit of Measure:
cm = Centimeters
<blank> = Inches
Length
Base Number

Example: PE3W08771-12 = 12 inches long cable
PE3W08771-100cm = 100 cm long cable

SMA Male Right Angle to SMA Male Cable Using PE-P195 Coax from Pasternack Enterprises has same day shipment for domestic and International orders. Our RF, microwave and millimeter wave products maintain a 99.4% availability and are part of the broadest selection in the industry.

Click the following link (or enter part number in "SEARCH" on website) to obtain additional part information including price, inventory and certifications: [SMA Male Right Angle to SMA Male Cable Using PE-P195 Coax PE3W08771](#)

URL: <https://www.pasternack.com/sma-male-right-angle-to-sma-male-cable-using-pe-p195-pe3w08771-p.aspx>

The information contained in this document is accurate to the best of our knowledge and representative of the part described herein. It may be necessary to make modifications to the part and/or the documentation of the part, in order to implement improvements. Pasternack reserves the right to make such changes as required. Unless otherwise stated, all specifications are nominal. Pasternack does not make any representation or warranty regarding the suitability of the part described herein for any particular purpose, and Pasternack does not assume any liability arising out of the use of any part or documentation.

PE3W08771 CAD Drawing

SMA Male Right Angle to SMA Male Cable Using PE-P195 Coax

F E D C B A

1

2

3

4

5

6

ZONE		REVISION		CHANGED BY		APPROVED BY	
REV.	DESCRIPTION	DATE	INITIAL RELEASE	DATE	INITIAL RELEASE	DATE	INITIAL RELEASE
A				11/16/2023	BPUCHASKI		AGANWANI

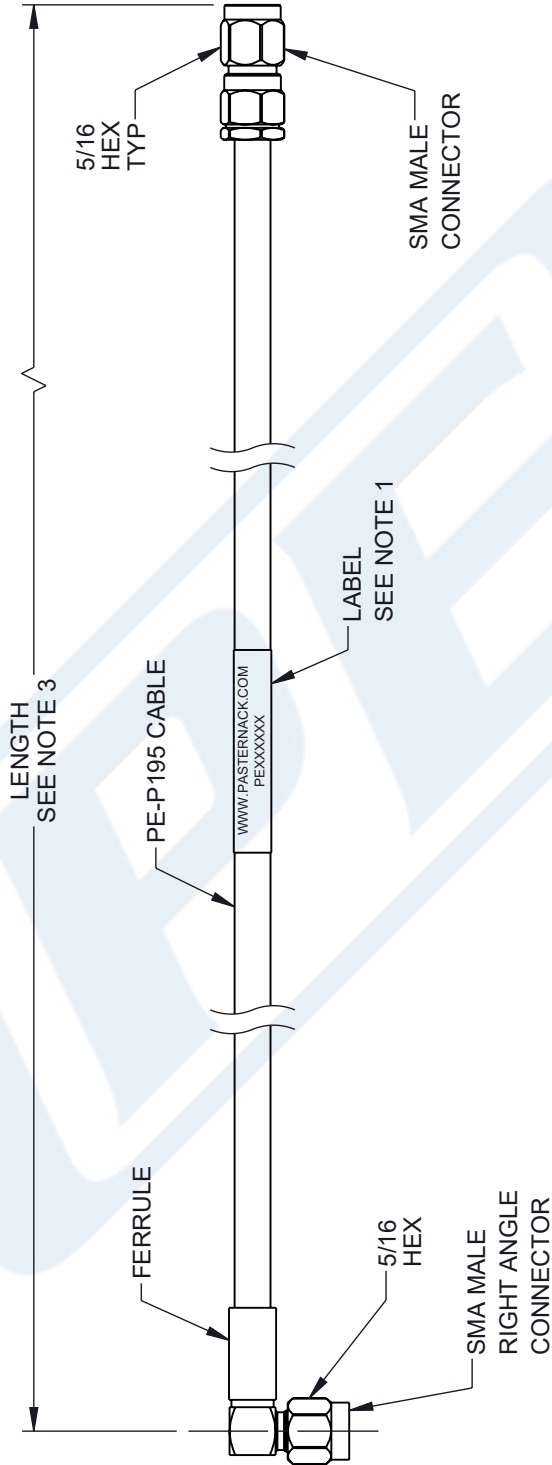

LENGTH
SEE NOTE 3

5/16
HEX
TYP

PE-P195 CABLE

WWW.PASTERNAK.COM
PEXXXXXX

LABEL
SEE NOTE 1

SMA MALE
CONNECTOR

FERRULE

5/16
HEX

SMA MALE
RIGHT ANGLE
CONNECTOR

NOTES:

- CABLE ASSEMBLY LENGTH LABEL PLACEMENT: 36 INCHES OR LESS, ONE LABEL APPROXIMATELY CENTERED. LONGER THAN 36 INCHES, TWO LABELS APPROXIMATELY 6 INCHES FROM EACH CONNECTOR.
- CABLE ASSEMBLIES SHALL BE TESTED FOR CONTINUITY.
- CABLE ASSEMBLY LENGTH DETERMINED BY ITEM PN AND DESCRIPTION

THE INFORMATION CONTAINED IN THIS DRAWING IS THE SOLE PROPERTY OF INFINITE ELECTRONICS, INC. ANY REPRODUCTION IN PART OR WHOLE WITHOUT THE WRITTEN PERMISSION OF INFINITE ELECTRONICS, INC. IS PROHIBITED. THESE COMMODITIES, TECHNOLOGY OR SOFTWARE WERE EXPORTED FROM THE UNITED STATES IN ACCORDANCE WITH THE EXPORT ADMINISTRATION REGULATIONS. DIVERSION CONTRARY TO U.S. LAW PROHIBITED.

UNLESS OTHERWISE SPECIFIED, LEADING DIMENSIONS ARE IN INCHES. DIMENSIONS IN [] ARE MILLIMETERS.			
TOLERANCES:	FRACTIONS	INTERPRET ALL DIMENSIONS AND TOLERANCES PER ASME Y14.5	
.X = ±.2 [5]	±.1/32	SCALE	NONE
.XX = ±.02 [0.5]	±.005	SHEET	1 OF 1
.XXX = ±.005 [0.13]	ANGLES ± 1°	DESCRIPTION	
CABLE LENGTH TOLERANCES:		SMA MALE RIGHT ANGLE TO SMA MALE LOW LOSS CABLE USING PE-P195 COAX	
>12 [305] ≤ 5/16 [8.0] = ±.125 / -0	>12 [305] ≤ 5/16 [8.0] = ±.125 / -0	Website: www.Pasternack.com	
>60 [1524] ≤ 120 [3048] = +4 [102] / -0	>60 [1524] ≤ 120 [3048] = +4 [102] / -0	Phone: 1.866.727.8376 1.949.261.1920	
>120 [3048] ≤ 300 [7620] = +6 [152] / -0	>120 [3048] ≤ 300 [7620] = +6 [152] / -0	SMA MALE RIGHT ANGLE TO SMA MALE LOW LOSS CABLE USING PE-P195 COAX	
>300 [7620] = +5% / -0	>300 [7620] = +5% / -0	SMA MALE RIGHT ANGLE TO SMA MALE LOW LOSS CABLE USING PE-P195 COAX	



Website: www.Pasternack.com
Phone: 1.866.727.8376 | 1.949.261.1920

SMA MALE RIGHT ANGLE TO SMA MALE LOW LOSS CABLE USING PE-P195 COAX

SIZE	CAGE CODE	DRAWN BY	ITEM NO.	REV
A	53919	BPUCHASKI	PE3W08771	A

F E D C B A