

30 dB Fixed Attenuator, N Female to N
Female Black Anodized Aluminum Heatsink
Body Rated to 25 Watts Up to 18 GHz

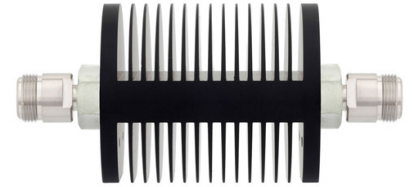

PE7371-30

Features

Applications

Description

Pasternack carries a wide range of fixed attenuators with a broad selection of attenuation levels, frequency ranges, and power dissipation ranges. RF microwave attenuators (also known as RF pads) lower the amplitude of a signal (attenuate) a known amount and can be used in a wide variety of applications. These attenuator pads are used when a signal needs to be reduced to protect measurement equipment or other circuitry, to extend the range of power meters and amplifiers, and to impedance match circuits by reducing the VSWR seen by adjacent components. RF attenuators can prevent signal overload in amplifiers, receivers and detectors, adjusting the signal level to a range that is optimal.

Few RF components are as commonly used as fixed coaxial attenuators, and Pasternack carries one of the largest in-stock varieties and ships them same day. The 30 dB Fixed Attenuator PE7371-30 is rated to 25 Watts and operates from DC to 18 GHz. The versatile coaxial package uses type N female connectors and is also REACH and RoHS compliant. The Black Anodized Aluminum Heatsink body allows for efficient heat dissipation under high power usage conditions.

Electrical Specifications

Description	Minimum	Typical	Maximum	Units
Frequency Range	DC		18	GHz
Impedance		50		Ohms
Nominal Attenuation		30		dB
VSWR			1.6:1	
Input Power, CW			25	Watts
Input Power, Peak			500	Watts

Specifications by Frequency

Description	F1	F2	F3	F4	F5	Units
Frequency Range	DC to 6	6 to 12.4	12.4 to 18			GHz
VSWR, Max	1.3:1	1.45:1	1.6:1			
Attenuation Accuracy, Typ	0.75	1	1.5			dB
Input Power, CW	25					Watts

Mechanical Specifications

Size

Length	4.5 in [114.3 mm]
Width/Diameter	2.41 in [61.21 mm]
Height	0 in [0 mm]
Weight	0.8 lbs [362.87 g]
Body Material and Plating	Black Anodized Aluminum Heatsink

30 dB Fixed Attenuator, N Female to N Female
Black Anodized Aluminum Heatsink
Body Rated to 25 Watts Up to 18 GHz

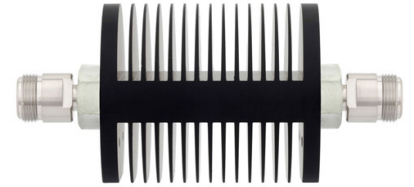

PE7371-30

Configuration		
Design	Fixed, Bidirectional	
Connectors		
Description	Connector 1	Connector 2
Type	N Female	N Female
Contact Material and Plating	Brass, Gold	Brass, Gold
Contact Plating Specification	Silver	
Outer Conductor Material and Plating		Brass, Silver
Hex Size	11/16 In.	11/16 In.
Body Material and Plating	Stainless Steel, Passivated	Stainless Steel, Passivated
Body Plating Specification	Passivated	

Environmental Specifications

Temperature	
Operating Range	-55 to +125 deg C

Compliance Certifications (see [product page](#) for current document)

Plotted and Other Data

Notes:

Typical Performance Data

30 dB Fixed Attenuator, N Female to N Female Black Anodized Aluminum Heatsink Body Rated to 25 Watts Up to 18 GHz from Pasternack Enterprises has same day shipment for domestic and International orders. Our RF, microwave and millimeter wave products maintain a 99.4% availability and are part of the broadest selection in the industry.

Click the following link (or enter part number in "SEARCH" on website) to obtain additional part information including price, inventory and certifications: [30 dB Fixed Attenuator, N Female to N Female Black Anodized Aluminum Heatsink Body Rated to 25 Watts Up to 18 GHz PE7371-30](#)

URL: <https://www.pasternack.com/30db-fixed-n-female-n-female-25-watts-attenuator-pe7371-30-p.aspx>

The information contained within this document is accurate to the best of our knowledge and representative of the part described herein. It may be necessary to make modifications to the part and/or the documentation of the part in order to implement improvements. Pasternack Enterprises reserves the right to make such changes as required. Unless otherwise stated, all specifications are nominal. Pasternack Enterprises does not make any representation or warranty regarding the suitability of the part described herein for any particular purpose, and Pasternack Enterprises does not assume liability arising out of the use of any part or document.

PE7371-30 CAD Drawing

30 dB Fixed Attenuator, N Female to N Female Black Anodized Aluminum Heatsink Body Rated to 25 Watts Up to 18 GHz

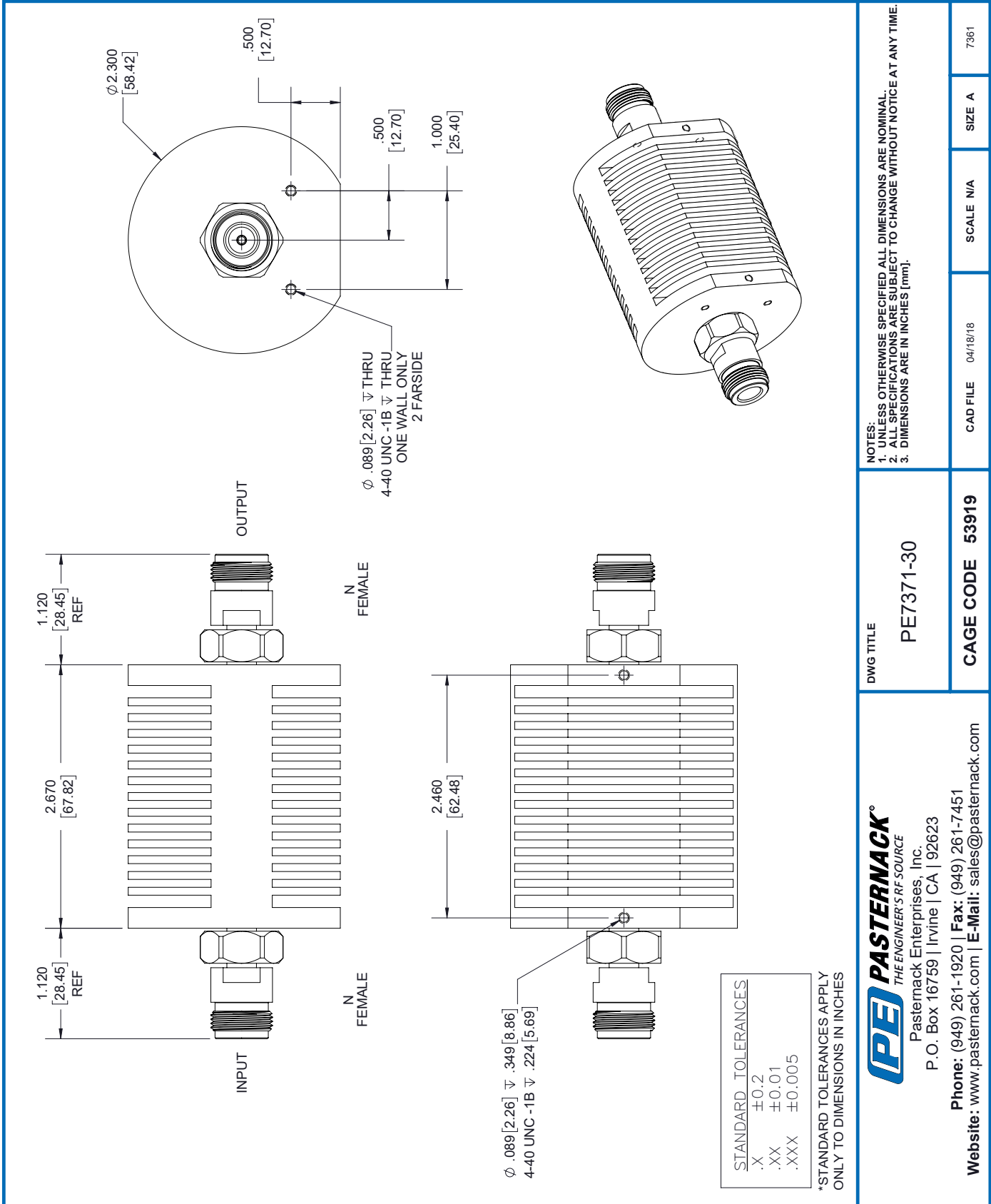

THE ENGINEER'S RF SOURCE
 Pasternack Enterprises, Inc.
 P.O. Box 16759 | Irvine | CA | 92623

Phone: (949) 261-1920 | **Fax:** (949) 261-7451
Website: www.pasternack.com | **E-Mail:** sales@pasternack.com