

**NOTICE OF PROPRIETARY RIGHTS** THIS DOCUMENT CONTAINS CONFIDENTIAL TECHNICAL DATA, INCLUDING TRADE SECRETS, PROPRIETARY TO TIMES MICROWAVE SYSTEMS. DISCLOSURE OF THIS DATA IS EXPRESSLY CONDITIONED UPON YOUR ASSENT THAT ITS USE IS LIMITED TO USE WITHIN YOUR COMPANY ONLY. ANY OTHER USE IS STRICTLY PROHIBITED WITHOUT THE PRIOR WRITTEN CONSENT OF TIMES MICROWAVE SYSTEMS.

SYM	REVISION DESCRIPTION	DFTM	DATE	APPD	DATE
A	RELEASED FOR PRODUCTION	N. N. N	1/15/14	J. D. B.	1/15/14



**NOTES:**

- ASSEMBLED CONNECTOR INTERFACE IS DESIGNED IN ACCORDANCE WITH MIL-STD-348.
- MATERIAL:**  
 BODY, CONTACT - BRASS PER ASTM B16, C36000 ALLOY, TEMPER H02  
 INSULATOR - TEFLON PER ASTM D1710, TYPE 1, GRADE 1, CLASS A  
 SHRINK SLEEVE - HEAT SHRINKABLE ATUM PER MIL-I-23053/4 (NOT SHOWN)  
 CRIMP SLEEVE - D.H.P. COPPER CDA, ALLOY #122, TEMPER HARD  
 GASKET - SILICONE RUBBER PER A-A-59588, 50-75 DUREMETER  
 LOCKING RING - PHOSPHOR BRONZE PER ASTM B139, C54400 ALLOY, TEMPER HD
- FINISH:**  
 CONTACT - GOLD PLATE PER ASTM B488  
 CRIMP SLEEVE - SILVER PLATE PER ASTM B700  
 ALL OTHER METAL PARTS - ALBALOY PLATE

MATERIAL:	UNLESS OTHERWISE SPECIFIED ALL DIMENSIONS ARE IN INCHES MACHINED SURFACES FINISH 63 RMS MAX. REMOVE ALL BURRS .004 MAX. BREAK MACHINE CORNERS .005 MAX. FILLET R. TOLERANCES ON DECIMALS .XX $\pm .01$ .XXX $\pm .005$ ANGLES $\pm 1^\circ$ FRACTIONS $\pm 1/64$	DFTM. N. N. N	TIMES MICROWAVE SYSTEMS	
		DATE 1/15/14		
USED ON: -		CHKD. J. D. B.	TC-195-NMH-X CONNECTOR ASSEMBLY N Male for LMR-195	
		DATE 1/15/14		
SCALE: NONE	DWG. SIZE A	APPD. J. D. B.	SHEET 1 of 1 SD3190-2880 REV A	
		DATE 1/15/14		
DO NOT SCALE DRAWING	CODE IDENT 68999			

**NOTICE OF PROPRIETARY RIGHTS** THIS DOCUMENT CONTAINS CONFIDENTIAL TECHNICAL DATA, INCLUDING TRADE SECRETS, PROPRIETARY TO TIMES MICROWAVE SYSTEMS. DISCLOSURE OF THIS DATA IS EXPRESSLY CONDITIONED UPON YOUR ASSENT THAT ITS USE IS LIMITED TO USE WITHIN YOUR COMPANY ONLY. ANY OTHER USE IS STRICTLY PROHIBITED WITHOUT THE PRIOR WRITTEN CONSENT OF TIMES MICROWAVE SYSTEMS.

SYM	REVISION DESCRIPTION	DFTM	DATE	APPD	DATE
A	RELEASED FOR PRODUCTION	D. J. H.	1/13/09	J. D. B.	1/13/09
B	CHANGED PER CDC #40023	D. J. H.	6/2/14	J. D. B.	6/4/14

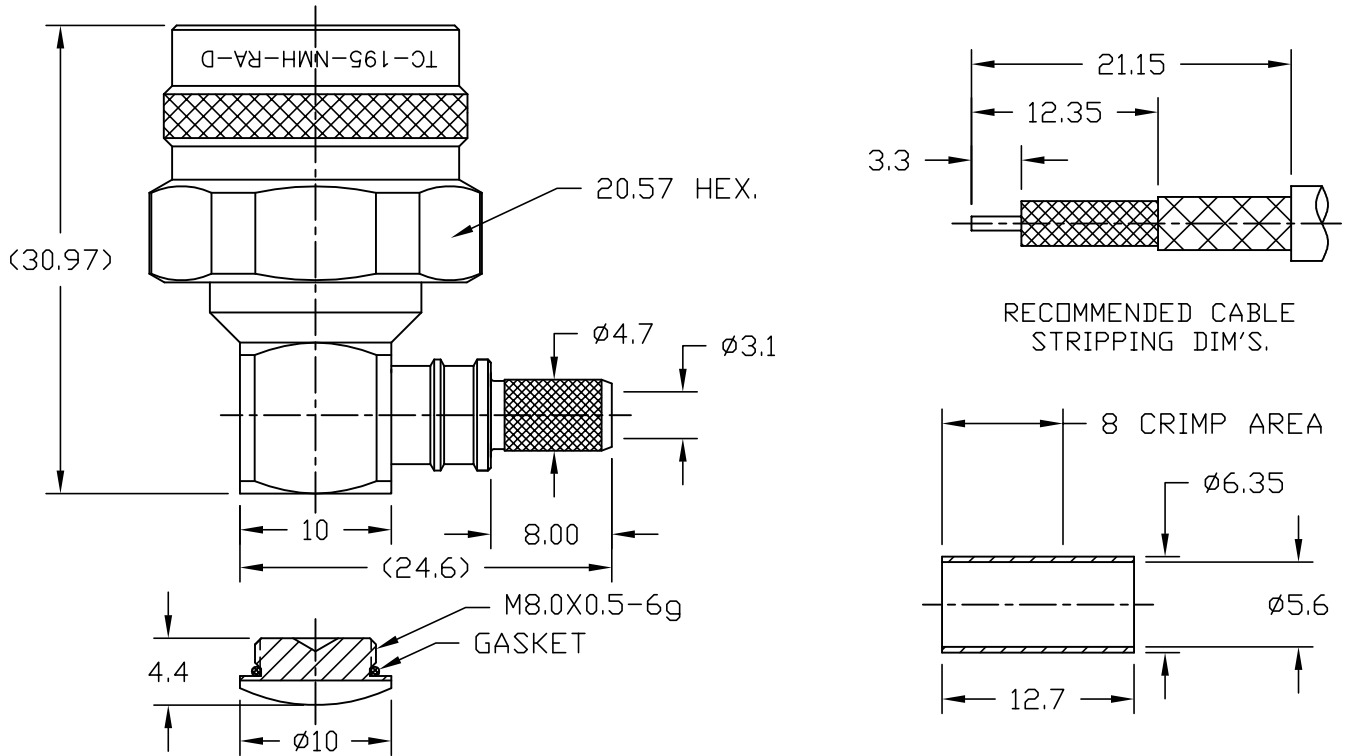

**NOTES:**

- CONTACT PIN IS SOLDERED.
- FERRULE IS CRIMPED TO .217" HEX.

**ALL PARTS SATISFIED ROHS REQUIREMENTS**

MATERIALS AND PLATING		UNIT: MICRO-INCHES
BODY, SHELL	BRASS C3604	ALBALOY 80μ"/COPPER
CONTACT PIN	BRASS C3604	GOLD 50μ"/COPPER
INSULATOR	TEFLON MIL-P-19468	NATURAL
FERRULE	BRASS	ALBALOY 80μ"/COPPER
GASKET	SILICONE	RED

ELECTRICAL CHARACTERISTICS	
Impedance	50 Ω
Voltage rating	750 V(rms)
Frequency range	0~6 GHz
Dielectric withstanding voltage	1000V
Contact resistance	Center contact ≤ 3 mΩ Outer contact ≤ 2 mΩ
Insulation resistance	≥ 5000MΩ
Insertion loss	According as the cable
VSWR	≤ 1.2 (DC-2GHz) ≤ 1.3 (DC-6GHz)

MECHANICAL CHARACTERISTICS	
Force to engage and disengage	6 lbs MAX.
Center contact retention force	6 lbs MIN.
Recommended Coupling torque	6-10 in-lbs.
Coupling nut retention force	100 lbs MIN.
Durability	≥ 500 cycles

ENVIRONMENTAL CHARACTERISTICS	
Temperature range	-55°C - +155°C
Thermal shock	US MIL- STD 202, Meth. 107, Cond. B
Vibration	US MIL- STD 202, Meth. 204, Cond. B
Shock	US MIL- STD 202, Meth. 213, Cond. I
Climatic class	IEC 60068 65/165/21

MATERIAL:	UNLESS OTHERWISE SPECIFIED ALL DIMENSIONS ARE IN mm MACHINED SURFACES FINISH 1.6 RMS MAX. REMOVE ALL BURRS 0.15X45° MAX. BREAK MACHINE CORNERS 0.15X45° MAX. FILLET R. TOLERANCES ON DECIMALS .X ± 0.3 .XX ± 0.2 ANGLES ± 3° FRACTIONS ± N/A	DFTM: D. J. H.	TIMES MICROWAVE SYSTEMS
		DATE: 1/13/09	
USED ON: B		CHKD: J. D. B.	<b>TC-195-NMH-RA-D</b> 90° "N" MALE FOR LMR-195 CABLE
		DATE: 1/13/09	
SCALE: N/A	DWG. SIZE: A	APPD: J. D. B.	SHEET: 1 of 1
		DATE: 1/13/09	
DO NOT SCALE DRAWING	CODE IDENT: 68999	DATE: 1/13/09	REV: B



## Low Loss Flexible PE-P195 Coax Cable Triple Shielded with Tan FEP Jacket

### RF Cables Technical Data Sheet

PE-P195

#### Configuration

- Low Loss Flexible Cable
- 3 Shield(s)

#### Electrical Specifications

Description	Minimum	Typical	Maximum	Units
Frequency Range	DC		22	GHz
Impedance		50		Ohms
Velocity of Propagation		70		%
Operating Voltage (AC)			1,900	Vrms
Dielectric Withstanding Voltage (AC)			5,000	Vrms
Nominal Capacitance		29 [95.14]		pF/ft [pF/m]

#### Performance by Frequency Band

Description	F1	F2	F3	F4	F5	Units
Frequency	0.1	0.5	1	5	10	GHz
Attenuation, Typ	3.9	8.8	12.5	31.5	45	dB/100ft
	12.8	28.87	41.01	103.35	147.64	dB/100m

Description	F6	F7	F8	F9	F10	Units
Frequency	15	18	20	22		GHz
Attenuation, Typ	58	65	69	73		dB/100ft
	190.29	213.25	226.38	239.5		dB/100m

#### Mechanical Specifications

Diameter	0.195 in [4.95 mm]
Weight	0.038 lbs/ft [0.06 Kg/m]
Min. Bend Radius (Repeated)	1 in [25.4 mm]

Click the following link (or enter part number in "SEARCH" on website) to obtain additional part information including price, inventory and certifications: [Low Loss Flexible PE-P195 Coax Cable Triple Shielded with Tan FEP Jacket PE-P195](#)



# Low Loss Flexible PE-P195 Coax Cable Triple Shielded with Tan FEP Jacket

## RF Cables Technical Data Sheet

PE-P195

### Construction Specifications

Description	Material and Plating	Diameter
Inner Conductor	Copper Clad Steel, Silver, 1 Strands	0.037 in [0.94 mm]
Conductor Type	Solid	
Dielectric	PTFE	0.116 in [2.95 mm]
First Shield	Silver Plated Copper Braid 96% coverage	0.126 in [3.2 mm]
Second Shield	Aluminum Tape	0.132 in [3.35 mm]
Third Shield	Silver Plated Copper Braid 96% coverage	0.155 in [3.94 mm]
Jacket	FEP, Tan	0.195 in [4.95 mm]

### Environmental Specifications

#### Temperature

Operating Range -55 to +200 deg C

### Compliance Certifications (see [product page](#) for current document)

### Plotted and Other Data

Notes:

Low Loss Flexible PE-P195 Coax Cable Triple Shielded with Tan FEP Jacket from Pasternack Enterprises has same day shipment for domestic and International orders. Our RF, microwave and millimeter wave products maintain a 99.4% availability and are part of the broadest selection in the industry.

Click the following link (or enter part number in "SEARCH" on website) to obtain additional part information including price, inventory and certifications: [Low Loss Flexible PE-P195 Coax Cable Triple Shielded with Tan FEP Jacket PE-P195](#)

URL: <https://www.pasternack.com/precision-0.195-rg142-solid-center-conductor-52-ohm-coax-cable-fep-jacket-pe-p195-p.aspx>

The information contained in this document is accurate to the best of our knowledge and representative of the part described herein. It may be necessary to make modifications to the part and/or the documentation of the part, in order to implement improvements. Pasternack reserves the right to make such changes as required. Unless otherwise stated, all specifications are nominal. Pasternack does not make any representation or warranty regarding the suitability of the part described herein for any particular purpose, and Pasternack does not assume any liability arising out of the use of any part or documentation.

# PE-P195 CAD Drawing

Low Loss Flexible PE-P195 Coax Cable Triple Shielded with Tan FEP Jacket

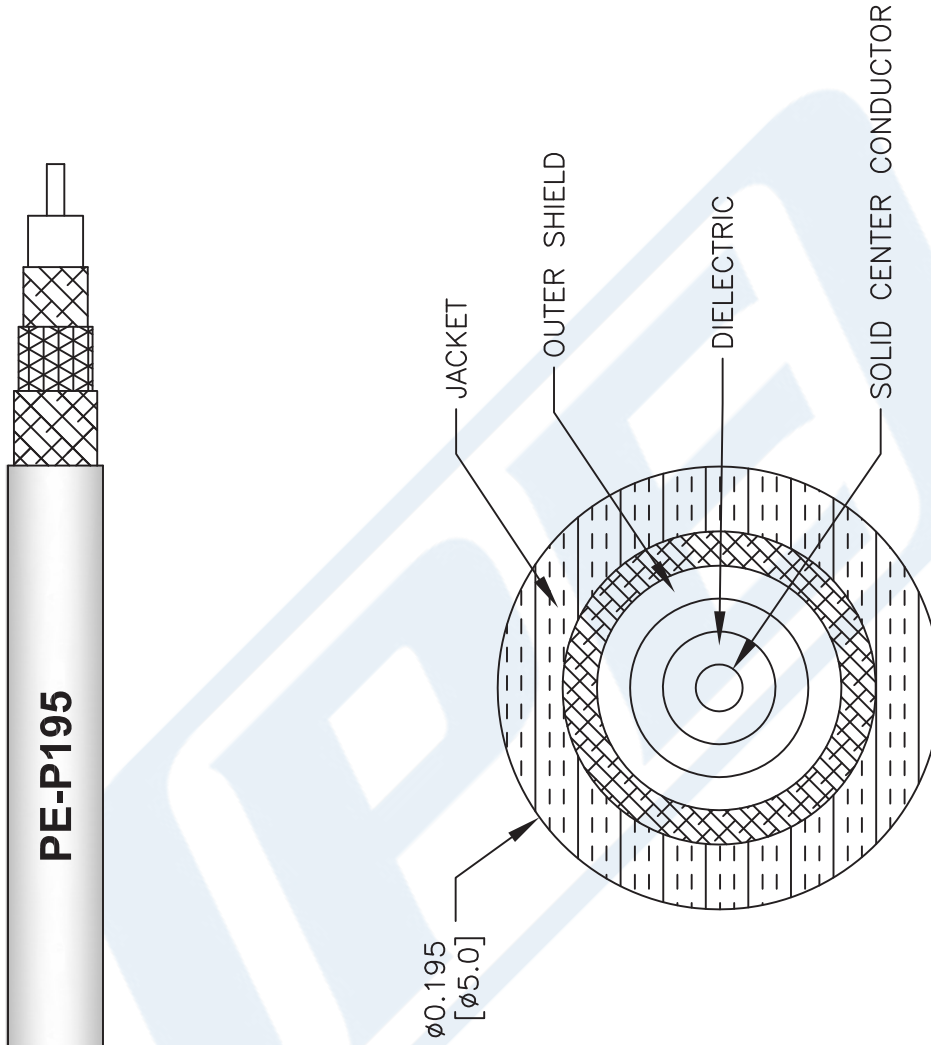

NOTES:  
 1. UNLESS OTHERWISE SPECIFIED ALL DIMENSIONS ARE NOMINAL.  
 2. ALL SPECIFICATIONS ARE SUBJECT TO CHANGE WITHOUT NOTICE AT ANY TIME.  
 3. DIMENSIONS ARE IN INCHES [mm].

DWG TITLE	
<b>PE-P195</b>	
FSCM NO. 53919	CAD FILE 111716
SCALE N/A	SIZE A
	41742

**PE PASTERNAK**  
 THE ENGINEER'S RF SOURCE  
 Pasternack Enterprises, Inc.  
 P.O. Box 16759 | Irvine | CA | 92623  
 Phone: (949) 261-1920 | Fax: (949) 261-7451  
 Website: www.pasternack.com | E-Mail: sales@pasternack.com