

**NOTICE OF PROPRIETARY RIGHTS** THIS DOCUMENT CONTAINS CONFIDENTIAL TECHNICAL DATA, INCLUDING TRADE SECRETS, PROPRIETARY TO TIMES MICROWAVE SYSTEMS. DISCLOSURE OF THIS DATA IS EXPRESSLY CONDITIONED UPON YOUR ASSENT THAT ITS USE IS LIMITED TO USE WITHIN YOUR COMPANY ONLY. ANY OTHER USE IS STRICTLY PROHIBITED WITHOUT THE PRIOR WRITTEN CONSENT OF TIMES MICROWAVE SYSTEMS.

SYM	REVISION DESCRIPTION	DFTM	DATE	APPD	DATE
A	RELEASED FOR PRODUCTION	N.N.N	2/13/14	J.D.B.	2/14/14
B	CHANGED PER CDC #40047	N.N.N	6/6/14	J.D.B.	6/6/14

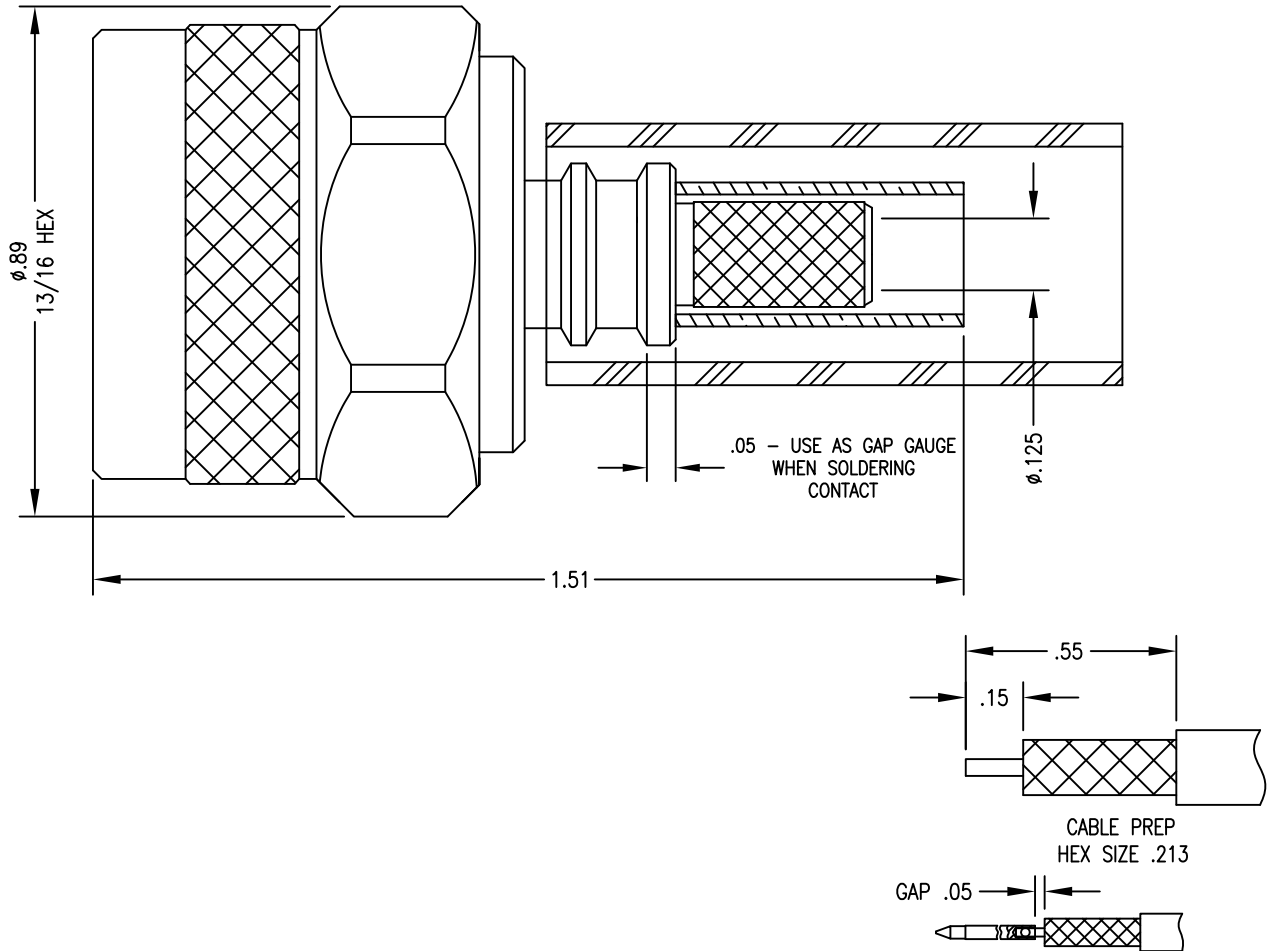

- |   |  |                               |
|---|--|-------------------------------|
| 1.0 PERFORMANCE                         | 2.0 MATERIALS                          | 3.0 FINISHES: SEE TABLE       |
| 1.1 FREQUENCY RANGE: DC-6 GHz           | 2.1 DIELECTRIC: PTFE                   | 4.0 MECHANICAL                |
| 1.2 NOMINAL IMPEDANCE: 50 OHMS          | 2.2 CONTACT: BRASS                     | 4.1 INTERFACE PER MIL-STD-348 |
| 1.3 DWV: 1,000 VRMS @ 60 Hz (SEA LEVEL) | 2.3 LOCKING RING: PHOSPHOR BRONZE      |                               |
| 1.4 TEMPERATURE RANGE: -65°C TO +165°C  | 2.4 CRIMP FERRULE: SOFT COPPER         |                               |
|   | 2.5 OTHER METAL PARTS: BRASS           |                               |
|   | 2.6 GASKET: SILICONE RUBBER            |                               |
|   | 2.7 HEAT SHRINK: POLYOLEFIN THICK WALL |                               |

BODY	CONTACT
ALBALOY	GOLD/NI

MATL:	UNLESS OTHERWISE SPECIFIED ALL DIMENSIONS ARE IN INCHES MACHINED SURFACES FINISH N/A RMS MAX. REMOVE ALL BURRS .005 MAX. BREAK MACHINE CORNERS .005 MAX. FILLET R. TOLERANCES ON DECIMALS . XX ± .03 . XXX ± .005 ANGLES ± 1° FRACTIONS ± 1/32	DFTM. N. N. N	TIMES MICROWAVE SYSTEMS
		DATE 2/13/14	
USED ON: D		CHKD. J. D. B.	<b>TC-200-NMH-X</b> NM FOR LMR-200 CABLE
		DATE 2/14/14	
SCALE: N/A	DWG. SIZE A	APPD. J. D. B.	SHEET 1 of 1
		DATE 2/14/14	
DO NOT SCALE DRAWING	CODE IDENT 68999	DATE 2/14/14	REV B

**NOTICE OF PROPRIETARY RIGHTS** THIS DOCUMENT CONTAINS CONFIDENTIAL TECHNICAL DATA, INCLUDING TRADE SECRETS, PROPRIETARY TO TIMES MICROWAVE SYSTEMS. DISCLOSURE OF THIS DATA IS EXPRESSLY CONDITIONED UPON YOUR ASSENT THAT ITS USE IS LIMITED TO USE WITHIN YOUR COMPANY ONLY. ANY OTHER USE IS STRICTLY PROHIBITED WITHOUT THE PRIOR WRITTEN CONSENT OF TIMES MICROWAVE SYSTEMS.

SYM	REVISION DESCRIPTION	DFTM	DATE	APPD	DATE
A	RELEASED FOR PRODUCTION	N.N.N	2/13/14	J.D.B.	2/14/14
B	CHANGED PER CDC #40047	N.N.N	6/6/14	J.D.B.	6/6/14

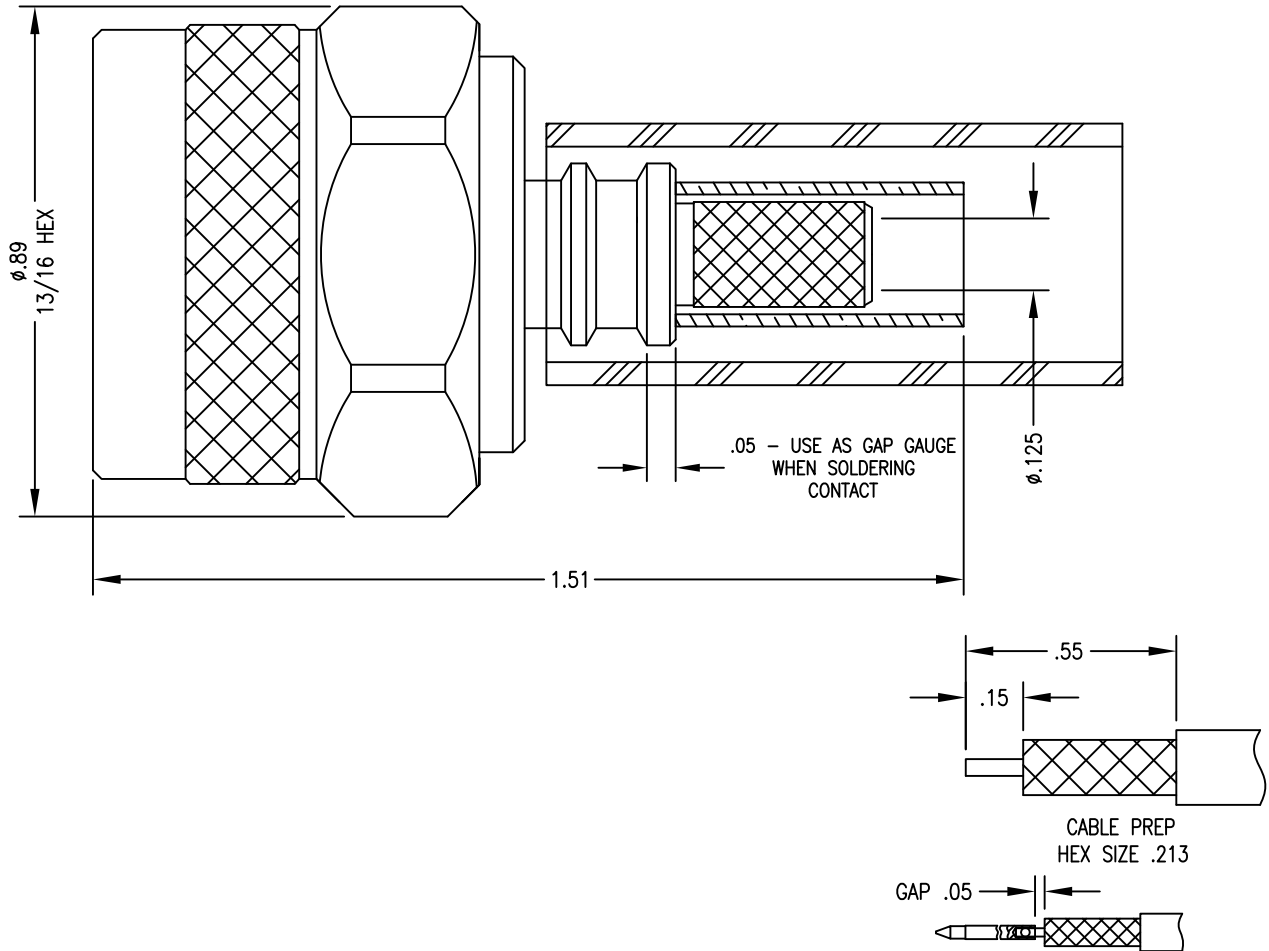

- |   |  |                               |
|---|--|-------------------------------|
| 1.0 PERFORMANCE                         | 2.0 MATERIALS                          | 3.0 FINISHES: SEE TABLE       |
| 1.1 FREQUENCY RANGE: DC-6 GHz           | 2.1 DIELECTRIC: PTFE                   | 4.0 MECHANICAL                |
| 1.2 NOMINAL IMPEDANCE: 50 OHMS          | 2.2 CONTACT: BRASS                     | 4.1 INTERFACE PER MIL-STD-348 |
| 1.3 DWV: 1,000 VRMS @ 60 Hz (SEA LEVEL) | 2.3 LOCKING RING: PHOSPHOR BRONZE      |                               |
| 1.4 TEMPERATURE RANGE: -65°C TO +165°C  | 2.4 CRIMP FERRULE: SOFT COPPER         |                               |
|   | 2.5 OTHER METAL PARTS: BRASS           |                               |
|   | 2.6 GASKET: SILICONE RUBBER            |                               |
|   | 2.7 HEAT SHRINK: POLYOLEFIN THICK WALL |                               |

BODY	CONTACT
ALBALOY	GOLD/NI

MATL:	UNLESS OTHERWISE SPECIFIED ALL DIMENSIONS ARE IN INCHES MACHINED SURFACES FINISH N/A RMS MAX. REMOVE ALL BURRS .005 MAX. BREAK MACHINE CORNERS .005 MAX. FILLET R. TOLERANCES ON DECIMALS .XX ± .03 .XXX ± .005 ANGLES ± 1° FRACTIONS ± 1/32	DFTM. N. N. N	TIMES MICROWAVE SYSTEMS	
		DATE 2/13/14		
USED ON: D		CHKD. J. D. B.	<b>TC-200-NMH-X</b> NM FOR LMR-200 CABLE	
		DATE 2/14/14		
SCALE: N/A	DWG. SIZE A	APPD. J. D. B.	1 of 1   SD3190-2882   B	
		DATE 2/14/14		
DO NOT SCALE DRAWING	CODE IDENT 68999			

# LMR<sup>®</sup>-200-UF UltraFlex Communications Coax

## Ideal for...

- Jumper Assemblies in Wireless Communications Systems
- Short Antenna Feeder runs
- Any application that requires periodic/repeated flexing



• **LMR<sup>®</sup> - UltraFlex** has a stranded center conductor and rubber outer jacket designed for multiple bending/flexing cycles. It is used for both indoor and outdoor applications.

• **Flexibility** and bendability are hallmarks of the LMR-200-UF cable design. The flexible outer conductor enables the tightest bend radius available for any cable of similar size and performance.

• **Low Loss** is another hallmark feature of LMR-200-UF. Size for size LMR has the lowest loss of any flexible cable and comparable loss to semirigid hard-line cables.

• **RF Shielding** is 50 dB greater than typical single shielded coax (40 dB). The multi-ply bonded foil outer conductor is rated conservatively at > 90 dB (i.e. >180 dB between two adjacent cables).

• **Weatherability:** LMR-200-UF cables are designed for outdoor exposure and have a life expectancy in excess of 10 years.

• **Connectors:** A wide variety of connectors are available for LMR-200-UF cable, including all common interface types, reverse polarity, and solder-on center pins. Most LMR connectors employ crimp outer attachment using standard hex crimp sizes.

• **Cable Assemblies:** All LMR-200-UF cable types are available as pre-terminated cable assemblies. Refer to the section on FlexTech for further details.

Construction Specifications			
Description	Material	In.	(mm)
Inner Conductor	Stranded BC	0.044	(1.12)
Dielectric	Foam Polyethylene	0.116	(2.95)
Outer Conductor	Aluminum Tape	0.121	(3.07)
Overall Braid	Tinned Copper	0.144	(3.66)
Jacket	Black Thermoplastic Elastomer	0.195	(4.95)

Mechanical Specifications			
Performance Property	Units	US	(metric)
Bend Radius: installation	in. (mm)	0.5	(12.7)
Bend Radius: repeated	in. (mm)	2	(50.8)
Bending Moment	ft-lb (N-m)	0.1	(0.14)
Weight	lb/ft (kg/m)	0.022	(0.03)
Tensile Strength	lb (kg)	40	(18.2)
Flat Plate Crush	lb/in. (kg/mm)	10	(0.18)

Environmental Specifications			
Performance Property	°F		°C
Installation Temperature Range	-40/+185		-40/+85
Storage Temperature Range	-94/+185		-70/+85
Operating Temperature Range	-40/+185		-40/+85

Electrical Specifications			
Performance Property	Units	US	(metric)
Velocity of Propagation	%	83	
Dielectric Constant	NA	1.45	
Time Delay	nS/ft (nS/m)	1.22	(4.02)
Impedance	ohms	50	
Capacitance	pF/ft (pF/m)	24.5	(80.3)
Inductance	uH/ft (uH/m)	0.061	(0.20)
Shielding Effectiveness	dB	>90	
DC Resistance			
Inner Conductor	ohms/1000ft (/km)	7.5	(24.6)
Outer Conductor	ohms/1000ft (/km)	4.9	(16.1)
Voltage Withstand	Volts DC	1000	
Jacket Spark	Volts RMS	3000	
Peak Power	kW	2.5	

Part Description				
Part Number	Application	Jacket	Color	Stock Code
LMR-200-UF	Indoor/Outdoor	TPE	Black	54042

**Attenuation vs. Frequency (typical)**

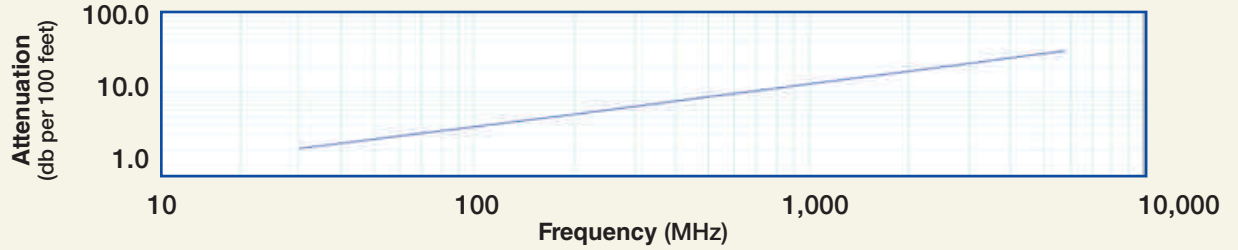

Frequency (MHz)	30	50	150	220	450	900	1500	1800	2000	2500	5800
Attenuation dB/100 ft	2.1	2.7	4.8	5.8	8.3	11.9	15.5	17.1	18.0	20.2	31.6
Attenuation dB/100 m	7.0	9.0	15.7	19.0	27.4	39.1	50.9	55.9	59.1	66.4	103.8
Avg. Power kW	0.95	0.73	0.42	0.35	0.24	0.17	0.13	0.12	0.11	0.10	0.06

Calculate Attenuation =  $(0.385082) \cdot \sqrt{\text{FMHz}} + (0.000396) \cdot \text{FMHz}$  (interactive calculator available at [http://www.timesmicrowave.com/cable\\_calculators](http://www.timesmicrowave.com/cable_calculators))  
 Attenuation: VSWR=1.0 ; Ambient = +25°C (77°F) Power: VSWR=1.0; Ambient = +40°C; Inner Conductor = 100°C (212°F);  
 Sea Level; dry air; atmospheric pressure; no solar loading



**Connectors**

Interface	Description	Part Number	Stock Code	VSWR** Freq. (GHz)	Coupling Nut	Inner Contact Attach	Outer Contact Attach	Finish* Body /Pin	Length in (mm)	Width in (mm)	Weight lb (g)
BNC male	Straight Plug	TC-200-BM	3190-225	<1.25:1 (2.5)	Knurl	Solder	Crimp	S/G	1.7 (43.2)	0.56(14.2)	0.045 (20.4)
Mini-UHF	Straight Plug	TC-200-MUHF	3190-444	<1.25:1 (2.5)	Knurl	Solder	Crimp	NG	1.1 (27.9)	0.45(11.4)	0.015 (6.8)
N male	Straight Plug	TC-200-NM	3190-224	<1.25:1 (2.5)	Knurl	Solder	Crimp	S/G	1.5 (38.1)	0.75(19.1)	0.073 (33.1)
SMA male	Straight Plug	TC-200-SM	3190-612	<1.25:1 (8)	Hex	Solder	Crimp	SS/G	1.0 (25.4)	0.32(8.1)	0.015(6.8)
SMA male	Reverse Polarity	TC-200-SM-RP	3190-327	<1.25:1 (2.5)	Hex	Solder	Crimp	SS/G	1.0 (25.4)	0.32(8.1)	0.015(6.8)
TNC male	Straight Plug	TC-200-TMC	3190-240	<1.25:1 (2.5)	Knurl	Solder	Clamp	S/G	1.7 (43.2)	0.59(15.0)	0.045 (20.4)
TNC female	Straight Jack	TC-200-TF	3190-263	<1.25:1 (2.5)	NA	Solder	Crimp	N/G	1.3 (33.0)	0.57(14.5)	0.033 (15.0)

\* Finish metals: N=Nickel, S=Silver, G=Gold, SS=Stainless Steel, A=Alballoy \*\*VSWR spec based on 3 foot cable with a connector pair

**Hardware Accessories**

Type	Part Number	Stock Code	Description
Ground Kit	GK-S200TT	GK-S200TT	Standard Ground Kit (each)



**Install Tools**

Type	Part Number	Stock Code	Description
Crimp Tool	CT-240/200/195/100	3190-667	Crimp tool for LMR-100, 195, 200 and 240 connectors
Cutting Tool	CCT-01	3190-1544	Cable end flush cut tool
Replacement Blade	RB-01	3190-1609	Replacement blade for cutting tool

