

NOTICE OF PROPRIETARY RIGHTS THIS DOCUMENT CONTAINS CONFIDENTIAL TECHNICAL DATA, INCLUDING TRADE SECRETS, PROPRIETARY TO TIMES MICROWAVE SYSTEMS. DISCLOSURE OF THIS DATA IS EXPRESSLY CONDITIONED UPON YOUR ASSENT THAT ITS USE IS LIMITED TO USE WITHIN YOUR COMPANY ONLY. ANY OTHER USE IS STRICTLY PROHIBITED WITHOUT THE PRIOR WRITTEN CONSENT OF TIMES MICROWAVE SYSTEMS.

SYM	REVISION DESCRIPTION	DFTM	DATE	APPD	DATE
A	RELEASED FOR PRODUCTION	K.A.M.	5/23/11	J.D.B.	6/9/11
B	CHANGED PER CDC #37302	D.J.H.	3/22/13	J.D.B.	3/25/13

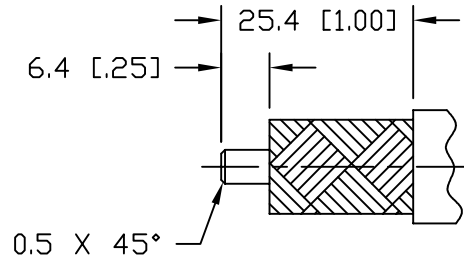

CABLE PREP.
USE CST-600
(3192-052)
.610" HEX.

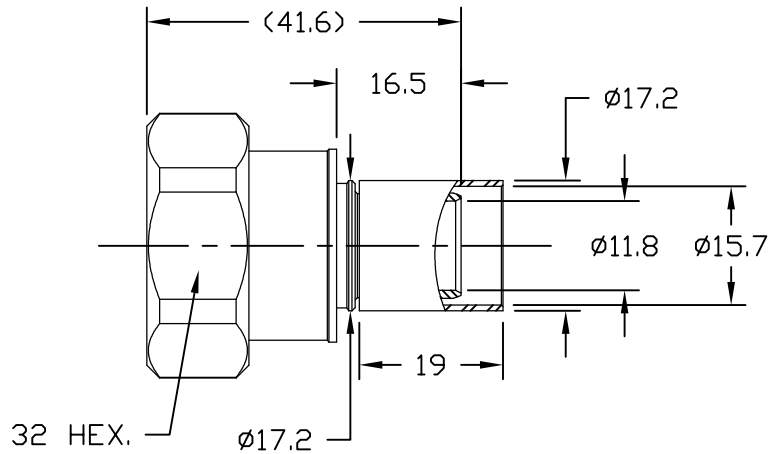

Reference Standard IEC60169-4

I. Electric Performance

Nominal Impedance(Ω):	50
Frequency Range:	DC-3GHz
VSWR:	≤ 1.15
Insert Loss(dB):	≤ 0.05
Insulation resistance(M Ω)	≥ 10000
Proof Voltage(V)	2500
Conductor resistance(m Ω)	outer conductor <0.2 inner conductor <0.8

II. Mechanical Performance

Nut Torque	25N.m
(Nut)Whorl pull	1000N
Tensile force(cable-connect)	500N
Torsion(cable-connect)	5N.m

III. Material and plating

Component	Material	Plating
Inner conductor	Spring Copper	Ag 5 μ m
Outer conductor	Brass	Copper-tin-zinc 2 μ m
Tube	Copper	Copper-tin-zinc 2 μ m
Nut	Brass	Nickel 5 μ m
Gasket	Silicone Rubber	
Insulator	PTFE	

IV. Environment

Temp. range	-55 $^{\circ}$ C~+155 $^{\circ}$ C
Weather standard	IEC 60068 55 / 155/ 56
Thermal shock	US MIL-STD 202,Meth.107,Cond.B
Vibration	US MIL-STD 202,Meth.204,Cond.B
Shock	US MIL-STD 202,Meth.213,Cond.I
Waterproofing standard	IP68
ROHS Compliant	

V. Assembly: inner conductor installed and outer conductor crimped

MATL:	UNLESS OTHERWISE SPECIFIED	DFTM. K. A. M.	TIMES MICROWAVE SYSTEMS
	ALL DIMENSIONS ARE IN mm MACHINED SURFACES FINISH N/A RMS MAX. REMOVE ALL BURRS N/A MAX. BREAK MACHINE CORNERS N/A MAX. FILLET R. TOLERANCES ON DECIMALS . XX \pm N/A . XXX \pm N/A ANGLES \pm 1 $^{\circ}$ FRACTIONS \pm N/A	DATE 5/23/11	
USED ON: 0-0	DO NOT SCALE DRAWING	CHKD. J. D. B.	EZ-600-716M-X 7-16 MALE FOR LMR-600 CABLE EZ/CRIMP/NO BRAID TRIM
		DATE 6/9/11	
SCALE: N/A	DWG. SIZE A	APPD. J. D. B.	SHEET 1 of 1 SD3190-2643 REV B
	CODE IDENT 68999	DATE 6/9/11	

Installation Instruction

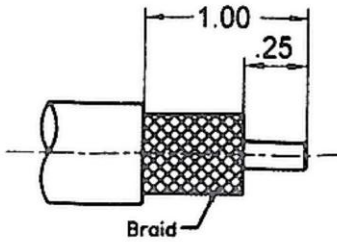

1. A. Trim cable to dimensions shown. Be careful to avoid nicking the braid
B. Remove any residual plastic from center conductor
C. Deburr center conductor using a fine file or Times DBT-U tools
D. Avoid nicking aluminum tape or center conductor

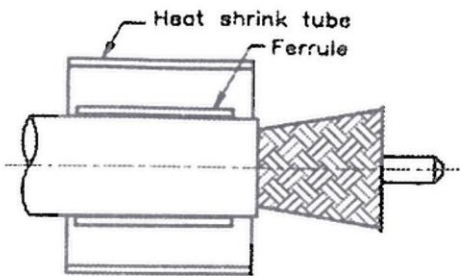

2. A. Slide crimp ferrule and heat shrink tube over the cable
B. Flare the braid

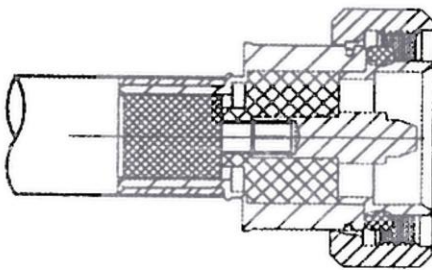

3. A. Insert Cable into connector body until dielectric is seated and center conductor is inserted fully into connector center pin.

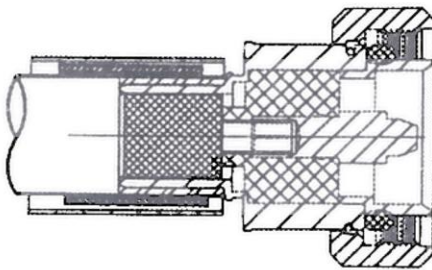

4. A. Slide crimp ferrule over braid and crimp as close to body as possible using .429" HEX crimp tooling. Pay attention to the crimp area, do not crimp rear of crimp sleeve
B. Heat shrink tube over rear of connector body and down on to cable jacket using hot air gun

NOTICE OF PROPRIETARY RIGHTS THIS DOCUMENT CONTAINS CONFIDENTIAL TECHNICAL DATA, INCLUDING TRADE SECRETS, PROPRIETARY TO TIMES MICROWAVE SYSTEMS. DISCLOSURE OF THIS DATA IS EXPRESSLY CONDITIONED UPON YOUR ASSENT THAT ITS USE IS LIMITED TO USE WITHIN YOUR COMPANY ONLY. ANY OTHER USE IS STRICTLY PROHIBITED WITHOUT THE PRIOR WRITTEN CONSENT OF TIMES MICROWAVE SYSTEMS.

SYM	REVISION DESCRIPTION	DFTM	DATE	APPD	DATE
A	RELEASED FOR PRODUCTION	K.A.M.	5/23/11	J.D.B.	6/9/11
B	CHANGED PER CDC #37302	D.J.H.	3/22/13	J.D.B.	3/25/13

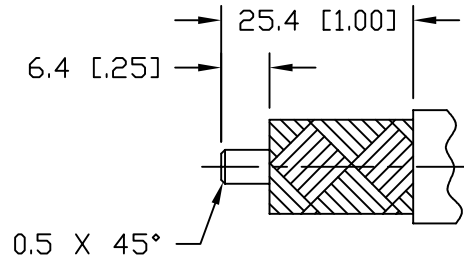

CABLE PREP.
USE CST-600
(3192-052)
.610" HEX.

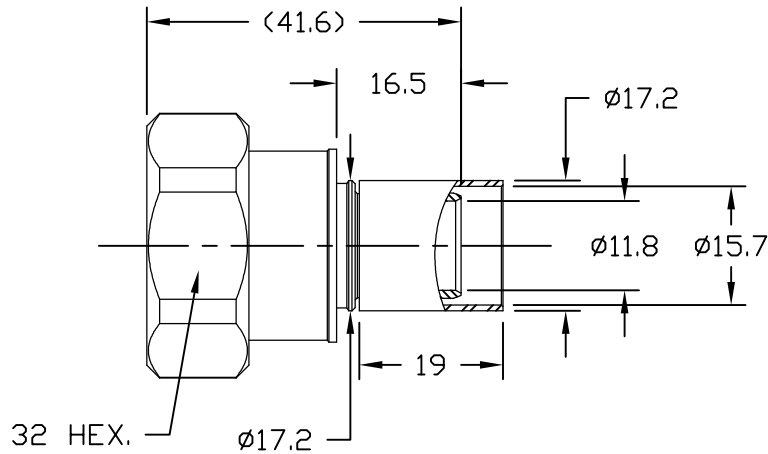

Reference Standard IEC60169-4

I. Electric Performance

Nominal Impedance(Ω):	50
Frequency Range:	DC-3GHz
VSWR:	≤ 1.15
Insert Loss(dB):	≤ 0.05
Insulation resistance(M Ω)	≥ 10000
Proof Voltage(V)	2500
Conductor resistance(m Ω)	outer conductor <0.2 inner conductor <0.8

II. Mechanical Performance

Nut Torque	25N.m
(Nut)Whorl pull	1000N
Tensile force(cable-connect)	500N
Torsion(cable-connect)	5N.m

III. Material and plating

Component	Material	Plating
Inner conductor	Spring Copper	Ag 5 μ m
Outer conductor	Brass	Copper-tin-zinc 2 μ m
Tube	Copper	Copper-tin-zinc 2 μ m
Nut	Brass	Nickel 5 μ m
Gasket	Silicone Rubber	
Insulator	PTFE	

IV. Environment

Temp. range	-55 $^{\circ}$ C~+155 $^{\circ}$ C
Weather standard	IEC 60068 55 / 155/ 56
Thermal shock	US MIL-STD 202,Meth.107,Cond.B
Vibration	US MIL-STD 202,Meth.204,Cond.B
Shock	US MIL-STD 202,Meth.213,Cond.I
Waterproofing standard	IP68
ROHS Compliant	

V. Assembly: inner conductor installed and outer conductor crimped

MATL:	UNLESS OTHERWISE SPECIFIED	DFTM. K. A. M.	TIMES MICROWAVE SYSTEMS
	ALL DIMENSIONS ARE IN mm MACHINED SURFACES FINISH N/A RMS MAX. REMOVE ALL BURRS N/A MAX. BREAK MACHINE CORNERS N/A MAX. FILLET R. TOLERANCES ON DECIMALS .XX \pm N/A .XXX \pm N/A ANGLES $\pm 1^{\circ}$ FRACTIONS \pm N/A	DATE 5/23/11	
USED ON: 0-0	DO NOT SCALE DRAWING	CHKD. J. D. B.	EZ-600-716M-X 7-16 MALE FOR LMR-600 CABLE EZ/CRIMP/NO BRAID TRIM
		DATE 6/9/11	
SCALE: N/A	DWG. SIZE A	APPD. J. D. B.	SHEET 1 of 1 SD3190-2643 REV B
	CODE IDENT 68999	DATE 6/9/11	

Installation Instruction

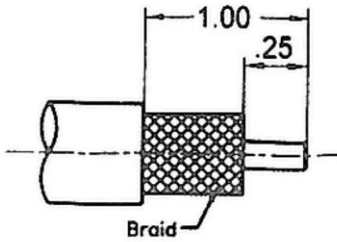

1. A. Trim cable to dimensions shown. Be careful to avoid nicking the braid
B. Remove any residual plastic from center conductor
C. Deburr center conductor using a fine file or Times DBT-U tools
D. Avoid nicking aluminum tape or center conductor

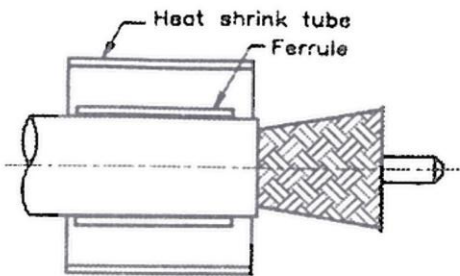

2. A. Slide crimp ferrule and heat shrink tube over the cable
B. Flare the braid

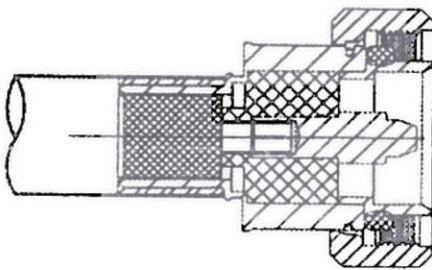

3. A. Insert Cable into connector body until dielectric is seated and center conductor is inserted fully into connector center pin.

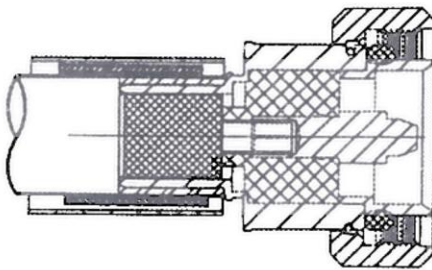

4. A. Slide crimp ferrule over braid and crimp as close to body as possible using .429" HEX crimp tooling. Pay attention to the crimp area, do not crimp rear of crimp sleeve
B. Heat shrink tube over rear of connector body and down on to cable jacket using hot air gun

LMR®-600 Flexible Low Loss Communications Coax

Ideal for...

- Jumper Assemblies in Wireless Communications Systems
- Short Antenna Feeder runs
- Any application (e.g. WLL, GPS, LMR, WLAN, WISP, WiMax, SCADA, Mobile Antennas) requiring an easily routed, low loss RF cable



• **LMR®** standard is a UV Resistant Polyethylene jacketed cable designed for 20-year service outdoor use. The bending and handling characteristics are significantly better than air-dielectric and corrugated hard-line cables.

• **LMR®-DB** is identical to standard LMR plus has the advantage of being watertight. The addition of waterproofing compound in and around the foil/braid insures continuous reliable service should the jacket be inadvertently damaged during installation or in the future.

• **LMR®-FR** is a non-halogen (non-toxic), low smoke, fire retardant cable designed for in-building runs that can be routed anywhere except air handling plenums. LMR-FR is UL/NEC & CSA rated 'CMR' and 'FT4' respectively, meets FAA FAR25 requirements and is MSHA-P for mining applications.

• **LMR®-FR-PVC** is a general-purpose indoor cable and has a UL/NEC & CSA rating of 'CMR' and 'FT4' respectively. It is less expensive than LMR-FR, however it emits toxic fumes (HCL) and greater smoke density when burned.

• **LMR®-PVC** is designed for low loss general-purpose applications and is somewhat more flexible than the standard polyethylene jacketed LMR.

• **LMR®-PVC-W** is a white-jacketed version of LMR-PVC for marine and other applications where color compatibility is desired.

• **Flexibility** and bendability are hallmarks of the LMR-600 cable design. The flexible outer conductor enables the tightest bend radius available for any cable of similar size and performance.

• **Low Loss** is another hallmark feature of LMR-600.

Size for size LMR has the lowest loss of any flexible cable and comparable loss to semirigid hard-line cables.

• **RF Shielding** is 50 dB greater than typical single shielded coax (40 dB). The multi-ply bonded foil outer conductor is rated conservatively at > 90 dB (i.e. >180 dB between two adjacent cables).

• **Weatherability:** LMR-600 cables designed for outdoor exposure incorporate the best materials for UV resistance and have life expectancy in excess of 20 years.

• **Connectors:** A wide variety of connectors are available for LMR-600 cable, including all common interface types, reverse polarity, and a choice of solder or non-solder center pins. Most LMR connectors employ crimp outer attachment using standard hex crimp sizes.

• **Cable Assemblies:** All LMR-600 cable types are available as pre-terminated cable assemblies. Refer to the section on FlexTech for further details.

Part Description				Stock	
Part Number	Application	Jacket Color	Code		
LMR-600	Outdoor	PE	Black	54003	
LMR-600-DB	Outdoor/Watertight	PE	Black	54093	
LMR-600-FR	Indoor/Outdoor Riser	CMR	FRPE	Black	54032
LMR-600-FR-PVC	Indoor/Outdoor Riser	CMR	FRPVC	Black	54074
LMR-600-PVC	General Purpose	PVC	Black	54219	
LMR-600-PVC-W	General Purpose	PVC	White	54206	

Construction Specifications			
Description	Material	In.	(mm)
Inner Conductor	Solid BCCAI	0.176	(4.47)
Dielectric	Foam PE	0.455	(11.56)
Outer Conductor	Aluminum Tape	0.461	(11.71)
Overall Braid	Tinned Copper	0.490	(12.45)
Jacket	(see table above)	0.590	(14.99)

Mechanical Specifications			
Performance Property	Units	US	(metric)
Bend Radius: installation	in. (mm)	1.50	(38.1)
Bend Radius: repeated	in. (mm)	6.0	(152.4)
Bending Moment	ft-lb (N-m)	2.75	(3.73)
Weight	lb/ft (kg/m)	0.131	(0.20)
Tensile Strength	lb (kg)	350	(158.9)
Flat Plate Crush	lb/in. (kg/mm)	60	(1.07)

Environmental Specifications		
Performance Property	°F	°C
Installation Temperature Range	-40/+185	-40/+85
Storage Temperature Range	-94/+185	-70/+85
Operating Temperature Range	-40/+185	-40/+85

Electrical Specifications			
Performance Property	Units	US	(metric)
Velocity of Propagation	%	87	
Dielectric Constant	NA	1.32	
Time Delay	nS/ft (nS/m)	1.17	(3.83)
Impedance	ohms	50	
Capacitance	pF/ft (pF/m)	23.4	(76.6)
Inductance	uH/ft (uH/m)	0.058	(0.19)
Shielding Effectiveness	dB	>90	
DC Resistance			
Inner Conductor	ohms/1000ft (/km)	0.53	(1.7)
Outer Conductor	ohms/1000ft (/km)	1.2	(3.9)
Voltage Withstand	Volts DC	4000	
Jacket Spark	Volts RMS	8000	
Peak Power	kW	40	

Attenuation vs. Frequency (typical)

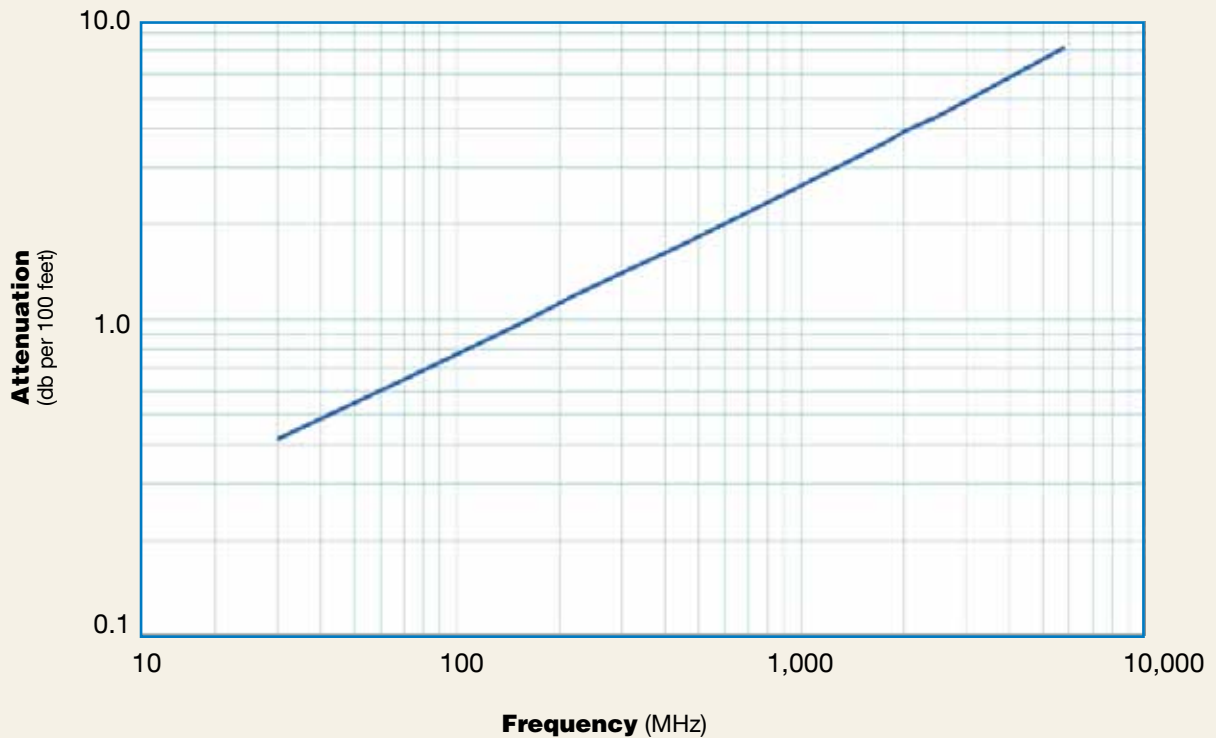

Frequency (MHz)	30	50	150	220	450	900	1500	1800	2000	2500	5800
Attenuation dB/100 ft	0.4	0.5	1.0	1.2	1.7	2.5	3.3	3.7	3.9	4.4	7.3
Attenuation dB/100 m	1.4	1.8	3.2	3.9	5.6	8.2	10.9	12.1	12.8	14.5	23.8
Avg. Power kW	5.51	4.24	2.41	1.97	1.35	0.93	0.70	0.63	0.59	0.52	0.32

Calculate Attenuation =
 $(0.075550) \cdot \sqrt{\text{FMHz}} + (0.000260) \cdot \text{FMHz}$ (interactive calculator available at http://www.timesmicrowave.com/cable_calculators)

Attenuation:
 VSWR=1.0; Ambient = +25°C (77°F)

Power:
 VSWR=1.0; Ambient = +40°C; Inner Conductor = 100°C (212°F); Sea Level; dry air; atmospheric pressure; no solar loading

LMR®-600 Flexible Low Loss Communications Coax



Connectors

Interface	Description	Part Number	Stock Code	VSWR**	Coupling Freq. (GHz)	Nut	Inner Contact Attach	Outer Contact Attach	Finish* Body /Pin	Length in (mm)	Width in (mm)	Weight lb (g)
7/8 EIA	Flange	EZ-600-78EIA	3190-1373	<1.25:1	(2.5)	NA	Spring Finger	Clamp	S/S	2.3 (58)	2.60 (66.0)	0.873 (396.0)
7-16 DIN Female	Straight Jack	TC-600-716FC	3190-375	<1.25:1	(2.5)	NA	Solder	Clamp	S/S	1.1 (28)	1.00 (25.4)	0.249 (112.9)
7-16 DIN Male	Straight Plug	EZ-600-716MH	3190-503	<1.25:1	(2.5)	Hex	Spring Finger	Crimp	S/S	2.0 (51)	1.30 (33.0)	0.254 (115.2)
	Straight Plug	TC-600-716MC	3190-502	<1.25:1	(2.5)	Hex	Solder	Clamp	S/S	2.0 (51)	1.30 (33.0)	0.347 (157.4)
	Right Angle	TC-600-716M-RA	3190-395	<1.35:1	(2.5)	Hex	Solder	Crimp	S/S	1.4 (36)	1.40 (35.6)	0.354 (160.8)
7/16 Male	Right Angle	EZ-600-716M-RA-X	3190-2546	<1.35:1	(6)	Hex	Spring Finger	Crimp	A/G	1.6 (40)	1.38 (35.0)	0.462 (210.0)
	Straight Jack	EZ-600-716F	3190-2447	<1.25:1	(6)	Hex	Spring Finger	Crimp	A/G	1.8 (45)	1.32 (33.6)	0.158 (71.7)
HN Male	Straight Plug	TC-600-HNM	3190-1429	<1.25:1	(<1)	Knurl	Solder	Clamp	S/g	2.3 (59.2)	0.88 (22.4)	0.25 (113)
LC Male	Straight Plug	TC-600-LCM	3190-1406	<1.25:1	(<1)	Hex	Solder	Clamp	N/S	3.1 (78.0)	1.62 (41.1)	1.20 (544)
N Female	Straight Jack	EZ-600-NF	3190-955	<1.25:1	(2.5)	NA	Spring Finger	Crimp	S/G	2.3 (59)	0.87 (22.1)	0.150 (68.0)
	Bulkhead Jack	EZ-600-NF-BH	3190-616	<1.25:1	(2.5)	NA	Spring Finger	Crimp	S/G	2.4 (61)	0.88 (22.4)	0.195 (88.5)
	Bulkhead Jack	TC-600-NF-BH	3190-589*	<1.25:1	(2.5)	NA	Solder	Crimp	S/G	2.4 (61)	0.88 (22.4)	0.195 (88.5)
	Bulkhead Jack	TC-600-NFC-BH	3190-466	<1.25:1	(2.5)	NA	Solder	Clamp	S/G	2.2 (56)	0.94 (23.9)	0.214 (97.1)
N Male	Straight Plug	EZ-600-NMK	3190-669	<1.25:1	(2.5)	Knurl	Spring Finger	Crimp	S/G	2.1 (53)	0.92 (23.4)	0.164 (74.4)
	Straight Plug	EZ-600-NMC-2	3190-2641	<1.25:1	(6)	Hex/Knurl	Spring Finger	Clamp	A/G	2.1 (53)	0.92 (23.4)	0.202 (91.6)
	Straight Plug	TC-600-NMC	3190-357*	<1.25:1	(2.5)	Hex	Solder	Clamp	S/G	2.1 (53)	0.92 (23.4)	0.208 (93.4)
	Straight Plug	EZ-600-NMH-X	3190-2627	<1.25:1	(8)	Hex/Knurl	Spring Finger	Crimp	A/G	2.1 (53)	0.92 (23.4)	0.164 (74.4)
	Straight Plug	TC-600-NMH-X	3190-2628	<1.25:1	(8)	Hex/Knurl	Spring Finger	Crimp	A/G	2.1 (53)	0.92 (23.4)	0.166 (75.3)
	Right Angle	EZ-600-NMH-RA-X	3190-2639	<1.35:1	(6)	Hex	Spring Finger	Crimp	A/G	2.0 (50)	1.42 (36.0)	0.224 (101.7)
	Right Angle	TC-600-NMH-RA-D	3190-2427	<1.35:1	(6)	Hex	Solder	Crimp	A/G	1.8 (46.5)	1.62 (41.2)	0.208 (93.4)
QDS Male	Straight Plug	TC-600-QDSM	3190-846	<1.25:1	(<1)	Knurl	Solder	Clamp	A/G	2.2 (55.6)	1.00 (25.4)	0.25 (113)
	Right Angle	TC-600-QDSM-RA	3190-847	<1.25:1	(<1)	Knurl	Solder	Clamp	A/G	2.4 (61.5)	1.88 (47.8)	0.35 (159)
TNC Male	Straight Plug	TC-600-TM-X	3190-2530	<1.25:1	(6)	Hex/Knurl	Solder	Crimp	A/G	2.3 (57.6)	0.75 (19.0)	0.100 (45.6)
	Straight Plug	EZ-600-TM-X	3190-2531	<1.25:1	(6)	Hex/Knurl	Spring Finger	Crimp	A/G	2.3 (57.6)	0.75 (19.0)	0.100 (45.6)
	Reverse Polarity	EZ-600-TM-RP	3190-796	<1.25:1	(2.5)	Knurl	Spring Finger	Crimp	A/G	2.2 (56)	0.87 (22.0)	0.112 (50.8)
TNC Female	Reverse Polarity	EZ-600-TF-RP	3190-797	<1.25:1	(2.5)	NA	Spring Finger	Crimp	A/G	2.3 (58)	0.87 (22.0)	0.100 (45.4)
UHF Male	Straight Plug	EZ-600-UM	3190-615	<1.25:1	(2.5)	Knurl	Spring Finger	Crimp	S/G	1.7 (43)	0.88 (22.4)	0.164 (74.4)
	STRAIGHT PLUG	TC-600-UMC	3190-213	<1.25:1	(2.5)	KNURL	SOLDER	CLAMP	S/G	1.7 (43)	0.88 (22.4)	0.198 (89.8)

Finish metals: N=Nickel, S=Silver, G=Gold, SS=Stainless Steel, A=Alballoy **VSWR spec based on 3 foot cable with a connector pair *Available in bulk pack



Install Tools

Type	Part Number	Stock Code	Description
Crimp Tool	HX-4	3190-200	Crimp Handle
Crimp Dies	Y1720	3190-203	.610" Hex Dies
Crimp Rings	CR-600	3190-831	Crimp Rings for TC/EZ-600 connectors (pkg of 10)
Strip Tool	CST-600	3192-052	Combination prep tool for LMR-600 crimp and clamp style connectors
Replacement Blades	RB-456	3190-421	Replacement Blades for Strip Tools
Deburr Tool	DBT-U	3192-001	Removes center conductor rough edges
Midspan Strip Tool	GST-600A	3190-1051	For ground strap attachment
Wrench	WR600	3190-1435	15/16" Box Wrench (2 required for EZ-600-NMC-2)
Cutting Tool	CCT-01	3190-1544	Cable end flush cut tool
Replacement Blade	RB-01	3190-1609	Replacement blade for cutting tool
Replacement Blade	RB-CST	3192-086	Replacement blade kit for all CST strip tools
Tool Kit	TK-600EZ	3190-1602	Tool kit for LMR crimp/clamp connectors (includes CCT-01, CST-600, HX-4, Y1720, Tool Pouch)



Hardware Accessories

Type	Part Number	Stock Code	Description
Ground Kit	GK-S600TT	GK-S600TT	Standard Grounding Kit (each)
Hoisting Grip	HG-600T	HG-600T	Split/Laced Type (each)
Cold Shrink	CS-A600T	CS-A600T	Cable to Antenna Junction (each)
Cold Shrink	CS-60120T	CS-60120T	LMR-600 to -1200 Junction (each)
Cold Shrink	CS-60170T	CS-60170T	LMR-600 to -1700 Junction (each)
Hanger Blocks	CB-600T	CB-600T	Dual Cable Support Block (kit of 10)
Standard Entry			
Port Cushion	SC-600T-3	SC-600T-3	Three cables (each)
Snap-In Hangers	SH-U600T	SH-U600T	Snap-In Hangers (Kit of 10)
Hanger Block Supporting Hardware			Complete Range of Supporting Hardware & Adapters Available