

## SHV Plug Right Angle Connector Crimp/ Solder Attachment for RG59B/U



### PE45847

#### Configuration

- SHV Plug Connector
- MIL-STD-348B
- 50 Ohms
- Right Angle Body Geometry
- Connector Interface Types: RG59B/U

#### Features

- Max. Operating Frequency 300 MHz
- Gold over Nickel over copper Plated Brass Contact

#### Applications

- General Purpose Test
- Custom Cable Assemblies

#### Description

Pasternack's PE45847 Right Angle, SHV, Standard, Connector is part of our full line of RF components available for same-day shipping. Our SHV plug connector operates up to a maximum frequency of 300 MHz. Its right angle body geometry allows for easier connections in tight spaces.

Our SHV plug right angle connector PE45847 datasheet specifications and drawing with dimensions are shown below in this PDF. Pasternack's broad catalog of RF, microwave and millimeter wave connectors allows designers to configure and customize their signal connections however they like. Whether the need is to provide an I/O for a board design, or simply create a custom cable assembly configuration, Pasternack has the right connector for the job. Pasternack can also expertly build your custom cable assemblies for you and ship same-day.

#### Electrical Specifications

Description	Minimum	Typical	Maximum	Units
Frequency Range	DC		300	MHz
Operating Voltage (AC)			3,500	Vrms
Dielectric Withstanding Voltage (AC)			5,000	Vrms
Inner Conductor DC Resistance			2	mOhms
Outer Conductor DC Resistance			1.5	mOhms
Insulation Resistance	50,000			MOhms
Impedance		50		Ohms

#### Mechanical Specifications

##### Size

Length	1.01 in [25.65 mm]
Width	0.57 in [14.48 mm]
Height	1.48 in [37.59 mm]
Weight	0.062 lbs [28.12 g]

## SHV Plug Right Angle Connector Crimp/ Solder Attachment for RG59B/U



**PE45847**

### Material Specifications

Description	Material	Plating
Contact	Brass	Gold over Nickel over copper
Contact Spring		Tinned Copper
Insulation	Teflon	
Body	Brass	Tinned Copper
Coupling Nut	Brass	Tinned Copper
Gasket	Silicone	
Crimp Sleeve	Brass	Tinned Copper
Washer	Brass	Tinned Copper BNC3100-4/W

### Environmental Specifications

#### Temperature

Operating Range

-65 to +165 deg C

Thermal Shock

MIL-STD-202, Method 107, Condition B

**Compliance Certifications** (see [product page](#) for current document)

### Plotted and Other Data

Notes:

SHV Plug Right Angle Connector Crimp/Solder Attachment for RG59B/U from Pasternack Enterprises has same day shipment for domestic and International orders. Our RF, microwave and millimeter wave products maintain a 99.4% availability and are part of the broadest selection in the industry.

Click the following link (or enter part number in "SEARCH" on website) to obtain additional part information including price, inventory and certifications: [SHV Plug Right Angle Connector Crimp/Solder Attachment for RG59B/U PE45847](#)

URL: <https://www.pasternack.com/shv-plug-rg59b-u-connector-pe45847-p.aspx>

The information contained within this document is accurate to the best of our knowledge and representative of the part described herein. It may be necessary to make modifications to the part and/or the documentation of the part in order to implement improvements. Pasternack Enterprises reserves the right to make such changes as required. Unless otherwise stated, all specifications are nominal. Pasternack Enterprises does not make any representation or warranty regarding the suitability of the part described herein for any particular purpose, and Pasternack Enterprises does not assume liability arising out of the use of any part or document.

# PE45847 CAD Drawing

## SHV Plug Right Angle Connector Crimp/Solder Attachment for RG59B/U

CONNECTOR (A)

FERRULE (C)

CAP (B)

**STRIPPING DIMENSIONS**

CRIMP SIZE REQUIRED  
CONTACT: SOLDER  
FERRULE: .256 [6.5] HEX CRIMP TOOL

REVISIONS

REV.	DESCRIPTION	DATE	APPROVED
A	INITIAL RELEASE	09/13/2022	AGANWANI

**ASSEMBLY INSTRUCTIONS:**

1. STRIP THE CABLE AS SHOWN. DO NOT NICK CENTER CONDUCTOR.
2. SLIDE THE FERRULE (C) OVER THE CABLE JACKET.
3. LOOSEN THE CABLE BRAID, THEN INSERT THE CENTER CONDUCTOR INTO THE CONNECTOR (A) UNTIL IT APPEARS IN THE CONTACT GROOVE (Y). THE CABLE BRAID MUST OVERLAP THE KNURLED SECTION OF THE CONNECTOR (A). SOLDER THE CENTER CONDUCTOR IN THE CONTACT GROOVE.
4. SLIDE THE FERRULE (C) OVER THE CABLE BRAID AND CRIMP IN PLACE.
5. SCREW THE CAP (B) INTO THE CONNECTOR (A).

UNLESS OTHERWISE SPECIFIED LEADING DIMENSIONS ARE INCHES DIMENSIONS IN [ ] ARE MILLIMETERS

**TOLERANCES:**

.X = ±.02 [ .51 ]	FRACTIONS ± 1/32
.XX = ±.005 [ .13 ]	ANGLES ± 1°

**CABLE LENGTH (L) TOLERANCES:**

L ≤ 12 [305] = +1 [25] / -0
12 [305] < L ≤ 60 [1524] = +2 [51] / -0
60 [1524] < L ≤ 120 [3048] = +4 [102] / -0
120 [3048] < L ≤ 300 [7620] = +6 [152] / -0
300 [7620] < L = +5%L / -0

ALL DIMENSIONS SHOWN ARE FOR REFERENCE ONLY.

**Pasternack Enterprises, Inc.**  
 P.O. Box 16759, Irvine, CA 92623.  
 Phone: 1.949.261.1920 | 1.866.727.8376  
 Fax: 1.949.261.7451  
 Website: www.pasternack.com  
 E-mail: sales@pasternack.com

THIRD-ANGLE PROJECTION

THE INFORMATION AND DESIGN IN THIS DOCUMENT IS THE PROPERTY OF PASTERNAK CORPORATION ALL RIGHTS RESERVED.

SHEET 1 OF 1

SCALE N/A

SIZE	CAGE CODE	DRAWN BY	ITEM NO.	REV
A	53919	AKRESOWSK	PE45847	A

THESE COMMODITIES, TECHNOLOGY OR SOFTWARE WERE EXPORTED FROM THE UNITED STATES IN ACCORDANCE WITH THE EXPORT ADMINISTRATION REGULATIONS. DIVERSION CONTRARY TO U.S. LAW PROHIBITED.

T-Rev.D

## SHV Plug Right Angle Connector Crimp/ Solder Attachment for RG59B/U



### PE45847

#### Configuration

- SHV Plug Connector
- MIL-STD-348B
- 50 Ohms
- Right Angle Body Geometry
- Connector Interface Types: RG59B/U

#### Features

- Max. Operating Frequency 300 MHz
- Gold over Nickel over copper Plated Brass Contact

#### Applications

- General Purpose Test
- Custom Cable Assemblies

#### Description

Pasternack's PE45847 Right Angle, SHV, Standard, Connector is part of our full line of RF components available for same-day shipping. Our SHV plug connector operates up to a maximum frequency of 300 MHz. Its right angle body geometry allows for easier connections in tight spaces.

Our SHV plug right angle connector PE45847 datasheet specifications and drawing with dimensions are shown below in this PDF. Pasternack's broad catalog of RF, microwave and millimeter wave connectors allows designers to configure and customize their signal connections however they like. Whether the need is to provide an I/O for a board design, or simply create a custom cable assembly configuration, Pasternack has the right connector for the job. Pasternack can also expertly build your custom cable assemblies for you and ship same-day.

#### Electrical Specifications

Description	Minimum	Typical	Maximum	Units
Frequency Range	DC		300	MHz
Operating Voltage (AC)			3,500	Vrms
Dielectric Withstanding Voltage (AC)			5,000	Vrms
Inner Conductor DC Resistance			2	mOhms
Outer Conductor DC Resistance			1.5	mOhms
Insulation Resistance	50,000			MOhms
Impedance		50		Ohms

#### Mechanical Specifications

##### Size

Length	1.01 in [25.65 mm]
Width	0.57 in [14.48 mm]
Height	1.48 in [37.59 mm]
Weight	0.062 lbs [28.12 g]

## SHV Plug Right Angle Connector Crimp/ Solder Attachment for RG59B/U



**PE45847**

### Material Specifications

Description	Material	Plating
Contact	Brass	Gold over Nickel over copper
Contact Spring		Tinned Copper
Insulation	Teflon	
Body	Brass	Tinned Copper
Coupling Nut	Brass	Tinned Copper
Gasket	Silicone	
Crimp Sleeve	Brass	Tinned Copper
Washer	Brass	Tinned Copper BNC3100-4/W

### Environmental Specifications

#### Temperature

Operating Range

-65 to +165 deg C

Thermal Shock

MIL-STD-202, Method 107, Condition B

**Compliance Certifications** (see [product page](#) for current document)

### Plotted and Other Data

Notes:

SHV Plug Right Angle Connector Crimp/Solder Attachment for RG59B/U from Pasternack Enterprises has same day shipment for domestic and International orders. Our RF, microwave and millimeter wave products maintain a 99.4% availability and are part of the broadest selection in the industry.

Click the following link (or enter part number in "SEARCH" on website) to obtain additional part information including price, inventory and certifications: [SHV Plug Right Angle Connector Crimp/Solder Attachment for RG59B/U PE45847](#)

URL: <https://www.pasternack.com/shv-plug-rg59b-u-connector-pe45847-p.aspx>

The information contained within this document is accurate to the best of our knowledge and representative of the part described herein. It may be necessary to make modifications to the part and/or the documentation of the part in order to implement improvements. Pasternack Enterprises reserves the right to make such changes as required. Unless otherwise stated, all specifications are nominal. Pasternack Enterprises does not make any representation or warranty regarding the suitability of the part described herein for any particular purpose, and Pasternack Enterprises does not assume liability arising out of the use of any part or document.

# PE45847 CAD Drawing

## SHV Plug Right Angle Connector Crimp/Solder Attachment for RG59B/U

CONNECTOR (A)

FERRULE (C)

CAP (B)

**STRIPPING DIMENSIONS**

CRIMP SIZE REQUIRED  
CONTACT: SOLDER  
FERRULE: .256 [6.5] HEX CRIMP TOOL

REVISIONS

REV.	DESCRIPTION	DATE	APPROVED
A	INITIAL RELEASE	09/13/2022	AGANWANI

**ASSEMBLY INSTRUCTIONS:**

1. STRIP THE CABLE AS SHOWN. DO NOT NICK CENTER CONDUCTOR.
2. SLIDE THE FERRULE (C) OVER THE CABLE JACKET.
3. LOOSEN THE CABLE BRAID, THEN INSERT THE CENTER CONDUCTOR INTO THE CONNECTOR (A) UNTIL IT APPEARS IN THE CONTACT GROOVE (Y). THE CABLE BRAID MUST OVERLAP THE KNURLED SECTION OF THE CONNECTOR (A). SOLDER THE CENTER CONDUCTOR IN THE CONTACT GROOVE.
4. SLIDE THE FERRULE (C) OVER THE CABLE BRAID AND CRIMP IN PLACE.
5. SCREW THE CAP (B) INTO THE CONNECTOR (A).

THESE COMMODITIES, TECHNOLOGY OR SOFTWARE WERE EXPORTED FROM THE UNITED STATES IN ACCORDANCE WITH THE EXPORT ADMINISTRATION REGULATIONS. DIVERSION CONTRARY TO U.S. LAW PROHIBITED.

UNLESS OTHERWISE SPECIFIED LEADING DIMENSIONS ARE INCHES DIMENSIONS IN [ ] ARE MILLIMETERS

**TOLERANCES:**

.X = ±.02 [ .51 ]	FRACTIONS ± 1/32
.XX = ±.005 [ .13 ]	ANGLES ± 1°

**CABLE LENGTH (L) TOLERANCES:**

L ≤ 12 [305]	= +1 [25] / -0
12 [305] < L ≤ 60 [1524]	= +2 [51] / -0
60 [1524] < L ≤ 120 [3048]	= +4 [102] / -0
120 [3048] < L ≤ 300 [7620]	= +6 [152] / -0
300 [7620] < L	= +5%L / -0

ALL DIMENSIONS SHOWN ARE FOR REFERENCE ONLY.

Pasternack Enterprises, Inc.  
P.O. Box 16759, Irvine, CA 92623.  
Phone: 1.949.261.1920 | 1.866.727.8376  
Fax: 1.949.261.7451  
Website: www.pasternack.com  
E-mail: sales@pasternack.com

SIZE	CAGE CODE	DRAWN BY	ITEM NO.	REV
A	53919	AKRESOWSK	PE45847	A

THIRD-ANGLE PROJECTION

THE INFORMATION AND DESIGN IN THIS DOCUMENT IS THE PROPERTY OF PASTERNAK CORPORATION ALL RIGHTS RESERVED.

SHEET 1 OF 1

SCALE N/A

T-Rev.D

## 75 Ohm Flexible RG59 Coax Cable Single Shielded with Black PVC (NC) Jacket

### RF Cables Technical Data Sheet

RG59B/U

#### Configuration

- Flexible Cable
- 1 Shield(s)

#### Electrical Specifications

Description	Minimum	Typical	Maximum	Units
Frequency Range	DC		1,000	MHz
Impedance		75.3		Ohms
Velocity of Propagation		66		%
Operating Voltage (AC)			2,300	Vrms
Nominal Capacitance		20.4 [66.93]		pF/ft [pF/m]

#### Performance by Frequency Band

Description	F1	F2	F3	F4	F5	Units
Frequency	100	200	550	800	1,000	MHz
Attenuation, Max	3.81	5.37	9.18	11.21	12.68	dB/100ft
	12.5	17.62	30.12	36.78	41.6	

#### Mechanical Specifications

Diameter	0.242 in [6.15 mm]
Weight	0.039 lbs/ft [0.06 Kg/m]

#### Construction Specifications

Description	Material and Plating	Diameter
Inner Conductor	Copper Clad Steel1	0.022 in 0.56 mm
Conductor Type	Solid	
Dielectric	PE	0.146 in 3.71 mm
First Shield	Copper Braid	0.165 in 4.19 mm

Click the following link (or enter part number in "SEARCH" on website) to obtain additional part information including price, inventory and certifications: [75 Ohm Flexible RG59 Coax Cable Single Shielded with Black PVC \(NC\) Jacket RG59B/U](#)

## 75 Ohm Flexible RG59 Coax Cable Single Shielded with Black PVC (NC) Jacket

### RF Cables Technical Data Sheet

RG59B/U

Jacket	PVC (NC), Black	0.242 in [6.15 mm]
--------	-----------------	--------------------

#### Environmental Specifications

##### Temperature

Operating Range

-25 to +70 deg C

**Compliance Certifications** (see [product page](#) for current document)

#### Plotted and Other Data

Notes:

75 Ohm Flexible RG59 Coax Cable Single Shielded with Black PVC (NC) Jacket from Pasternack Enterprises has same day shipment for domestic and International orders. Our RF, microwave and millimeter wave products maintain a 99.4% availability and are part of the broadest selection in the industry.

Click the following link (or enter part number in "SEARCH" on website) to obtain additional part information including price, inventory and certifications: [75 Ohm Flexible RG59 Coax Cable Single Shielded with Black PVC \(NC\) Jacket RG59B/U](#)

URL: <https://www.pasternack.com/flexible-0.242-rg59-75-ohm-coax-cable-pvc-jacket-rg59b-u-p.aspx>

The information contained in this document is accurate to the best of our knowledge and representative of the part described herein. It may be necessary to make modifications to the part and/or the documentation of the part, in order to implement improvements. Pasternack reserves the right to make such changes as required. Unless otherwise stated, all specifications are nominal. Pasternack does not make any representation or warranty regarding the suitability of the part described herein for any particular purpose, and Pasternack does not assume any liability arising out of the use of any part or documentation.

# RG59B/U CAD Drawing

75 Ohm Flexible RG59 Coax Cable Single Shielded with Black PVC (NC) Jacket

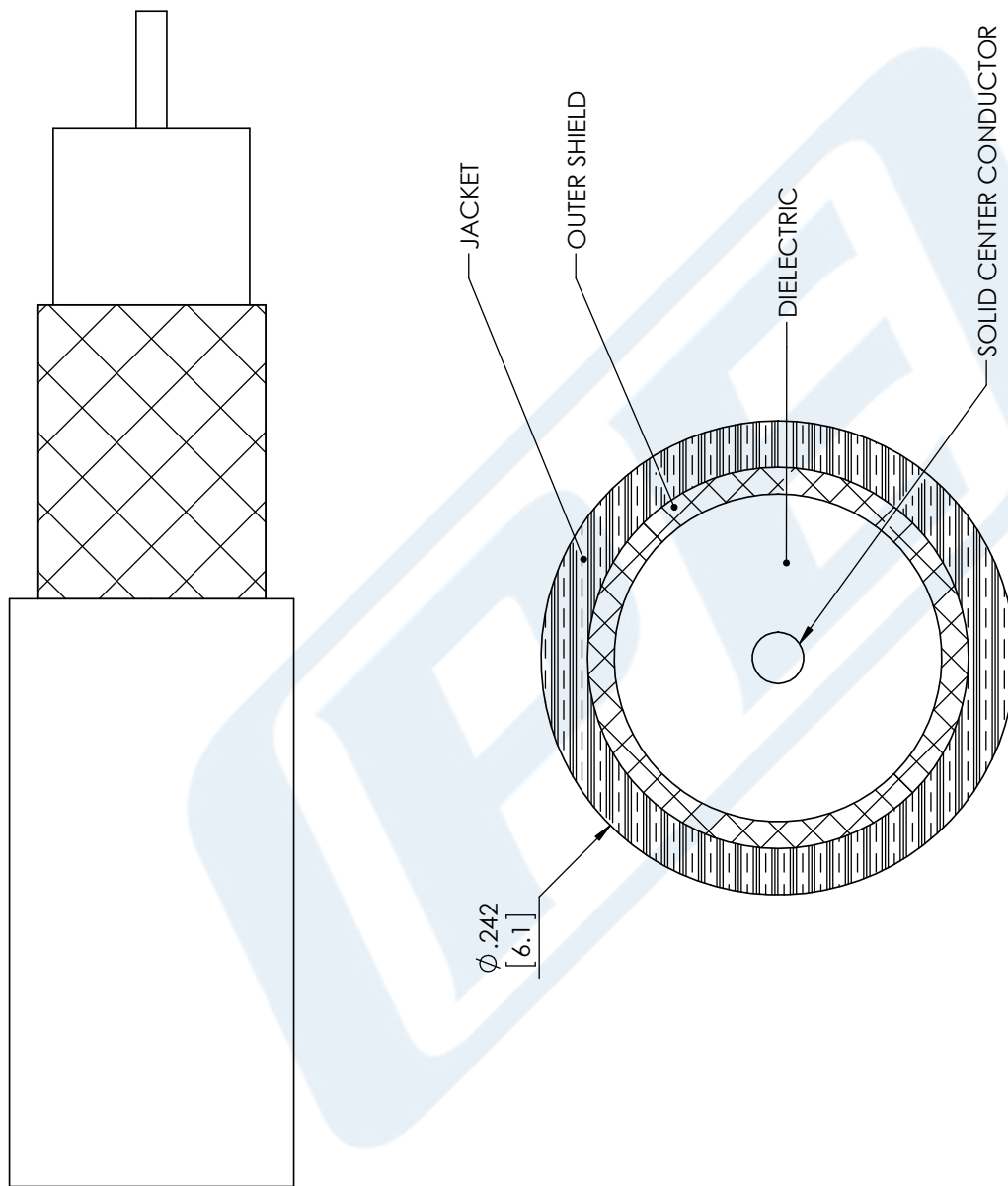

**STANDARD TOLERANCES**

.X ±0.2  
 .XX ±0.01  
 .XXX ±0.005

\*STANDARD TOLERANCES APPLY ONLY TO DIMENSIONS IN INCHES



Pasternack Enterprises, Inc.  
 P.O. Box 16759 | Irvine | CA | 92623  
**Phone:** (949) 261-1920 | **Fax:** (949) 261-7451  
**Website:** www.pasternack.com | **E-Mail:** sales@pasternack.com

DWG TITLE

RG59B/U

**CAGE CODE 53919**

NOTES:  
 1. UNLESS OTHERWISE SPECIFIED ALL DIMENSIONS ARE NOMINAL.  
 2. ALL SPECIFICATIONS ARE SUBJECT TO CHANGE WITHOUT NOTICE AT ANY TIME.  
 3. DIMENSIONS ARE IN INCHES [mm].

CAD FILE 11/28/17

SCALE N/A

SIZE A

CN2245