

**MATERIALS**

BODY	BRASS NICKEL PLATED
CONTACT	GOLD PLATED
INSULATOR	PTFE

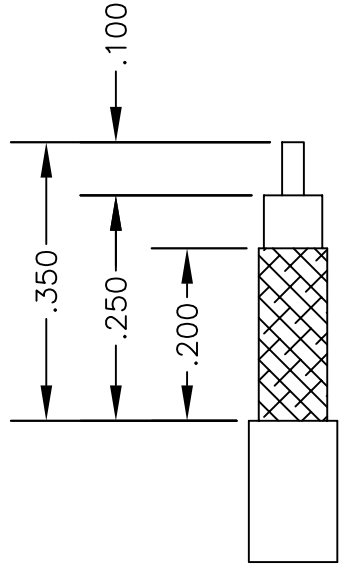
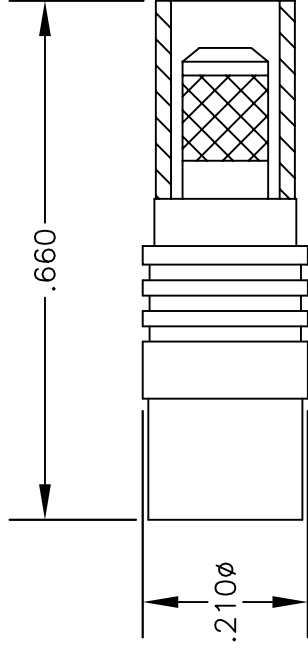

STRIPPING DIMENSIONS

CRIMP SIZE REQUIRED

CONTACT: SOLDER

FERRULE: .151" HEX CRIMP TOOL



**PASTERNAK ENTERPRISES, INC.**  
 P.O. BOX 16759, IRVINE, CA 92623  
 PHONE (949) 261-1920 FAX (949) 261-7451  
 WEB ADDRESS: [www.pasternack.com](http://www.pasternack.com)  
 E-MAIL ADDRESS: [sales@pasternack.com](mailto:sales@pasternack.com)  
**COAXIAL & FIBER OPTICS**

DWG TITLE

**PE4885**

DES. MCX JACK CRIMP ATTACHMENT FOR  
 RG188-DS & RG316-DS

SIZE A FSCM NO. 53919

CAD FILE 061802

SCALE N/A

127

NOTES:

1. UNLESS OTHERWISE SPECIFIED ALL DIMENSIONS ARE NOMINAL.
2. ALL SPECIFICATIONS ARE SUBJECT TO CHANGE WITHOUT NOTICE AT ANY TIME.

<b>MATERIALS</b>	
<b>BODY</b>	<b>BRASS NICKEL PLATED</b>
<b>CONTACT</b>	<b>GOLD PLATED</b>
<b>INSULATOR</b>	<b>PTFE</b>

ASSEMBLY PROCEDURES

1. STRIP CABLE AS SHOWN & SLIDE FERRULE (1) ONTO CABLE.
2. FLARE END OF CABLE BRAID & SLIDE METAL SPACER (2) & PTFE (3) SPACER OVER CABLE DIELECTRIC.
3. THE CONTACT (4) SHOULD BUTT AGAINST THE DIELECTRIC & PTFE SPACER. CRIMP CONTACT TO CABLE CENTER CONDUCTOR.
4. INSTALL CABLE ASSEMBLY INTO BODY SO THAT THE INNER FERRULE PORTION OF BODY SLIDES UNDER BRAID. PUSH CABLE ASSEMBLY FORWARD UNTIL CONTACT SNAPS INTO PLACE. SLIDE FERRULE OVER BRAID AND UP AGAINST CONNECTOR BODY & CRIMP.

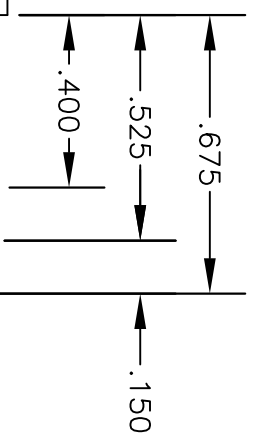
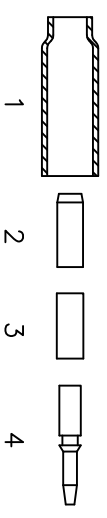

STRIPPING DIMENSIONS

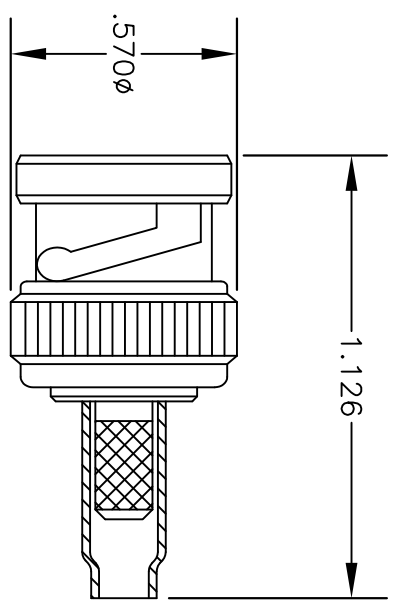

CRIMP SIZES REQUIRED

CONTACT: .068" HEX CRIMP TOOL  
 FERRULE: .178" HEX CRIMP TOOL



**PASTERNAK ENTERPRISES, INC.**  
 P.O. BOX 16759, IRVINE, CA 92623  
 PHONE (949) 261-1920 FAX (949) 261-7451  
 WEB ADDRESS: [www.pasternack.com](http://www.pasternack.com)  
 E-MAIL ADDRESS: [sales@pasternack.com](mailto:sales@pasternack.com)  
**COAXIAL & FIBER OPTICS**

DWG TITLE  
**PE4385**

DES. BNC MALE CRIMP ATTACHMENT FOR  
 RG188-DS & RG316-DS

SIZE A	FSCM NO. 53919	CAD FILE	051002	SCALE	N/A		127
--------	----------------	----------	--------	-------	-----	--	-----

NOTES:  
 1. UNLESS OTHERWISE SPECIFIED ALL DIMENSIONS ARE NOMINAL.  
 2. ALL SPECIFICATIONS ARE SUBJECT TO CHANGE WITHOUT NOTICE AT ANY TIME.

**TECHNICAL DATA SHEET**
**RG316-DS**

Flexible RG316 Coax Cable Double Shielded with Tan FEP Jacket

**Configuration**

Inner Conductor Material and Plating	Copper Clad Steel, Silver
Dielectric Type	PTFE
Shield Materials	Silver Plated Copper Braid, Silver Plated Copper Braid
Jacket Material and Color	FEP, Tan

**Electrical Specifications**

Impedance, Ohms	50
Velocity of Propagation, %	70
Maximum Operating Frequency, GHz	3
Capacitance, pF/ft [pF/m]	29.4 [96.46]
Maximum Operating Voltage, Volts	1,200

**Electrical Specifications by Frequency**
**Frequency 1**

Frequency, MHz	100
Attenuation, dB/100ft [dB/100m]	8 [26.25]

**Frequency 2**

Frequency, MHz	400
Attenuation, dB/100ft [dB/100m]	16.2 [53.15]

**Frequency 3**

Frequency, MHz	1000
Attenuation, dB/100ft [dB/100m]	26.1 [85.63]

**Frequency 4**

Frequency, GHz	3
Attenuation, dB/100ft [dB/100m]	46.7 [153.22]

**Mechanical Specifications**
**Temperature**

Operating Range, deg C	-55 to +200
------------------------	-------------

**Inner Conductor**

Number of Strands	7
Material	Copper Clad Steel
Plating	Silver
Diameter, in [mm]	0.02 [0.51]

Click the following link (or enter part number in "SEARCH" on website) to obtain additional part information including price, inventory and certifications: [Flexible RG316 Coax Cable Double Shielded with Tan FEP Jacket RG316-DS](#)

The information contained in this document is accurate to the best of our knowledge and representative of the part described herein. It may be necessary to make modifications to the part and/or the documentation of the part, in order to implement improvements. Pasternack reserves the right to make such changes as required. Unless otherwise stated, all specifications are nominal.

## TECHNICAL DATA SHEET

RG316-DS

**Dielectric:**

Type	PTFE
Diameter, in [mm]	0.06 [1.52]

**Shield:**

Number of	2
Material 1	Silver Plated Copper Braid
Material 2	Silver Plated Copper Braid
Diameter, in [mm]	0.096 [2.44]

**Jacket:**

Material	FEP
Diameter, in [mm]	0.114 [2.9]
Color	Tan
One Time Minimum Bend Radius, in [mm]	0.59 [14.99]
Weight, lbs/ft [Kg/m]	0.016 [0.02]

**Compliance Certifications** (visit [www.Pasternack.com](http://www.Pasternack.com) for current document)

RoHS Compliant	Yes
----------------	-----

**Plotted and Other Data**

Notes:	Values at 25 °C, sea level
--------	----------------------------

Flexible RG316 Coax Cable Double Shielded with Tan FEP Jacket from Pasternack Enterprises has same day shipment for domestic and International orders. Our RF, microwave and fiber optic products maintain a 99% availability and are part of the broadest selection in the industry.

Click the following link (or enter part number in "SEARCH" on website) to obtain additional part information including price, inventory and certifications: [Flexible RG316 Coax Cable Double Shielded with Tan FEP Jacket RG316-DS](#)

URL: <http://www.pasternack.com/flexible-0.114-rg316-ds-50-ohm-coax-cable-fep-jacket-rg316-ds-p.aspx>

The information contained in this document is accurate to the best of our knowledge and representative of the part described herein. It may be necessary to make modifications to the part and/or the documentation of the part, in order to implement improvements. Pasternack reserves the right to make such changes as required. Unless otherwise stated, all specifications are nominal.

# RG316-DS CAD Drawing

Flexible RG316 Coax Cable Double Shielded with Tan FEP Jacket

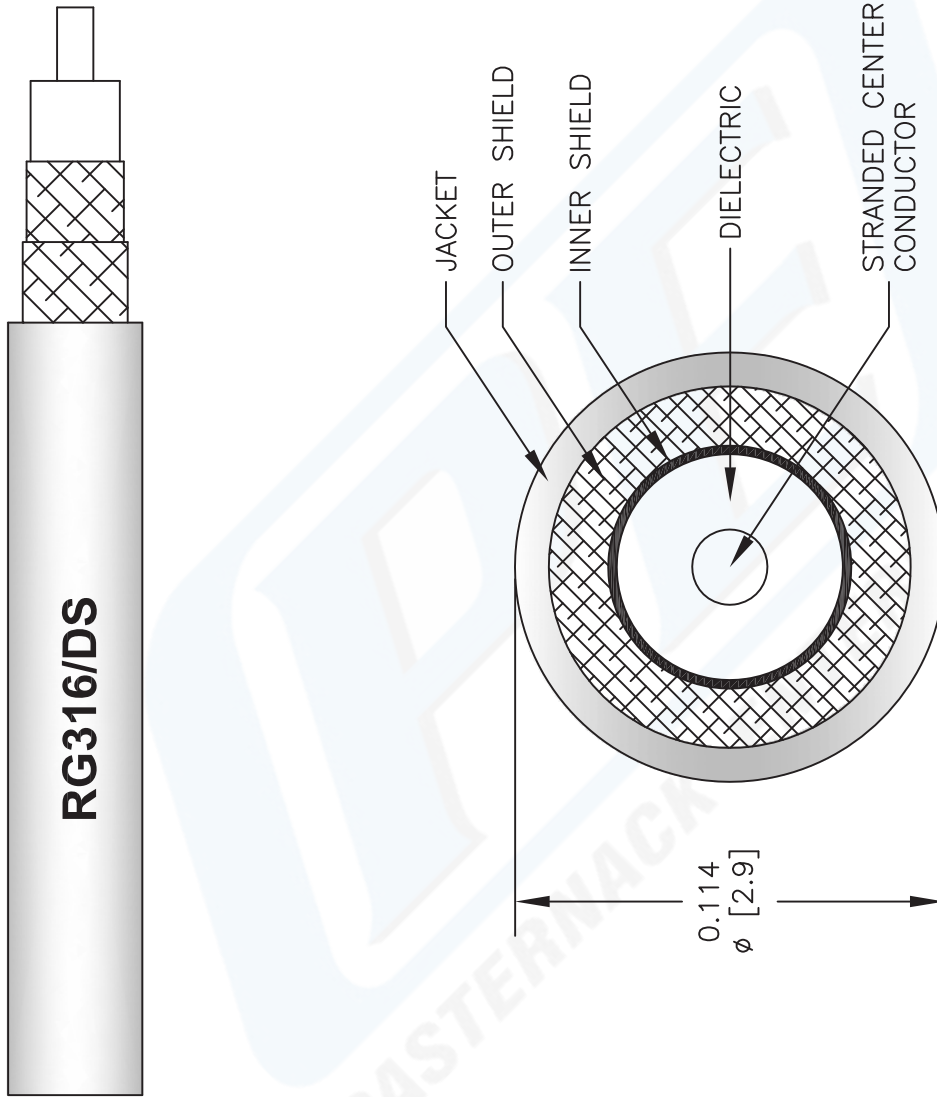

NOTES:  
 1. UNLESS OTHERWISE SPECIFIED ALL DIMENSIONS ARE NOMINAL.  
 2. ALL SPECIFICATIONS ARE SUBJECT TO CHANGE WITHOUT NOTICE AT ANY TIME.  
 3. DIMENSIONS ARE IN INCHES [mm].

DWG TITLE

**RG316-DS**

FSCM NO. 53919

2233

SIZE A

SCALE N/A

CAD FILE 041812-B



**PASTERNAK®**  
 Pasternack Enterprises, Inc.  
 P.O. Box 16759 | Irvine | CA | 92623

Phone: (949) 261-1920 | Fax: (949) 261-7451

Website: [www.pasternack.com](http://www.pasternack.com) | E-Mail: [sales@pasternack.com](mailto:sales@pasternack.com)