

**MATERIALS**

BODY	BRASS NICKEL PLATED
CONTACT	GOLD PLATED
INSULATOR	PTFE
FERRULE	GOLD PLATED

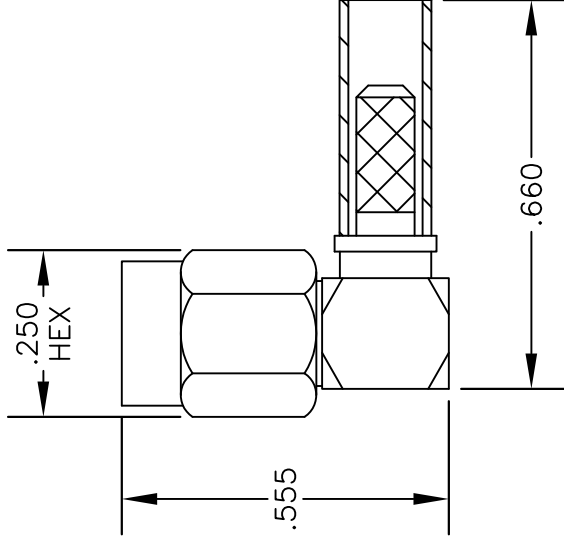

ASSEMBLY PROCEDURES

1. STRIP CABLE AS SHOWN & SLIDE FERRULE OVER CABLE.
2. INSTALL CABLE INTO BODY OF CONNECTOR AND SOFT SOLDER CENTER CONDUCTOR IN PLACE.
3. SOLDER FERRULE & PRESS CAP DOWN.

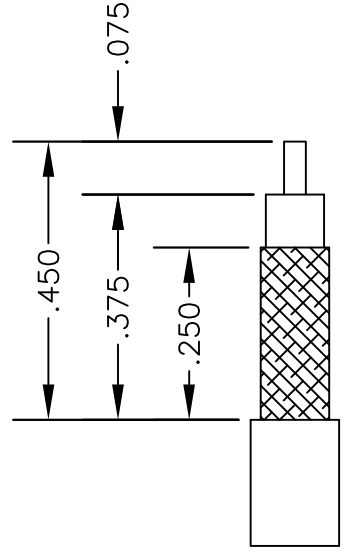

STRIPPING DIMENSIONS



**PASTERNAK ENTERPRISES, INC.**  
 P.O. BOX 16759, IRVINE, CA 92623  
 PHONE (949) 261-1920 FAX (949) 261-7451  
 WEB ADDRESS: www.pasternack.com  
 E-MAIL ADDRESS: sales@pasternack.com  
**COAXIAL & FIBER OPTICS**

DWG TITLE **PE44401** DES. SSMA MALE RIGHT ANGLE, SOLDER ATTACHMENT FOR RG174, RG188 & RG316

SIZE A	FSCM NO. 53919	CAD FILE	082803	SCALE	N/A	147
--------	----------------	----------	--------	-------	-----	-----

NOTES:

1. UNLESS OTHERWISE SPECIFIED ALL DIMENSIONS ARE NOMINAL.
2. ALL SPECIFICATIONS ARE SUBJECT TO CHANGE WITHOUT NOTICE AT ANY TIME.



SSMA Female Bulkhead Connector Crimp/Solder Attachment  
For RG174, RG316, RG188, .177 inch D Hole

RF Connectors Technical Data Sheet

PE44388

**Configuration**

- SSMA Female Connector
- MIL-C-39012
- 50 Ohms
- Straight Body Geometry
- RG174, RG316, RG188 Interface Type
- Crimp/Solder Attachment
- Bulkhead

**Mechanical Specifications**

<b>Size</b>	
Length	0.908 in [23.06 mm]
Width/Dia.	0.25 in [6.35 mm]
Weight	0.005 lbs [2.27 g]

**Material Specifications**

Description	Material	Plating
Insulation	Teflon	
Body	Brass	Nickel

**Environmental Specifications**

<b>Temperature</b>	
Operating Range	-65 to 165 deg C

**Compliance Certifications** (visit [www.Pasternack.com](http://www.Pasternack.com) for current document)

RoHS Compliant	
REACH Compliant	12/17/2014

Click the following link (or enter part number in "SEARCH" on website) to obtain additional part information including price, inventory and certifications: [SSMA Female Bulkhead Connector Crimp/Solder Attachment For RG174, RG316, RG188, .177 inch D Hole PE44388](#)



## SSMA Female Bulkhead Connector Crimp/Solder Attachment For RG174, RG316, RG188, .177 inch D Hole

### RF Connectors Technical Data Sheet

PE44388

#### Plotted and Other Data

Notes:

SSMA Female Bulkhead Connector Crimp/Solder Attachment For RG174, RG316, RG188, .177 inch D Hole from Pasternack Enterprises has same day shipment for domestic and International orders. Our RF, microwave and millimeter wave products maintain a 99% availability and are part of the broadest selection in the industry.

Click the following link (or enter part number in "SEARCH" on website) to obtain additional part information including price, inventory and certifications: [SSMA Female Bulkhead Connector Crimp/Solder Attachment For RG174, RG316, RG188, .177 inch D Hole PE44388](http://www.pasternack.com/ssma-female-standard-rg174-rg316-rg188-connector-pe44388-p.aspx)

URL: <http://www.pasternack.com/ssma-female-standard-rg174-rg316-rg188-connector-pe44388-p.aspx>

The information contained in this document is accurate to the best of our knowledge and representative of the part described herein. It may be necessary to make modifications to the part and/or the documentation of the part, in order to implement improvements. Pasternack reserves the right to make such changes as required. Unless otherwise stated, all specifications are nominal. Pasternack does not make any representation or warranty regarding the suitability of the part described herein for any particular purpose, and Pasternack does not assume any liability arising out of the use of any part or documentation.



## Flexible RG188 Coax Cable Single Shielded with White PTFE Jacket

### TECHNICAL DATA SHEET

RG188A/U

Flexible RG188 Coax Cable Single Shielded with White PTFE Jacket

#### Configuration

Inner Conductor Material and Plating	Copper Clad Steel, Silver
Dielectric Type	PTFE
Shield Materials	Silver Plated Copper Braid
Jacket Material and Color	PTFE, White

#### Electrical Specifications

Impedance, Ohms	50
Dielectric Withstanding Voltage, Vrms	2,000

#### Electrical Specifications by Frequency

##### Frequency 1

Frequency, MHz	400
Attenuation, dB/100ft [dB/100m]	20 [65.62]

#### Mechanical Specifications

##### Temperature

##### Inner Conductor

Number of Strands	7
Material	Copper Clad Steel
Plating	Silver
Diameter, in [mm]	0.02 [0.51]

##### Dielectric:

Type	PTFE
Diameter, in [mm]	0.06 [1.52]

##### Shield:

Number of	1
Material 1	Silver Plated Copper Braid
Diameter, in [mm]	0.081 [2.06]

##### Jacket:

Material	PTFE
Diameter, in [mm]	0.11 [2.79]
Color	White
Weight, lbs/ft [Kg/m]	0.011 [0.02]

Click the following link (or enter part number in "SEARCH" on website) to obtain additional part information including price, inventory and certifications: [Flexible RG188 Coax Cable Single Shielded with White PTFE Jacket RG188A/U](#)

The information contained in this document is accurate to the best of our knowledge and representative of the part described herein. It may be necessary to make modifications to the part and/or the documentation of the part, in order to implement improvements. Pasternack reserves the right to make such changes as required. Unless otherwise stated, all specifications are nominal.

Flexible RG188 Coax Cable Single  
Shielded with White PTFE Jacket

TECHNICAL DATA SHEET

RG188A/U

**Compliance Certifications** (visit [www.Pasternack.com](http://www.Pasternack.com) for current document)

RoHS Compliant

Yes

**Plotted and Other Data**

Notes:

Values at 25 °C, sea level

URL: <http://www.pasternack.com/flexible-0.110-rg188-50-ohm-coax-cable-ptfe-jacket-rg188a-u-p.aspx>

Flexible RG188 Coax Cable Single Shielded with White PTFE Jacket from Pasternack Enterprises has same day shipment for domestic and International orders. Our RF, microwave and fiber optic products maintain a 99% availability and are part of the broadest selection in the industry.

The information contained in this document is accurate to the best of our knowledge and representative of the part described herein. It may be necessary to make modifications to the part and/or the documentation of the part, in order to implement improvements. Pasternack reserves the right to make such changes as required. Unless otherwise stated, all specifications are nominal.

# RG188A/U CAD Drawing

Flexible RG188 Coax Cable Single Shielded with White PTFE Jacket

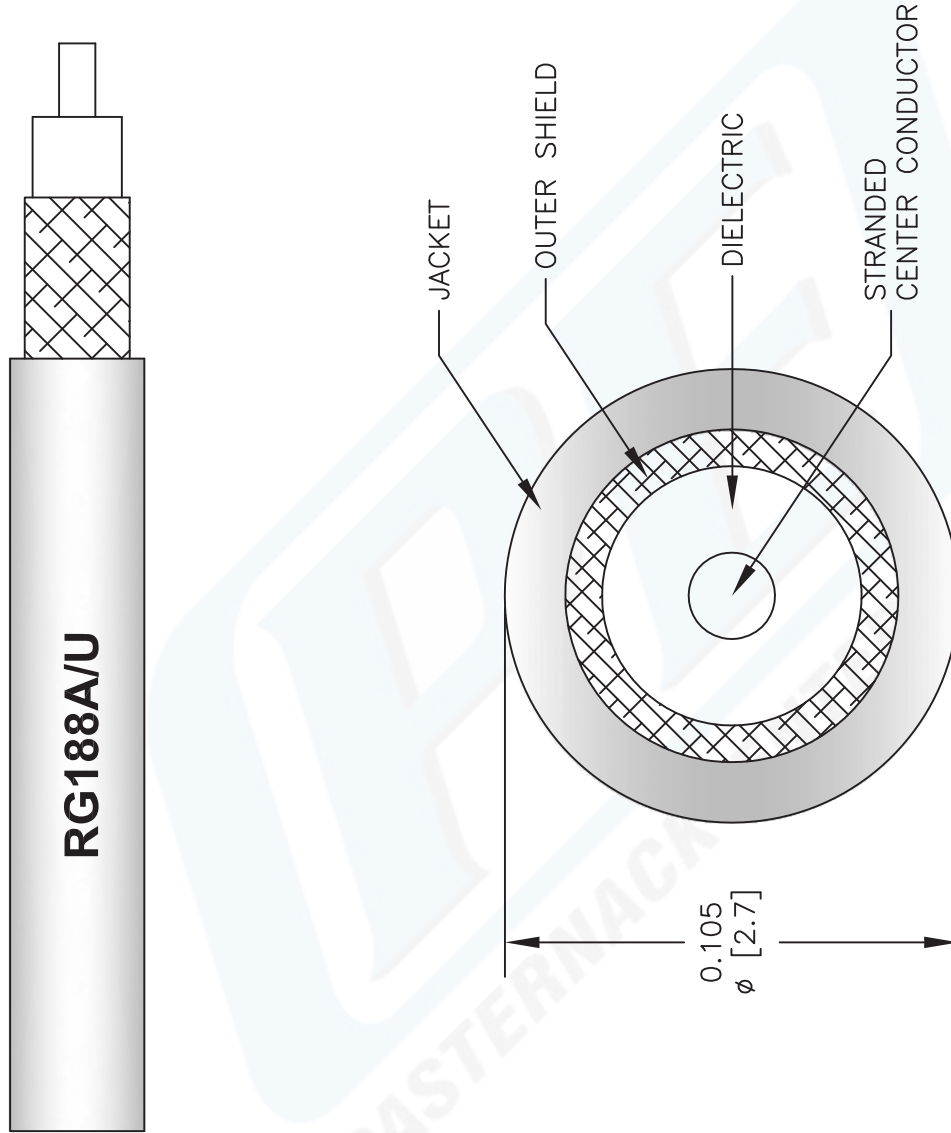

NOTES:  
1. UNLESS OTHERWISE SPECIFIED ALL DIMENSIONS ARE NOMINAL.  
2. ALL SPECIFICATIONS ARE SUBJECT TO CHANGE WITHOUT NOTICE AT ANY TIME.  
3. DIMENSIONS ARE IN INCHES [mm].

DWG TITLE

**RG188A/U**

FSCM NO. 53919

2233

SIZE A

SCALE N/A

CAD FILE 081512-C



Pasternack Enterprises, Inc.  
P.O. Box 16759 | Irvine | CA | 92623  
Phone: (949) 261-1920 | Fax: (949) 261-7451  
Website: [www.pasternack.com](http://www.pasternack.com) | E-Mail: [sales@pasternack.com](mailto:sales@pasternack.com)