



BNC Male Right Angle Connector Crimp/Solder Attachment
for RG55, RG141, RG142, RG223, RG400

RF Connectors
Technical Data Sheet

PE4345

Configuration

- BNC Male Connector
- MIL-STD-348A
- 50 Ohms
- Right Angle Body Geometry
- Connector Interface Types: RG55, RG141, RG142, RG223, RG400

Features

- Max. Operating Frequency 4 GHz
- Gold Plated Brass Contact
- 30 µin minimum contact plating

Applications

- General Purpose Test
- Custom Cable Assemblies

Description

Pasternack's PE4345 BNC male right angle connector with crimp/solder attachment for RG55, RG141, RG142, RG223 and RG400 is part of our full line of RF components available for same-day shipping. Our BNC male connector operates up to a maximum frequency of 4 GHz. Its right angle body geometry allows for easier connections in tight spaces.

Our BNC male right angle connector PE4345 datasheet specifications and drawing with dimensions are shown below in this PDF. Pasternack's broad catalog of RF, microwave and millimeter wave connectors allows designers to configure and customize their signal connections however they like. Whether the need is to provide an I/O for a board design, or simply create a custom cable assembly configuration, Pasternack has the right connector for the job. Pasternack can also expertly build your custom cable assemblies for you and ship same-day.

Electrical Specifications

Description	Minimum	Typical	Maximum	Units
Frequency Range	DC		4	GHz
Operating Voltage (AC)			500	Vrms

Performance by Frequency

Description	F1	F2	F3	F4	F5	Units
Frequency Range	DC to 3					GHz
VSWR, Max	1.35:1					

Mechanical Specifications

Size	
Length	1.35 in [34.29 mm]
Width/Dia.	0.57 in [14.48 mm]
Height	1.15 in [29.21 mm]

Click the following link (or enter part number in "SEARCH" on website) to obtain additional part information including price, inventory and certifications: [BNC Male Right Angle Connector Crimp/Solder Attachment for RG55, RG141, RG142, RG223, RG400 PE4345](#)



BNC Male Right Angle Connector Crimp/Solder Attachment
for RG55, RG141, RG142, RG223, RG400

RF Connectors
Technical Data Sheet

PE4345

Weight 0.053 lbs [24.04 g]

Material Specifications

Description	Material	Plating
Contact	Brass	Gold 30 µin minimum
Insulation	PTFE	
Body	Brass	Nickel 100 µin minimum
Coupling Nut	Brass	Nickel 100 µin minimum

Environmental Specifications

Temperature

Operating Range -65 to +165 deg C

Compliance Certifications (see [product page](#) for current document)

Plotted and Other Data

Notes:

Click the following link (or enter part number in "SEARCH" on website) to obtain additional part information including price, inventory and certifications: [BNC Male Right Angle Connector Crimp/Solder Attachment for RG55, RG141, RG142, RG223, RG400 PE4345](#)



BNC Male Right Angle Connector Crimp/Solder Attachment
for RG55, RG141, RG142, RG223, RG400

RF Connectors
Technical Data Sheet

PE4345

Assembly Instruction

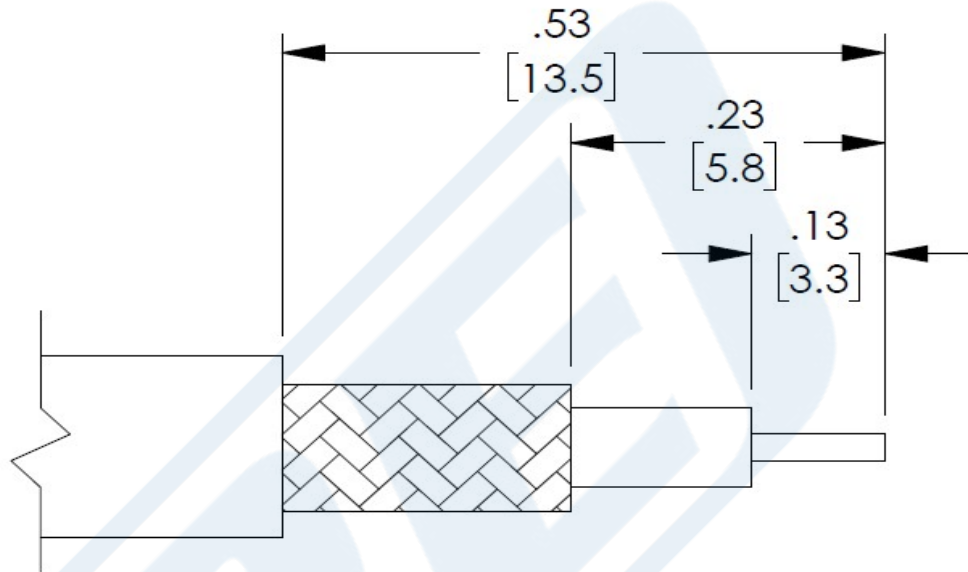

ASSEMBLY PROCEDURES

1. STRIP CABLE AS SHOWN. SLIDE FERRULE OVER CABLE AND CRIMP CONTACT TO CENTER CONDUCTOR.
2. INSTALL CABLE INTO BODY. PUSH CABLE FORWARD UNTIL CONTACT IS IN THE CORRECT POSITION.
3. SLIDE FERRULE OVER BRAID AND CRIMP.

CRIMP SIZES

- CONTACT: .068 [1.73] HEX CRIMP TOOL.
- FERRULE: .213 [5.41] HEX CRIMP TOOL.

Click the following link (or enter part number in "SEARCH" on website) to obtain additional part information including price, inventory and certifications: [BNC Male Right Angle Connector Crimp/Solder Attachment for RG55, RG141, RG142, RG223, RG400 PE4345](#)



BNC Male Right Angle Connector Crimp/Solder Attachment for RG55, RG141, RG142, RG223, RG400

RF Connectors Technical Data Sheet

PE4345

BNC Male Right Angle Connector Crimp/Solder Attachment for RG55, RG141, RG142, RG223, RG400 from Pasternack Enterprises has same day shipment for domestic and International orders. Our RF, microwave and millimeter wave products maintain a 99.4% availability and are part of the broadest selection in the industry.

Click the following link (or enter part number in "SEARCH" on website) to obtain additional part information including price, inventory and certifications: [BNC Male Right Angle Connector Crimp/Solder Attachment for RG55, RG141, RG142, RG223, RG400 PE4345](https://www.pasternack.com/bnc-male-standard-rg55-rg141-rg142-rg223-rg400-connector-pe4345-p.aspx)

URL: <https://www.pasternack.com/bnc-male-standard-rg55-rg141-rg142-rg223-rg400-connector-pe4345-p.aspx>

The information contained in this document is accurate to the best of our knowledge and representative of the part described herein. It may be necessary to make modifications to the part and/or the documentation of the part, in order to implement improvements. Pasternack reserves the right to make such changes as required. Unless otherwise stated, all specifications are nominal. Pasternack does not make any representation or warranty regarding the suitability of the part described herein for any particular purpose, and Pasternack does not assume any liability arising out of the use of any part or documentation.

PE4345 CAD Drawing

BNC Male Right Angle Connector Crimp/Solder Attachment for RG55, RG141, RG142, RG223, RG400

REVISIONS		
REV.	DESCRIPTION	DATE
B	PCR PE4345 20220518	05/26/2022
		APPROVED
		AGANWANI

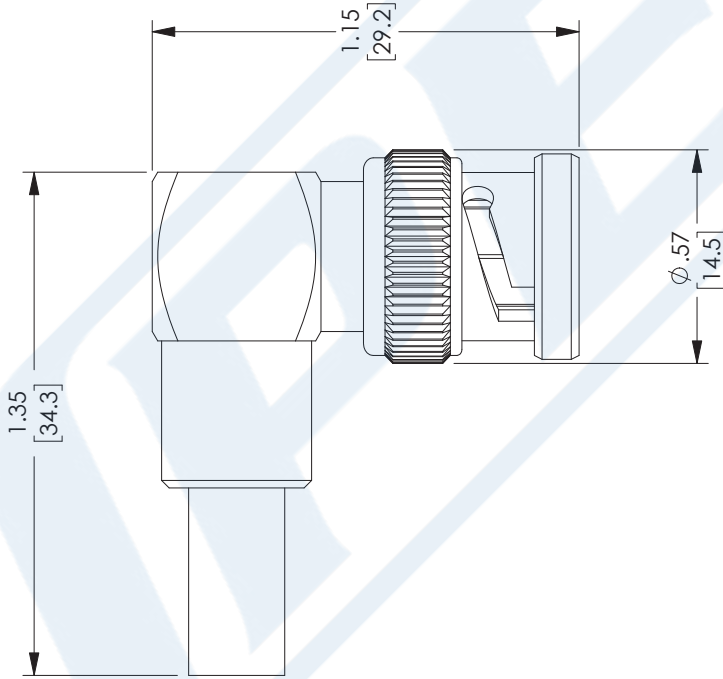

UNLESS OTHERWISE SPECIFIED LEADING DIMENSIONS ARE INCHES DIMENSIONS IN [] ARE MILLIMETERS

TOLERANCES:

X = +2 [5.08] FRACTIONS
 XX = +.02 [.51] ±.132
 .XXX = ±.005 [.13] ANGLES ± 1°

CABLE LENGTH (L) TOLERANCES:
 L ≤ 12 [305] = +1 [25] / -0
 12 [305] < L ≤ 60 [1524] = +2 [51] / -0
 60 [1524] < L ≤ 120 [3048] = +4 [102] / -0
 120 [3048] < L ≤ 300 [7620] = +6 [152] / -0
 300 [7620] < L = +5% / -0

ALL DIMENSIONS SHOWN ARE FOR REFERENCE ONLY.

PE PASTERNAK
 an INFINITI® brand

Pasternack Enterprises, Inc.
 P. O. Box 16759, Irvine, CA 92623.
 Phone: 1.949.261.1920 | 1.866.727.8376
 Fax: 1.949.261.7451
 Website: www.pasternack.com
 E-mail: sales@pasternack.com

THIRD-ANGLE PROJECTION

THE INFORMATION AND DESIGN IN THIS DOCUMENT IS THE PROPERTY OF PASTERNAK CORPORATION. ALL RIGHTS RESERVED.

SHEET 1 OF 1

SCALE N/A

REV B

ITEM NO. PE4345

DRAWN BY DFRISIELLO

CAGE CODE A 53919

SIZE A

THESE COMMODITIES, TECHNOLOGY OR SOFTWARE WERE EXPORTED FROM THE UNITED STATES IN ACCORDANCE WITH THE EXPORT ADMINISTRATION REGULATIONS. DIVERSION CONTRARY TO U.S. LAW PROHIBITED.

T-Rev-D



TNC Male Right Angle Connector Crimp/Solder Attachment for RG55, RG142, RG223, RG400

RF Connectors
Technical Data Sheet

PE4450

Configuration

- TNC Male Connector
- MIL-STD-348A
- 50 Ohms
- Right Angle Body Geometry
- Connector Interface Types: RG55, RG142, RG223, RG400

Features

- Max. Operating Frequency 3 GHz
- Good VSWR of 1.3:1
- Gold Plated Brass Contact
- 30 µin minimum contact plating

Applications

- General Purpose Test
- Custom Cable Assemblies

Description

Pasternack's PE4450 TNC male right angle connector with crimp/solder attachment for RG55, RG142, RG223 and RG400 is part of our full line of RF components available for same-day shipping. Our TNC male connector operates up to a maximum frequency of 3 GHz and offers good VSWR of 1.3:1. Its right angle body geometry allows for easier connections in tight spaces.

Our TNC male right angle connector PE4450 datasheet specifications and drawing with dimensions are shown below in this PDF. Pasternack's broad catalog of RF, microwave and millimeter wave connectors allows designers to configure and customize their signal connections however they like. Whether the need is to provide an I/O for a board design, or simply create a custom cable assembly configuration, Pasternack has the right connector for the job. Pasternack can also expertly build your custom cable assemblies for you and ship same-day.

Electrical Specifications

Description	Minimum	Typical	Maximum	Units
Frequency Range	DC		3	GHz
VSWR			1.3:1	
Operating Voltage (AC)			500	Vrms

Mechanical Specifications

Size	
Length	1.35 in [34.29 mm]
Width/Dia.	0.57 in [14.48 mm]
Height	1.14 in [28.96 mm]
Weight	0.062 lbs [28.12 g]

Click the following link (or enter part number in "SEARCH" on website) to obtain additional part information including price, inventory and certifications: [TNC Male Right Angle Connector Crimp/Solder Attachment for RG55, RG142, RG223, RG400 PE4450](#)



TNC Male Right Angle Connector Crimp/Solder Attachment for RG55, RG142, RG223, RG400

RF Connectors Technical Data Sheet

PE4450

Material Specifications

Description	Material	Plating
Contact	Brass	Gold 30 µin minimum
Insulation	PTFE	
Body	Brass	Nickel 100 µin minimum
Coupling Nut	Brass	Nickel 100 µin minimum

Environmental Specifications

Temperature

Operating Range

-65 to +165 deg C

Compliance Certifications (see [product page](#) for current document)

Plotted and Other Data

Notes:

TNC Male Right Angle Connector Crimp/Solder Attachment for RG55, RG142, RG223, RG400 from Pasternack Enterprises has same day shipment for domestic and International orders. Our RF, microwave and millimeter wave products maintain a 99.4% availability and are part of the broadest selection in the industry.

Click the following link (or enter part number in "SEARCH" on website) to obtain additional part information including price, inventory and certifications: [TNC Male Right Angle Connector Crimp/Solder Attachment for RG55, RG142, RG223, RG400 PE4450](#)

URL: <https://www.pasternack.com/tnc-male-standard-rg55-rg142-rg223-rg400-connector-pe4450-p.aspx>

The information contained in this document is accurate to the best of our knowledge and representative of the part described herein. It may be necessary to make modifications to the part and/or the documentation of the part, in order to implement improvements. Pasternack reserves the right to make such changes as required. Unless otherwise stated, all specifications are nominal. Pasternack does not make any representation or warranty regarding the suitability of the part described herein for any particular purpose, and Pasternack does not assume any liability arising out of the use of any part or documentation.

PE4450 CAD Drawing

TNC Male Right Angle Connector Crimp/Solder Attachment for RG55, RG142, RG223, RG400

REVISIONS			
REV.	DESCRIPTION	DATE	APPROVED
A	REFER TO PCR 1.4	10/16/18	J. Garcia

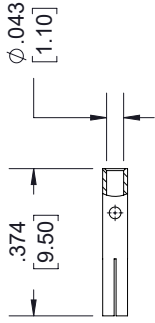

CONTACT

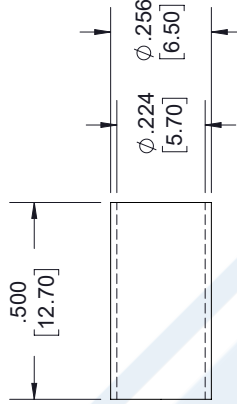

FERRULE

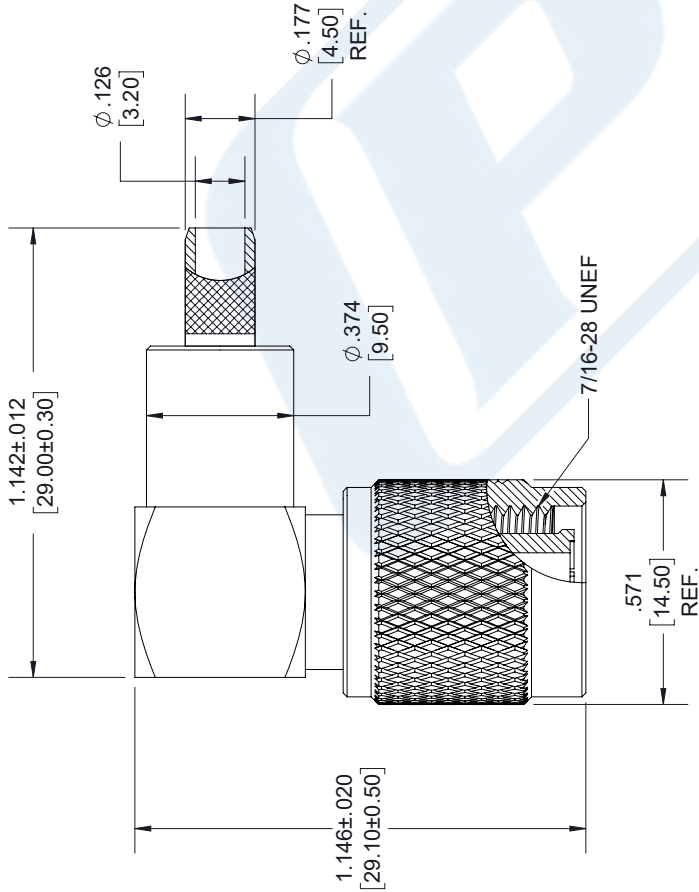
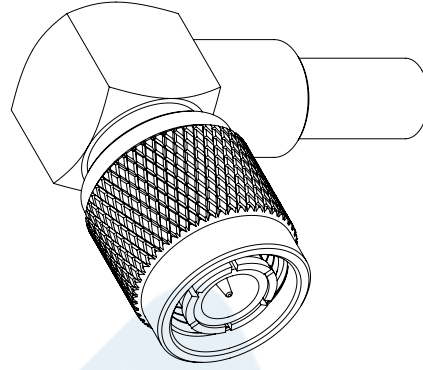

**TNC MALE
RA**

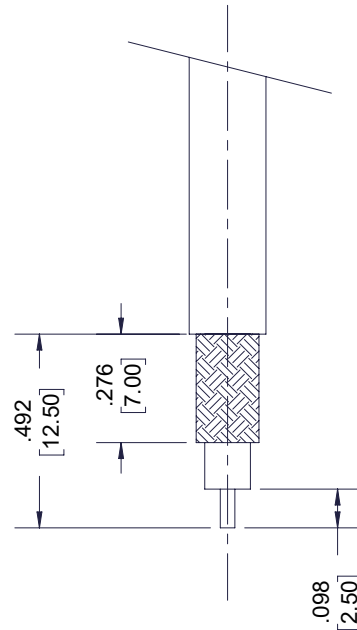

STRIPPING DIMENSION

- NOTES:
- CONTACT: .071 [1.80] HEX. CRIMP TOOL.
 - FERRULE: .221 [5.60] HEX CRIMP TOOL.

UNLESS OTHERWISE SPECIFIED LEADING DIMENSIONS ARE INCHES DIMENSIONS IN [] ARE MILLIMETERS	
TOLERANCES:	FRACTIONS
X±.2 [5.08]	±.132
.XX±.01 [0.25]	±.132
.XXX±.005 [0.13]	ANGLES ± 1°
ALL DIMENSIONS SHOWN ARE FOR REFERENCE ONLY.	
THIRD-ANGLE PROJECTION	



PASTERNAK ENTERPRISES, INC.
P.O. BOX 16759, IRVINE, CA 92623
PHONE: 949.261.1920
FAX: 949.261.7451
www.pasternack.com | e-mail: sales@pasternack.com

THE INFORMATION AND DESIGN IN THIS DOCUMENT IS THE PROPERTY OF PASTERNAK CORPORATION. ALL RIGHTS RESERVED.	
SHEET 1	OF 1
SCALE N/A	

SIZE	CAGE	DRAWN BY	PART NUMBER	REV
A	53919	7361	PE4450	A

THESE COMMODITIES, TECHNOLOGY OR SOFTWARE WERE EXPORTED FROM THE UNITED STATES IN ACCORDANCE WITH THE EXPORT ADMINISTRATION REGULATIONS. DIVERSION CONTRARY TO U.S. LAW PROHIBITED.



53 Ohm Flexible RG55 Coax Cable Double Shielded with Black PE Jacket

TECHNICAL DATA SHEET

RG55B/U

53 Ohm Flexible RG55 Coax Cable Double Shielded with Black PE Jacket

Configuration

Inner Conductor Material and Plating	Copper, Silver
Dielectric Type	PE
Shield Materials	Tinned Copper Braid, Tinned Copper Braid
Jacket Material and Color	PE, Black

Electrical Specifications

Impedance, Ohms	53
Velocity of Propagation, %	66
Maximum Operating Frequency, GHz	3
Capacitance, pF/ft [pF/m]	28.8 [94.49]

Electrical Specifications by Frequency

Frequency 1

Frequency, MHz	10
Attenuation, dB/100ft [dB/100m]	1.35 [4.43]

Frequency 2

Frequency, MHz	100
Attenuation, dB/100ft [dB/100m]	4.3 [14.11]

Frequency 3

Frequency, MHz	1000
Attenuation, dB/100ft [dB/100m]	16.5 [54.13]

Frequency 4

Frequency, GHz	3
Attenuation, dB/100ft [dB/100m]	32 [104.99]

Mechanical Specifications

Inner Conductor

Number of Strands	1
Material	Copper
Plating	Silver
Diameter, in [mm]	0.032 [0.81]

Dielectric:

Type	PE
Diameter, in [mm]	0.116 [2.95]

Click the following link (or enter part number in "SEARCH" on website) to obtain additional part information including price, inventory and certifications: [53 Ohm Flexible RG55 Coax Cable Double Shielded with Black PE Jacket RG55B/U](#)

The information contained in this document is accurate to the best of our knowledge and representative of the part described herein. It may be necessary to make modifications to the part and/or the documentation of the part, in order to implement improvements. Pasternack reserves the right to make such changes as required. Unless otherwise stated, all specifications are nominal.



53 Ohm Flexible RG55 Coax Cable Double
Shielded with Black PE Jacket

TECHNICAL DATA SHEET

RG55B/U

Shield:

Number of	2
Material 1	Tinned Copper Braid
Material 2	Tinned Copper Braid

Jacket:

Material	PE
Diameter, in [mm]	0.202 [5.13]
Color	Black
Weight, lbs/ft [Kg/m]	0.035 [0.05]

Compliance Certifications (visit www.Pasternack.com for current document)

Plotted and Other Data

Notes: Values at 25 °C, sea level

53 Ohm Flexible RG55 Coax Cable Double Shielded with Black PE Jacket from Pasternack Enterprises has same day shipment for domestic and International orders. Our RF, microwave and fiber optic products maintain a 99% availability and are part of the broadest selection in the industry.

Click the following link (or enter part number in "SEARCH" on website) to obtain additional part information including price, inventory and certifications: [53 Ohm Flexible RG55 Coax Cable Double Shielded with Black PE Jacket RG55B/U](#)

URL: <http://www.pasternack.com/flexible-0.206-rg55-53.5-ohm-coax-cable-pe-jacket-rg55b-u-p.aspx>

The information contained in this document is accurate to the best of our knowledge and representative of the part described herein. It may be necessary to make modifications to the part and/or the documentation of the part, in order to implement improvements. Pasternack reserves the right to make such changes as required. Unless otherwise stated, all specifications are nominal.

RG55B/U CAD Drawing

53 Ohm Flexible RG55 Coax Cable Double Shielded with Black PE Jacket

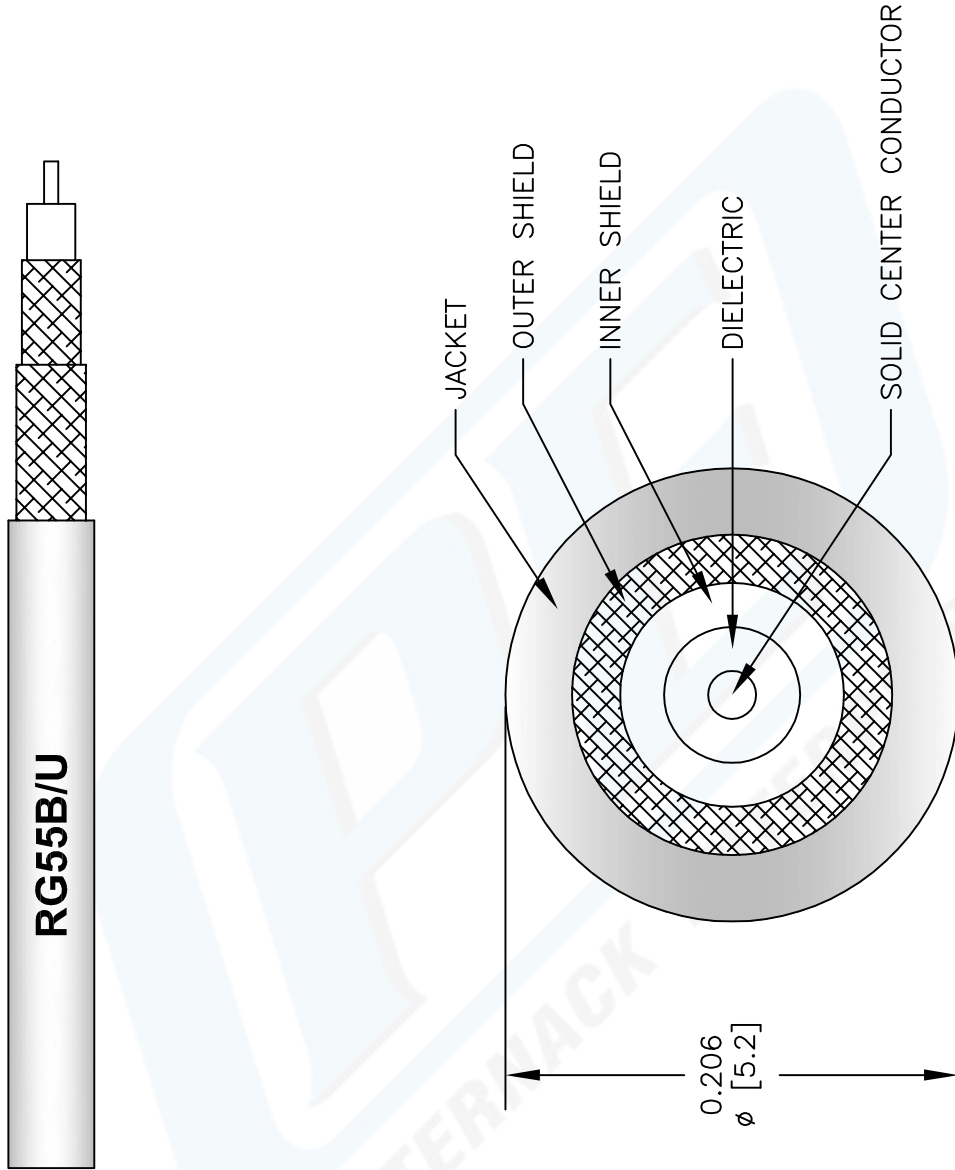

NOTES:
 1. UNLESS OTHERWISE SPECIFIED ALL DIMENSIONS ARE NOMINAL.
 2. ALL SPECIFICATIONS ARE SUBJECT TO CHANGE WITHOUT NOTICE AT ANY TIME.
 3. DIMENSIONS ARE IN INCHES [mm].

DWG TITLE
RG55B/U

147

SIZE A

SCALE N/A

CAD FILE 040113-A

REV. A | FSCM NO. 53919

PASTERNAK®
 Pasternack Enterprises, Inc.
 P.O. Box 16759 | Irvine | CA | 92623

Phone: (949) 261-1920 | Fax: (949) 261-7451

Website: www.pasternack.com | E-Mail: sales@pasternack.com