

NOTICE OF PROPRIETARY RIGHTS THIS DOCUMENT CONTAINS CONFIDENTIAL TECHNICAL DATA, INCLUDING TRADE SECRETS, PROPRIETARY TO TIMES MICROWAVE SYSTEMS. DISCLOSURE OF THIS DATA IS EXPRESSLY CONDITIONED UPON YOUR ASSENT THAT ITS USE IS LIMITED TO USE WITHIN YOUR COMPANY ONLY. ANY OTHER USE IS STRICTLY PROHIBITED WITHOUT THE PRIOR WRITTEN CONSENT OF TIMES MICROWAVE SYSTEMS.

| SYM | REVISION DESCRIPTION | DFTM | DATE | APPD | DATE |
|-----|-------------------------|----------|----------|----------|---------|
| - | RELEASED FOR PRODUCTION | J. C. L. | 8/20/03 | J. C. L. | 8/20/03 |
| A | CHANGED PER CDC #36704 | D. J. H. | 1/14/13 | J. D. B. | 1/15/13 |
| B | CHANGED PER CDC #37206 | J. D. B. | 3/226/13 | J. D. B. | 3/26/13 |



NOTES:

- ASSEMBLED CONNECTOR INTERFACE IS DESIGNED IN ACCORDANCE WITH MIL-STD-348.
- MATERIAL: BODY & HEX COUPLING NUT- CORROSION RESISTANT STEEL PER ASTM A582.
CONTACT - BERYLLIUM COPPER PER ASTM B196.
INSULATOR - TEFLON PER ASTM D1710
GASKET - SILICONE RUBBER PER ZZ-R-765
SHRINK SLEEVE - SHRINKABLE POLYOLEFIN PER MIL-I-23053/5
FERRULE - D.H.P. COPPER CDA ALLOY 122
- FINISHES: BODY & HEX COUPLING NUT - PASSIVATE PER QQ-P-35
CONTACT - GOLD PLATE PER MIL-G-45204
FERRULE - SULFAMATE NICKEL PLATE
- CONTACT PIN IS SOLDERED.
- CRIMP THE FERRULE TO .128" HEX.

| | | | | | |
|------------|---|----------------------|------------------|--|------------------------------------|
| MATERIAL: | UNLESS OTHERWISE SPECIFIED | | DFTM. J. C. L. | TIMES MICROWAVE SYSTEMS | |
| | ALL DIMENSIONS ARE IN INCHES MACHINED SURFACES FINISH N/A RMS MAX. REMOVE ALL BURRS .005 MAX. BREAK MACHINE CORNERS .005 MAX. FILLET R. TOLERANCES ON DECIMALS . XX ± .03 . XXX ± .005 ANGLES ± 1° FRACTIONS ± 1/32 | | DATE 8/20/03 | | |
| USED ON: A | | | CHKD. J. C. L. | TC-100-SM SMA MALE FOR LMR100 CABLE | |
| | | | DATE 8/20/03 | | |
| SCALE: N/A | DWG. SIZE A | DO NOT SCALE DRAWING | CODE IDENT 68999 | APPD. J. C. L. | SHEET 1 of 1 SD3190-1551 REV B |
| | | | DATE 8/20/03 | | |



TIMES MICROWAVE SYSTEMS

358 Hall Avenue/P.O. Box 5039
Wallingford, CT 06492-5039
Tel: 203-949-8400
FAX: 203-949-8423
1-800-TMS-COAX
www.timesmicrowave.com

INSTALLATION INSTRUCTIONS TC-100-SM (TIMES 3190-1551) (Cable Types: LMR-100)



- 1) A. Trim cable to dimensions shown. Slide shrink sleeve & crimp sleeve back onto cable.
B. Remove any residual plastic from the center conductor and deburr center conductor using a fine file.



- 2) A. Slide contact onto center conductor leaving a .020 gap as shown and solder to center conductor. Use minimal heat to minimize melting of foam dielectric. Inspect to be sure aluminum foil is not touching center contact.



- 3) A. Insert cable into connector until fully seated, with all braid wires on the outside of connector body and aluminum tape inside connector body.
B. Slide crimp sleeve forward and crimp as close as possible to body using a .128" hex die. Use Times HX-4 crimp tool or equivalent. Do not crimp rear of crimp sleeve.
C. Heat shrink weather seal over rear of connector body and down onto cable jacket using hot air gun.



BNC Female Connector Crimp/Solder Attachment for RG174, RG316, RG188, LMR-100, PE-B100, PE-C100, 0.100 inch

RF Connectors Technical Data Sheet

PE4079

Configuration

- BNC Female Connector
- MIL-STD-348A
- 50 Ohms
- Straight Body Geometry
- RG174, RG316, RG188, LMR-100, PE-B100, PE-C100, 0.100 inch Interface Type
- Crimp/Solder Attachment

Features

- Max. Operating Frequency 1,000 MHz
- Good VSWR of 1.5:1
- Gold Plated Brass Contact
- 30 µin minimum contact plating

Applications

- General Purpose Test
- Custom Cable Assemblies

Description

Pasternack's PE4079 BNC female connector with crimp/solder attachment for RG174, RG316, RG188, LMR-100, PE-B100, PE-C100 and 0.100 inch is part of our full line of RF components available for same-day shipping. Our BNC female connector operates up to a maximum frequency of 1,000 MHz and offers good VSWR of 1.5:1.

Our BNC female connector PE4079 datasheet specifications and drawing with dimensions are shown below in this PDF. Pasternack's broad catalog of RF, microwave and millimeter wave connectors allows designers to configure and customize their signal connections however they like. Whether the need is to provide an I/O for a board design, or simply create a custom cable assembly configuration, Pasternack has the right connector for the job. Pasternack can also expertly build your custom cable assemblies for you and ship same-day.

Electrical Specifications

| Description | Minimum | Typical | Maximum | Units |
|------------------------|---------|---------|---------|-------|
| Frequency Range | DC | | 1,000 | MHz |
| VSWR | | | 1.5:1 | |
| Operating Voltage (AC) | | | 500 | Vrms |

Mechanical Specifications

Size

| | |
|------------|---------------------|
| Length | 1.28 in [32.51 mm] |
| Width/Dia. | 0.453 in [11.51 mm] |
| Weight | 0.023 lbs [10.43 g] |

Click the following link (or enter part number in "SEARCH" on website) to obtain additional part information including price, inventory and certifications: [BNC Female Connector Crimp/Solder Attachment for RG174, RG316, RG188, LMR-100, PE-B100, PE-C100, 0.100 inch PE4079](#)



BNC Female Connector Crimp/Solder Attachment for RG174, RG316, RG188, LMR-100, PE-B100, PE-C100, 0.100 inch

RF Connectors Technical Data Sheet

PE4079

Material Specifications

| Description | Material | Plating |
|--------------|----------|---------------------------|
| Contact | Brass | Gold 30 µin minimum |
| Insulation | PTFE | |
| Body | Brass | Nickel 100 µin minimum |
| Crimp Sleeve | Brass | Nickel |

Environmental Specifications

Temperature

Operating Range

-65 to +165 deg C

Compliance Certifications (see [product page](#) for current document)

Plotted and Other Data

Notes:

BNC Female Connector Crimp/Solder Attachment for RG174, RG316, RG188, LMR-100, PE-B100, PE-C100, 0.100 inch from Pasternack Enterprises has same day shipment for domestic and International orders. Our RF, microwave and millimeter wave products maintain a 99% availability and are part of the broadest selection in the industry.

Click the following link (or enter part number in "SEARCH" on website) to obtain additional part information including price, inventory and certifications: [BNC Female Connector Crimp/Solder Attachment for RG174, RG316, RG188, LMR-100, PE-B100, PE-C100, 0.100 inch PE4079](#)

URL: <https://www.pasternack.com/bnc-female-standard-rg174-rg316-rg188-connector-pe4079-p.aspx>

The information contained in this document is accurate to the best of our knowledge and representative of the part described herein. It may be necessary to make modifications to the part and/or the documentation of the part, in order to implement improvements. Pasternack reserves the right to make such changes as required. Unless otherwise stated, all specifications are nominal. Pasternack does not make any representation or warranty regarding the suitability of the part described herein for any particular purpose, and Pasternack does not assume any liability arising out of the use of any part or documentation.

PE4079 CAD Drawing

BNC Female Connector Crimp/Solder Attachment for RG174,
RG316, RG188, LMR-100, PE-B100, PE-C100, 0.100 inch

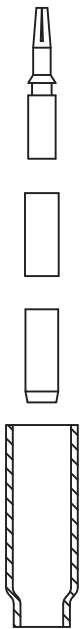

1
2
3
4

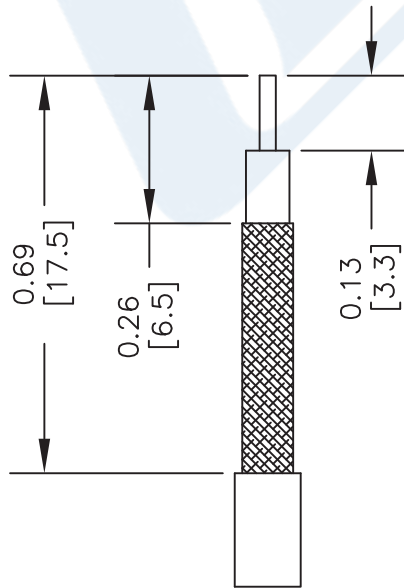

STRIPPING DIMENSIONS ASSEMBLY PROCEDURES

1. STRIP CABLE AS SHOWN & SLIDE FERRULE (1) ONTO CABLE.
2. FLARE END OF CABLE BRAID & SLIDE METAL SPACER (2) & PTFE (3) SPACER OVER CABLE DIELECTRIC.
3. THE CONTACT (4) SHOULD BUTT AGAINST THE DIELECTRIC & PTFE SPACER. CRIMP CONTACT TO CABLE CENTER CONDUCTOR.
4. INSTALL CABLE ASSEMBLY INTO BODY SO THAT THE INNER FERRULE PORTION OF BODY SLIDES UNDER BRAID. PUSH CABLE ASSEMBLY FORWARD UNTIL CONTACT SNAPS INTO PLACE. SLIDE FERRULE OVER BRAID AND UP AGAINST CONNECTOR BODY & CRIMP.

CRIMP SIZE REQUIRED

CONTACT: .068" HEX CRIMP TOOL
FERRULE: .178" HEX CRIMP TOOL

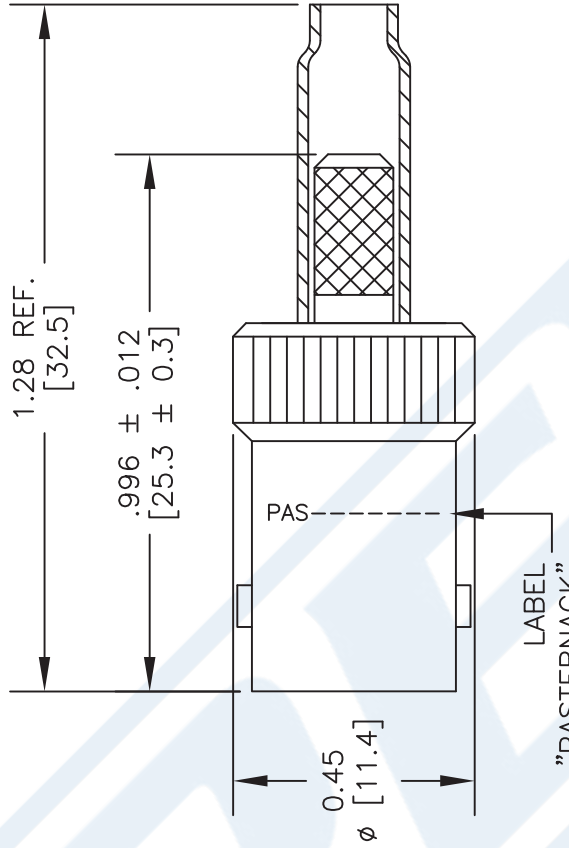

| STANDARD TOLERANCES | |
|---------------------|------------|
| .X | ± 0.2 |
| .XX | ± 0.1 |
| .XXX | ± 0.05 |

*STANDARD TOLERANCES APPLY ONLY TO DIMENSIONS IN INCHES

DWG TITLE
PE4079

NOTES:
1. UNLESS OTHERWISE SPECIFIED ALL DIMENSIONS ARE NOMINAL.
2. ALL SPECIFICATIONS ARE SUBJECT TO CHANGE WITHOUT NOTICE AT ANY TIME.
3. DIMENSIONS ARE IN INCHES [mm].
4. FITS MIL-C-17 AND EQUIVALENT CABLES.

| | | | | |
|----------------|-----------------|-----------|--------|------|
| FSCM NO. 53919 | CAD FILE 030716 | SCALE N/A | SIZE A | 2233 |
|----------------|-----------------|-----------|--------|------|

PE PASTERNAK
THE ENGINEER'S RF SOURCE
Pasternack Enterprises, Inc.
P.O. Box 16759 | Irvine | CA | 92623
Phone: (949) 261-1920 | Fax: (949) 261-7451
Website: www.pasternack.com | E-Mail: sales@pasternack.com

LMR[®]-100A Flexible Low Loss Communications Coax

Ideal for...

- Drop-in Replacement for RG-316/RG-174 (uses standard connectors)
- Jumper Assemblies in Wireless Communications Systems
- Short Antenna Feeder runs
- Any application (e.g. WLL, GPS, LMR, WLAN, WiSP, WiMax, SCADA, Mobile Antennas) requiring an easily routed, low loss RF cable

• **LMR[®]-PVC** is designed for low loss general-purpose indoor/outdoor applications and is somewhat more flexible than the standard polyethylene jacketed LMR.

• **LMR[®]-PVC-W** is a white-jacketed version of LMR-PVC for marine and other indoor/outdoor applications where color compatibility is desired.

• **Flexibility** and bendability are hallmarks of the LMR-100A cable design. The flexible outer conductor enables the tightest bend radius available for any cable of similar size and performance.

• **Low Loss** is another hallmark feature of LMR-100A. Size for size LMR has the lowest loss of any flexible cable and comparable loss to semirigid hard-line cables.

• **RF Shielding** is 50 dB greater than typical single shielded coax (40 dB). The multi-ply bonded foil outer conductor is rated conservatively at > 90 dB (i.e. >180 dB between two adjacent cables).

• **Weatherability:** LMR-100A cables designed for outdoor exposure incorporate the best materials for UV resistance and have life expectancy in excess of 20 years.

• **Connectors:** A wide variety of connectors are available for LMR-100A cable, including all common interface types, reverse polarity, and a choice of solder or non-solder center pins. Most LMR connectors employ crimp outer attachment using standard hex crimp sizes.

• **Cable Assemblies:** All LMR-100A cable types are available as pre-terminated cable assemblies. Refer to the section on FlexTech for further details.

| Part Description | | | | | Stock |
|------------------|--------------------------|--------|-------|-------|-------|
| Part Number | Application | Jacket | Color | Code | |
| LMR-100A-FR | Indoor/Outdoor Riser CMR | FRPE | Black | 54037 | |
| LMR-100A-PVC | Indoor/Outdoor | PVC | Black | 54119 | |
| LMR-100A-PVC-W | Indoor/Outdoor | PVC | White | 54200 | |

PVC = Poly Vinyl Chloride; MTO = Made to Order



| Construction Specifications | | | |
|-----------------------------|-------------------|-------|--------|
| Description | Material | In. | (mm) |
| Inner Conductor | Solid BCCS | 0.018 | (0.46) |
| Dielectric | Solid PE | 0.060 | (1.52) |
| Outer Conductor | Aluminum Tape | 0.065 | (1.65) |
| Overall Braid | Tinned Copper | 0.083 | (2.11) |
| Jacket | (see table above) | 0.110 | (2.79) |

| Mechanical Specifications | | | |
|---------------------------|----------------|--------|----------|
| Performance Property | Units | US | (metric) |
| Bend Radius: installation | in. (mm) | 0.25 | (6.4) |
| Bend Radius: repeated | in. (mm) | 1 | (25.4) |
| Bending Moment | ft-lb (N-m) | 0.1 | (0.014) |
| Weight | lb/ft (kg/m) | 0.0092 | (.014) |
| Tensile Strength | lb (kg) | 15 | (6.8) |
| Flat Plate Crush | lb/in. (kg/mm) | 10 | (0.18) |

| Environmental Specifications | | |
|--------------------------------|----------|---------|
| Performance Property | °F | °C |
| Installation Temperature Range | -40/+185 | -40/+85 |
| Storage Temperature Range | -94/+185 | -70/+85 |
| Operating Temperature Range | -40/+185 | -40/+85 |

| Electrical Specifications | | | |
|---------------------------|-------------------|-------|----------|
| Performance Property | Units | US | (metric) |
| Velocity of Propagation | % | 66 | |
| Dielectric Constant | NA | 2.30 | |
| Time Delay | nS/ft (nS/m) | 1.54 | (5.05) |
| Impedance | ohms | 50 | |
| Capacitance | pF/ft (pF/m) | 30.8 | (101.1) |
| Inductance | uH/ft (uH/m) | 0.077 | (0.25) |
| Shielding Effectiveness | dB | >90 | |
| DC Resistance | | | |
| Inner Conductor | ohms/1000ft (/km) | 81.0 | (266) |
| Outer Conductor | ohms/1000ft (/km) | 9.5 | (31.2) |
| Voltage Withstand | Volts DC | 500 | |
| Jacket Spark | Volts RMS | 2000 | |
| Peak Power | kW | 0.6 | |

Attenuation vs. Frequency (typical)



| Frequency (MHz) | 30 | 50 | 150 | 220 | 450 | 900 | 1500 | 1800 | 2000 | 2500 | 5800 |
|------------------------------|-------|-------|-------|-------|-------|-------|-------|-------|-------|-------|-------|
| Attenuation dB/100 ft | 3.9 | 5.1 | 8.9 | 10.9 | 15.8 | 22.8 | 30.1 | 33.2 | 35.2 | 39.8 | 64.1 |
| Attenuation dB/100 m | 12.9 | 16.7 | 29.4 | 35.8 | 51.9 | 74.9 | 98.7 | 109.0 | 115.5 | 130.6 | 210.3 |
| Avg. Power kW | 0.230 | 0.180 | 0.100 | 0.083 | 0.057 | 0.039 | 0.029 | 0.027 | 0.025 | 0.022 | 0.013 |

Calculate Attenuation = $(0.709140) \cdot \sqrt{\text{FMHz}} + (0.001740) \cdot \text{FMHz}$ (interactive calculator available at <http://www.timesmicrowave/telecom>)
Attenuation: VSWR=1.0 ; Ambient = +25°C (77°F) **Power:** VSWR=1.0; Ambient = +40°C; Inner Conductor = 100°C (212°F);
 Sea Level; dry air; atmospheric pressure; no solar loading



Connectors

| Interface | Description | Part Number | Stock Code | VSWR ** Freq. (GHz) | Coupling Nut | Inner Contact Attach | Outer Contact Attach | Finish* Body /Pin | Length in (mm) | Width in (mm) | Weight lb (g) |
|-----------|---------------|-------------|------------|---------------------|--------------|----------------------|----------------------|-------------------|----------------|---------------|---------------|
| SMA male | Straight Plug | TC-100-SM | 3190-1551 | <1.25:1 (<3) | Hex | Solder | Crimp | SS/G | 1.0 (25.4) | 0.32 (8.1) | 0.015 (6.8) |
| TNC male | Straight Plug | TC-100-TM | 3190-1552 | <1.25:1 (<3) | Knurl | Solder | Crimp | S/G | 1.4 (35.6) | 0.59 (15.0) | 0.045 (20.4) |

* Finish metals: N=Nickel, S=Silver, G=Gold, SS=Stainless Steel, A=Alballoy **VSWR spec based on 3 foot cable with a connector pair



Install Tools

| Type | Part Number | Stock Code | Description |
|-------------------|--------------------|------------|---|
| Crimp Tool | CT-240/200/195/100 | 3190-667 | Crimp tool for LMR-100, 195, 200 and 240 connectors |
| Cutting Tool | CCT-01 | 3190-1544 | Cable end flush cut tool |
| Replacement Blade | RB-01 | 3190-1609 | Replacement blade for cutting tool |

