



TNC Male Connector Clamp/Solder Attachment  
for RG58, RG55, RG141, RG142, RG223, RG400,  
RG303, PE-C195, PE-P195, LMR-195

## RF Connectors Technical Data Sheet

**PE4067**

### Configuration

- TNC Male Connector
- MIL-STD-348A
- 50 Ohms
- Straight Body Geometry
- Connector Interface Types: RG58, RG55, RG141, RG142, RG223, RG400, RG303, PE-C195, PE-P195, LMR-195

### Features

- Max. Operating Frequency 6 GHz
- Good VSWR of 1.5:1
- Gold Plated Brass Contact

### Applications

- General Purpose Test
- Custom Cable Assemblies

### Description

Pasternack's PE4067 TNC male connector with clamp/solder attachment for RG58, RG55, RG141, RG142, RG223, RG400, RG303, PE-C195, PE-P195 and LMR-195 is part of our full line of RF components available for same-day shipping. Our TNC male connector operates up to a maximum frequency of 6 GHz and offers good VSWR of 1.5:1.

Our TNC male connector PE4067 datasheet specifications and drawing with dimensions are shown below in this PDF. Pasternack's broad catalog of RF, microwave and millimeter wave connectors allows designers to configure and customize their signal connections however they like. Whether the need is to provide an I/O for a board design, or simply create a custom cable assembly configuration, Pasternack has the right connector for the job. Pasternack can also expertly build your custom cable assemblies for you and ship same-day.

### Electrical Specifications

Description	Minimum	Typical	Maximum	Units
Frequency Range	DC		6	GHz
VSWR			1.5:1	
Operating Voltage (AC)			500	Vrms

### Mechanical Specifications

#### Size

Length	1.06 in [26.92 mm]
Width/Dia.	0.571 in [14.50 mm]
Weight	0.046 lbs [20.87 g]

Click the following link (or enter part number in "SEARCH" on website) to obtain additional part information including price, inventory and certifications: [TNC Male Connector Clamp/Solder Attachment for RG58, RG55, RG141, RG142, RG223, RG400, RG303, PE-C195, PE-P195, LMR-195 PE4067](#)



TNC Male Connector Clamp/Solder Attachment  
for RG58, RG55, RG141, RG142, RG223, RG400,  
RG303, PE-C195, PE-P195, LMR-195

**RF Connectors**  
**Technical Data Sheet**

**PE4067**

**Material Specifications**

Description	Material	Plating
Contact	Brass	Gold
Insulation	PTFE	
Body	Brass	Nickel 100 µin minimum
Coupling Nut	Brass	Nickel 100 µin minimum

**Mechanical Specification Notes:**

When attaching the connector to the cable use a clamp torque value of 26 to 30 in-lbs [2.94 to 3.39 Nm]

**Environmental Specifications**

**Temperature**

Operating Range -65 to +165 deg C

**Compliance Certifications** (see [product page](#) for current document)

**Plotted and Other Data**

Notes:

Click the following link (or enter part number in "SEARCH" on website) to obtain additional part information including price, inventory and certifications: [TNC Male Connector Clamp/Solder Attachment for RG58, RG55, RG141, RG142, RG223, RG400, RG303, PE-C195, PE-P195, LMR-195 PE4067](#)



TNC Male Connector Clamp/Solder Attachment  
for RG58, RG55, RG141, RG142, RG223, RG400,  
RG303, PE-C195, PE-P195, LMR-195

**RF Connectors**  
**Technical Data Sheet**

**PE4067**

**Assembly Instruction**

**ASSEMBLY PROCEDURES**

1. SLIDE CLAMP NUT ①, THINNER WASHER ② & GASKET ③ OVER CABLE. STRIP CABLE AS SHOWN. DO NOT NICK BRAID WHILE CUTTING JACKET. TAPER END OF BRAID TO PERMIT ASSEMBLY OF CLAMP.

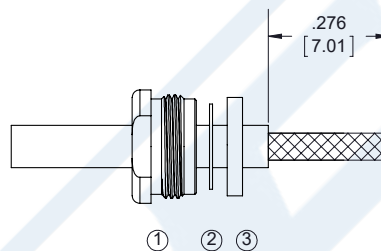

2. SLIDE BRAID CLAMP ④ OVER BRAID & SEAT AGAINST CABLE. FORM BRAID OVER CLAMP NUT. TRIM BRAID BACK TO SHOULDER. CUT DIELECTRIC & CENTER CONDUCTOR TO DIMENSION SHOWN. DO NOT NICK CENTER CONDUCTOR.

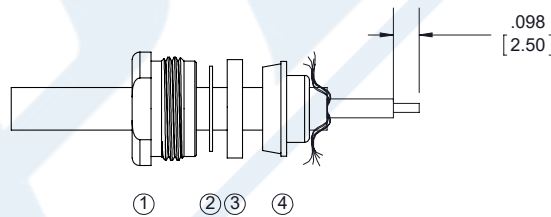

3. SOLDER CONTACT ⑤ TO CENTER CONDUCTOR. REMOVE EXCESS SOLDER. DO NOT OVER HEAT DIELECTRIC. INSERT CABLE ASSEMBLY INTO BODY ⑥ & TIGHTEN.

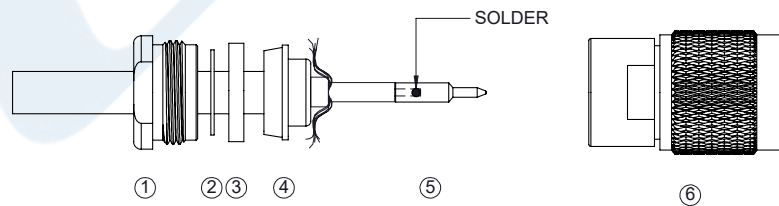

Click the following link (or enter part number in "SEARCH" on website) to obtain additional part information including price, inventory and certifications: [TNC Male Connector Clamp/Solder Attachment for RG58, RG55, RG141, RG142, RG223, RG400, RG303, PE-C195, PE-P195, LMR-195 PE4067](#)



TNC Male Connector Clamp/Solder Attachment  
for RG58, RG55, RG141, RG142, RG223, RG400,  
RG303, PE-C195, PE-P195, LMR-195

## RF Connectors Technical Data Sheet

**PE4067**

TNC Male Connector Clamp/Solder Attachment for RG58, RG55, RG141, RG142, RG223, RG400, RG303, PE-C195, PE-P195, LMR-195 from Pasternack Enterprises has same day shipment for domestic and International orders. Our RF, microwave and millimeter wave products maintain a 99.4% availability and are part of the broadest selection in the industry.

Click the following link (or enter part number in "SEARCH" on website) to obtain additional part information including price, inventory and certifications: [TNC Male Connector Clamp/Solder Attachment for RG58, RG55, RG141, RG142, RG223, RG400, RG303, PE-C195, PE-P195, LMR-195 PE4067](https://www.pasternack.com/tnc-male-standard-rg58-rg55-rg141-rg142-rg223-rg400-connector-pe4067-p.aspx)

URL: <https://www.pasternack.com/tnc-male-standard-rg58-rg55-rg141-rg142-rg223-rg400-connector-pe4067-p.aspx>

The information contained in this document is accurate to the best of our knowledge and representative of the part described herein. It may be necessary to make modifications to the part and/or the documentation of the part, in order to implement improvements. Pasternack reserves the right to make such changes as required. Unless otherwise stated, all specifications are nominal. Pasternack does not make any representation or warranty regarding the suitability of the part described herein for any particular purpose, and Pasternack does not assume any liability arising out of the use of any part or documentation.

# PE4067 CAD Drawing

TNC Male Connector Clamp/Solder Attachment for RG58, RG55, RG141, RG142, RG223, RG400, RG303, PE-C195, PE-P195, LMR-195

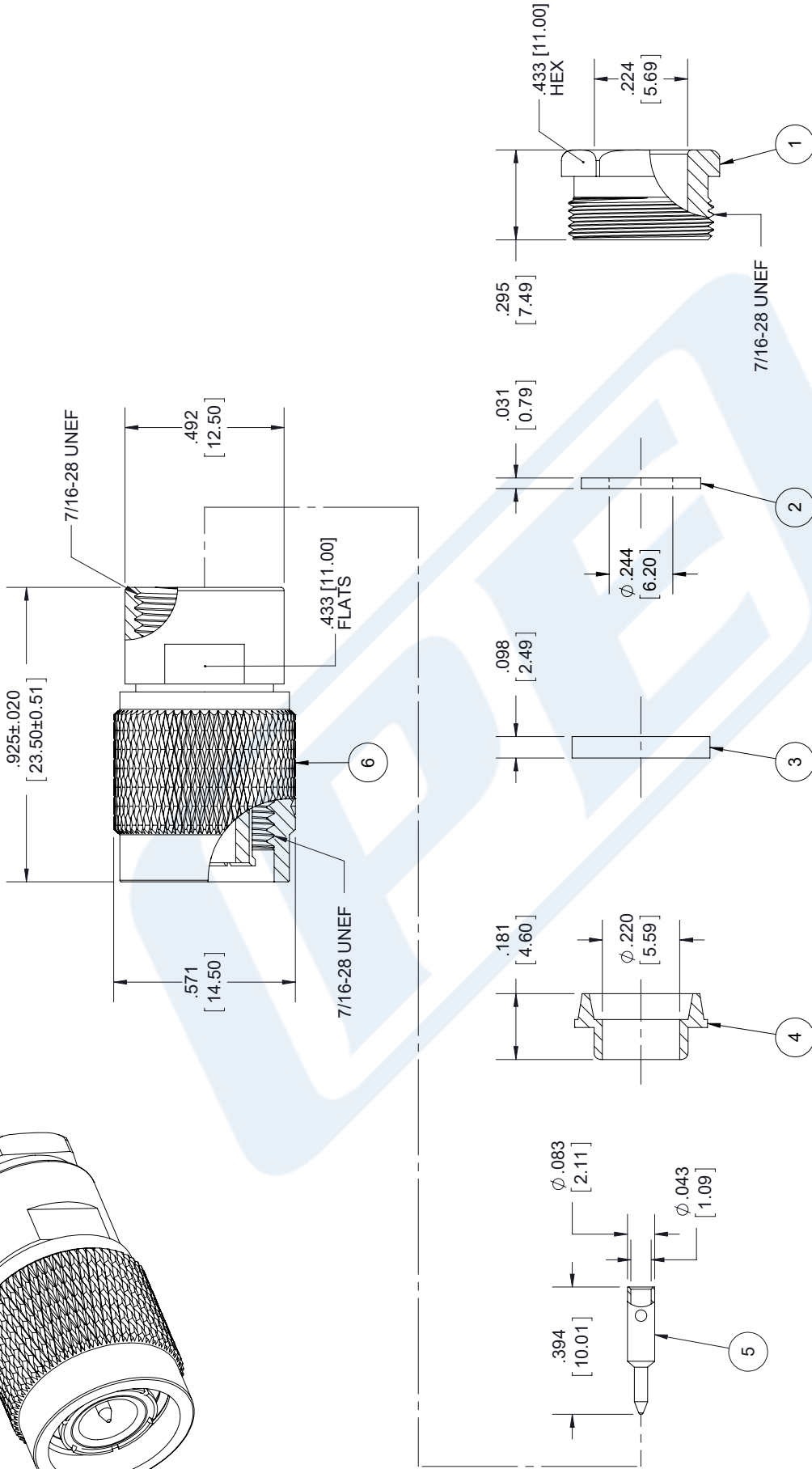
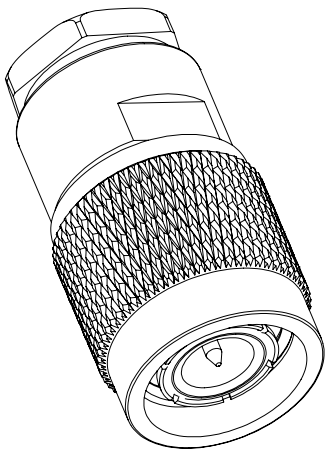

STANDARD TOLERANCES	
.X	±0.2
.XX	±0.01
.XXX	±0.005

\*STANDARD TOLERANCES APPLY ONLY TO DIMENSIONS IN INCHES



Pasternack Enterprises, Inc.  
P.O. Box 16759 | Irvine | CA | 92623

Phone: (949) 261-1920 | Fax: (949) 261-7451  
Website: www.pasternack.com | E-Mail: sales@pasternack.com

DWG TITLE  
**PE4067**

CAGE CODE **53919**

NOTES:  
1. UNLESS OTHERWISE SPECIFIED ALL DIMENSIONS ARE NOMINAL.  
2. ALL SPECIFICATIONS ARE SUBJECT TO CHANGE WITHOUT NOTICE AT ANY TIME  
3. DIMENSIONS ARE IN INCHES [mm].

CAD FILE	092817	SCALE	N/A	SIZE	A
					7361



## TNC Male Right Angle Connector Crimp/Solder Attachment for RG55, RG142, RG223, RG400

### RF Connectors Technical Data Sheet

**PE4450**

#### Configuration

- TNC Male Connector
- MIL-STD-348A
- 50 Ohms
- Right Angle Body Geometry
- Connector Interface Types: RG55, RG142, RG223, RG400

#### Features

- Max. Operating Frequency 3 GHz
- Good VSWR of 1.3:1
- Gold Plated Brass Contact
- 30 µin minimum contact plating

#### Applications

- General Purpose Test
- Custom Cable Assemblies

#### Description

Pasternack's PE4450 TNC male right angle connector with crimp/solder attachment for RG55, RG142, RG223 and RG400 is part of our full line of RF components available for same-day shipping. Our TNC male connector operates up to a maximum frequency of 3 GHz and offers good VSWR of 1.3:1. Its right angle body geometry allows for easier connections in tight spaces.

Our TNC male right angle connector PE4450 datasheet specifications and drawing with dimensions are shown below in this PDF. Pasternack's broad catalog of RF, microwave and millimeter wave connectors allows designers to configure and customize their signal connections however they like. Whether the need is to provide an I/O for a board design, or simply create a custom cable assembly configuration, Pasternack has the right connector for the job. Pasternack can also expertly build your custom cable assemblies for you and ship same-day.

#### Electrical Specifications

Description	Minimum	Typical	Maximum	Units
Frequency Range	DC		3	GHz
VSWR			1.3:1	
Operating Voltage (AC)			500	Vrms

#### Mechanical Specifications

##### Size

Length	1.35 in [34.29 mm]
Width/Dia.	0.57 in [14.48 mm]
Height	1.14 in [28.96 mm]
Weight	0.062 lbs [28.12 g]

Click the following link (or enter part number in "SEARCH" on website) to obtain additional part information including price, inventory and certifications: [TNC Male Right Angle Connector Crimp/Solder Attachment for RG55, RG142, RG223, RG400 PE4450](#)



## TNC Male Right Angle Connector Crimp/Solder Attachment for RG55, RG142, RG223, RG400

### RF Connectors Technical Data Sheet

**PE4450**

#### Material Specifications

Description	Material	Plating
Contact	Brass	Gold 30 µin minimum
Insulation	PTFE	
Body	Brass	Nickel 100 µin minimum
Coupling Nut	Brass	Nickel 100 µin minimum

#### Environmental Specifications

##### Temperature

Operating Range

-65 to +165 deg C

**Compliance Certifications** (see [product page](#) for current document)

#### Plotted and Other Data

Notes:

TNC Male Right Angle Connector Crimp/Solder Attachment for RG55, RG142, RG223, RG400 from Pasternack Enterprises has same day shipment for domestic and International orders. Our RF, microwave and millimeter wave products maintain a 99.4% availability and are part of the broadest selection in the industry.

Click the following link (or enter part number in "SEARCH" on website) to obtain additional part information including price, inventory and certifications: [TNC Male Right Angle Connector Crimp/Solder Attachment for RG55, RG142, RG223, RG400 PE4450](#)

URL: <https://www.pasternack.com/tnc-male-standard-rg55-rg142-rg223-rg400-connector-pe4450-p.aspx>

The information contained in this document is accurate to the best of our knowledge and representative of the part described herein. It may be necessary to make modifications to the part and/or the documentation of the part, in order to implement improvements. Pasternack reserves the right to make such changes as required. Unless otherwise stated, all specifications are nominal. Pasternack does not make any representation or warranty regarding the suitability of the part described herein for any particular purpose, and Pasternack does not assume any liability arising out of the use of any part or documentation.

# PE4450 CAD Drawing

## TNC Male Right Angle Connector Crimp/Solder Attachment for RG55, RG142, RG223, RG400

REVISIONS			
REV.	DESCRIPTION	DATE	APPROVED
A	REFER TO PCR 1.4	10/16/18	J. Garcia

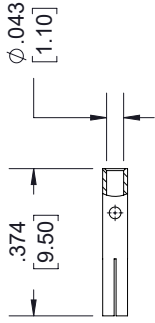

**CONTACT**

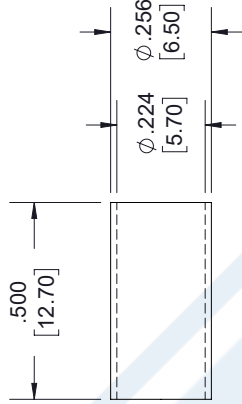

**FERRULE**

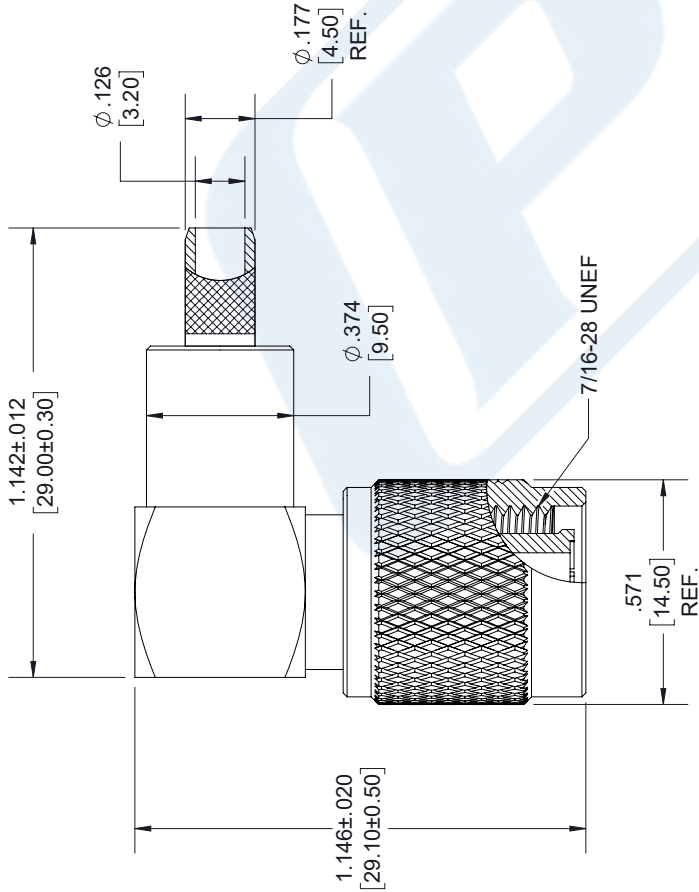
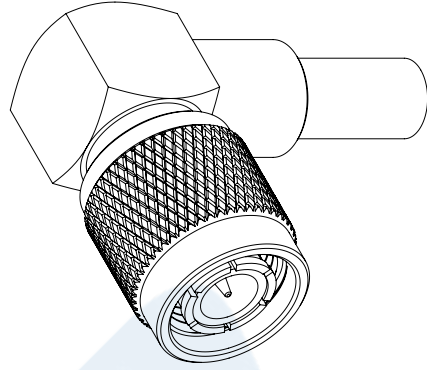

**TNC MALE  
RA**

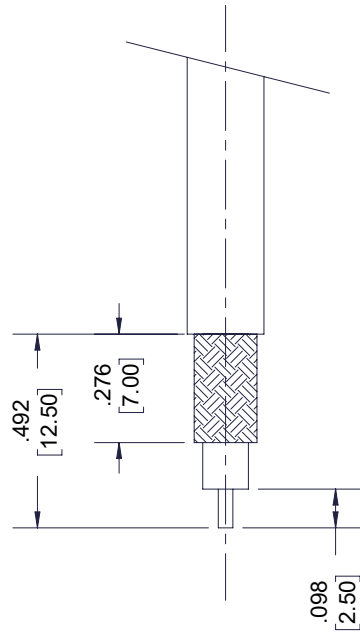

**STRIPPING DIMENSION**

**NOTES:**

- CONTACT: .071 [1.80] HEX. CRIMP TOOL.
- FERRULE: .221 [5.60] HEX CRIMP TOOL.

UNLESS OTHERWISE SPECIFIED  
LEADING DIMENSIONS ARE INCHES  
DIMENSIONS IN [ ] ARE MILLIMETERS

TOLERANCES:  
X±.2 [5.08] FRACTIONS  
XX±.01 [0.25] ±132  
XXX±.005 [0.13] ANGLES ± 1°

ALL DIMENSIONS SHOWN  
ARE FOR REFERENCE ONLY.

THIRD-ANGLE PROJECTION



PASTERNAK ENTERPRISES, INC.  
P.O. BOX 16759, IRVINE, CA 92623  
PHONE: 949.261.1920  
FAX: 949.261.7451  
www.pasternack.com | e-mail: sales@pasternack.com

THE INFORMATION AND DESIGN IN THIS DOCUMENT IS THE PROPERTY OF PASTERNAK CORPORATION. ALL RIGHTS RESERVED.	
SHEET 1	OF 1
SCALE N/A	
SIZE A	REV A

CAGE NUMBER	PART NUMBER
A 53919	PE4450
DRAWN BY	7361

THESE COMMODITIES, TECHNOLOGY OR SOFTWARE WERE EXPORTED FROM THE UNITED STATES IN ACCORDANCE WITH THE EXPORT ADMINISTRATION REGULATIONS. DIVERSION CONTRARY TO U.S. LAW PROHIBITED.

**TECHNICAL DATA SHEET**
**RG142B/U**

Flexible RG142 Coax Cable Double Shielded with Tan FEP Jacket

**Configuration**

Inner Conductor Material and Plating	Copper Clad Steel, Silver
Dielectric Type	PTFE
Shield Materials	Silver Plated Copper Braid, Silver Plated Copper Braid
Jacket Material and Color	FEP, Tan

**Electrical Specifications**

Impedance, Ohms	50
Velocity of Propagation, %	69.2
Maximum Operating Frequency, GHz	8
RF Shielding, dB	90
Capacitance, pF/ft [pF/m]	29.4 [96.46]
Maximum Operating Voltage, Volts	1,900

**Electrical Specifications by Frequency**
**Frequency 1**

Frequency, MHz	100
Attenuation, dB/100ft [dB/100m]	3.9 [12.8]

**Frequency 2**

Frequency, MHz	1000
Attenuation, dB/100ft [dB/100m]	13 [42.65]

**Frequency 3**

Frequency, GHz	3
Attenuation, dB/100ft [dB/100m]	23.8 [78.08]

**Frequency 4**

Frequency, GHz	5
Attenuation, dB/100ft [dB/100m]	36 [118.11]

**Mechanical Specifications**
**Temperature**

Operating Range, deg C	-55 to +200
------------------------	-------------

**Inner Conductor**

Number of Strands	1
Material	Copper Clad Steel
Plating	Silver
Diameter, in [mm]	0.037 [0.94]

Click the following link (or enter part number in "SEARCH" on website) to obtain additional part information including price, inventory and certifications: [Flexible RG142 Coax Cable Double Shielded with Tan FEP Jacket RG142B/U](#)

The information contained in this document is accurate to the best of our knowledge and representative of the part described herein. It may be necessary to make modifications to the part and/or the documentation of the part, in order to implement improvements. Pasternack reserves the right to make such changes as required. Unless otherwise stated, all specifications are nominal.



# TECHNICAL DATA SHEET RG142B/U

**Dielectric:**

Type	PTFE
Diameter, in [mm]	0.116 [2.95]

**Shield:**

Number of	2
Material 1	Silver Plated Copper Braid
Material 2	Silver Plated Copper Braid
Diameter, in [mm]	0.156 [3.96]

**Jacket:**

Material	FEP
Diameter, in [mm]	0.195 [4.95]
Color	Tan
One Time Minimum Bend Radius, in [mm]	0.984 [24.99]
Repeated Minimum Bend Radius, in [mm]	2 [50.8]
Weight, lbs/ft [Kg/m]	0.046 [0.07]

**Compliance Certifications** (visit [www.Pasternack.com](http://www.Pasternack.com) for current document)

RoHS Compliant	Yes
----------------	-----

**Plotted and Other Data**

Notes:	Values at 25 °C, sea level
--------	----------------------------

URL: <http://www.pasternack.com/flexible-0.195-rg142-50-ohm-coax-cable-fep-jacket-rg142b-u-p.aspx>

Flexible RG142 Coax Cable Double Shielded with Tan FEP Jacket from Pasternack Enterprises has same day shipment for domestic and International orders. Our RF, microwave and fiber optic products maintain a 99% availability and are part of the broadest selection in the industry.

The information contained in this document is accurate to the best of our knowledge and representative of the part described herein. It may be necessary to make modifications to the part and/or the documentation of the part, in order to implement improvements. Pasternack reserves the right to make such changes as required. Unless otherwise stated, all specifications are nominal.

# RG142B/U CAD Drawing

Flexible RG142 Coax Cable Double Shielded with Tan FEP Jacket



NOTES:  
 1. UNLESS OTHERWISE SPECIFIED ALL DIMENSIONS ARE NOMINAL.  
 2. ALL SPECIFICATIONS ARE SUBJECT TO CHANGE WITHOUT NOTICE AT ANY TIME.  
 3. DIMENSIONS ARE IN INCHES [mm].

DWG TITLE  
**RG142B/U**

FSCM NO. 53919

CAD FILE 022808-A

SCALE N/A

SIZE A

2233

**PE PASTERNAK®**  
 Pasternack Enterprises, Inc.  
 P.O. Box 16759 | Irvine | CA | 92623  
**Phone:** (949) 261-1920 | **Fax:** (949) 261-7451  
**Website:** www.pasternack.com | **E-Mail:** sales@pasternack.com