



7/16 DIN Male Right Angle Connector Crimp/Solder Attachment for LMR-195, LMR-195-FR, 0.195 inch, PE-C195, PE-P195

RF Connectors Technical Data Sheet

PE45046

Configuration

- 7/16 DIN Male Connector
- IEC 169-4
- 50 Ohms
- Right Angle Body Geometry
- LMR-195, LMR-195-FR, 0.195 inch, PE-C195, PE-P195 Interface Type
- Crimp/Solder Attachment
- 32 mm Hex

Features

- Max. Operating Frequency 3 GHz
- Excellent VSWR of 1.2:1
- Silver Plated Brass Contact

Applications

- General Purpose Test
- Custom Cable Assemblies

Description

Pasternack's PE45046 7/16 DIN male right angle connector with crimp/solder attachment for LMR-195, LMR-195-FR, 0.195 inch, PE-C195 and PE-P195 is part of our full line of RF components available for same-day shipping. Our 7/16 DIN male connector operates up to a maximum frequency of 3 GHz and offers excellent VSWR of 1.2:1. Its right angle body geometry allows for easier connections in tight spaces.

Our 7/16 DIN male right angle connector PE45046 datasheet specifications and drawing with dimensions are shown below in this PDF. Pasternack's broad catalog of RF, microwave and millimeter wave connectors allows designers to configure and customize their signal connections however they like. Whether the need is to provide an I/O for a board design, or simply create a custom cable assembly configuration, Pasternack has the right connector for the job. Pasternack can also expertly build your custom cable assemblies for you and ship same-day.

Electrical Specifications

Description	Minimum	Typical	Maximum	Units
Frequency Range	DC		3	GHz
VSWR			1.2:1	

Mechanical Specifications

Size	
Length	1.77 in [44.96 mm]
Width/Dia.	1.26 in [32.00 mm]
Height	1.55 in [39.37 mm]
Weight	0.11 lbs [49.9 g]

Click the following link (or enter part number in "SEARCH" on website) to obtain additional part information including price, inventory and certifications: [7/16 DIN Male Right Angle Connector Crimp/Solder Attachment for LMR-195, LMR-195-FR, 0.195 inch, PE-C195, PE-P195 PE45046](#)



7/16 DIN Male Right Angle Connector Crimp/Solder Attachment
for LMR-195, LMR-195-FR, 0.195 inch, PE-C195, PE-P195

RF Connectors Technical Data Sheet

PE45046

Material Specifications

Description	Material	Plating
Contact	Brass	Silver
Insulation	PTFE	
Body	Brass	Tri-Metal
Coupling Nut	Brass	Tri-Metal

Compliance Certifications (see [product page](#) for current document)

Plotted and Other Data

Notes:

7/16 DIN Male Right Angle Connector Crimp/Solder Attachment for LMR-195, LMR-195-FR, 0.195 inch, PE-C195, PE-P195 from Pasternack Enterprises has same day shipment for domestic and International orders. Our RF, microwave and millimeter wave products maintain a 99% availability and are part of the broadest selection in the industry.

Click the following link (or enter part number in "SEARCH" on website) to obtain additional part information including price, inventory and certifications: [7/16 DIN Male Right Angle Connector Crimp/Solder Attachment for LMR-195, LMR-195-FR, 0.195 inch, PE-C195, PE-P195 PE45046](#)

URL: <https://www.pasternack.com/7-16-male-lmr-195-pe-c195-pe-p195-connector-pe45046-p.aspx>

The information contained in this document is accurate to the best of our knowledge and representative of the part described herein. It may be necessary to make modifications to the part and/or the documentation of the part, in order to implement improvements. Pasternack reserves the right to make such changes as required. Unless otherwise stated, all specifications are nominal. Pasternack does not make any representation or warranty regarding the suitability of the part described herein for any particular purpose, and Pasternack does not assume any liability arising out of the use of any part or documentation.

PE45046 CAD Drawing

7/16 DIN Male Right Angle Connector Crimp/Solder Attachment for LMR-195, LMR-195-FR, 0.195 inch, PE-C195, PE-P195

ASSEMBLY PROCEDURES

1. STRIP CABLE AS SHOWN. SLIDE FERRULE OVER CABLE.

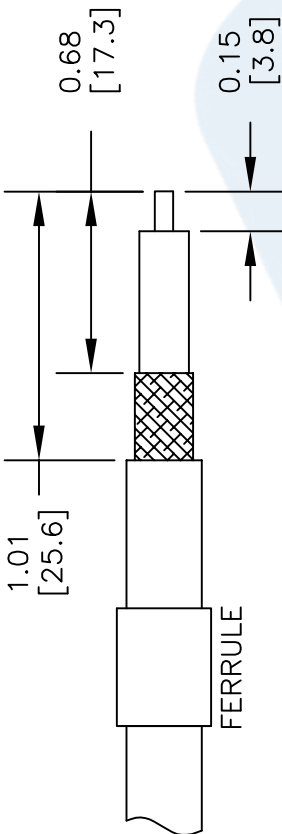

2. FLAIR BRAID AND INSERT THE STRIPPED CABLE INTO BODY AND POSITION THE CENTER CONDUCTOR IN THE SLOT OF THE CENTER PIN.

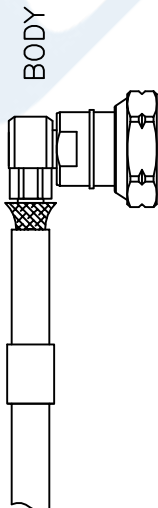

3. SLIDE FERRULE OVER BRAID UP TO THE CONNECTOR BODY AND CRIMP AS CLOSE TO THE CONNECTOR BODY AS POSSIBLE USING A .213" HEX CRIMP TOOL.

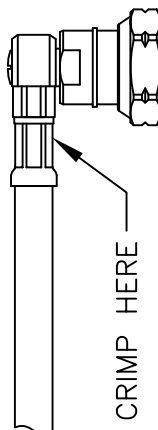

4. SOLDER THE CENTER CONDUCTOR OF THE CABLE TO THE CENTER PIN. TIGHTEN DOWN THE CAP INTO THE REAR APERTURE OF THE BO



CRIMP SIZE REQUIRED

CONTACT: SOLDER
FERRULE: .213" HEX CRIMP TOOL

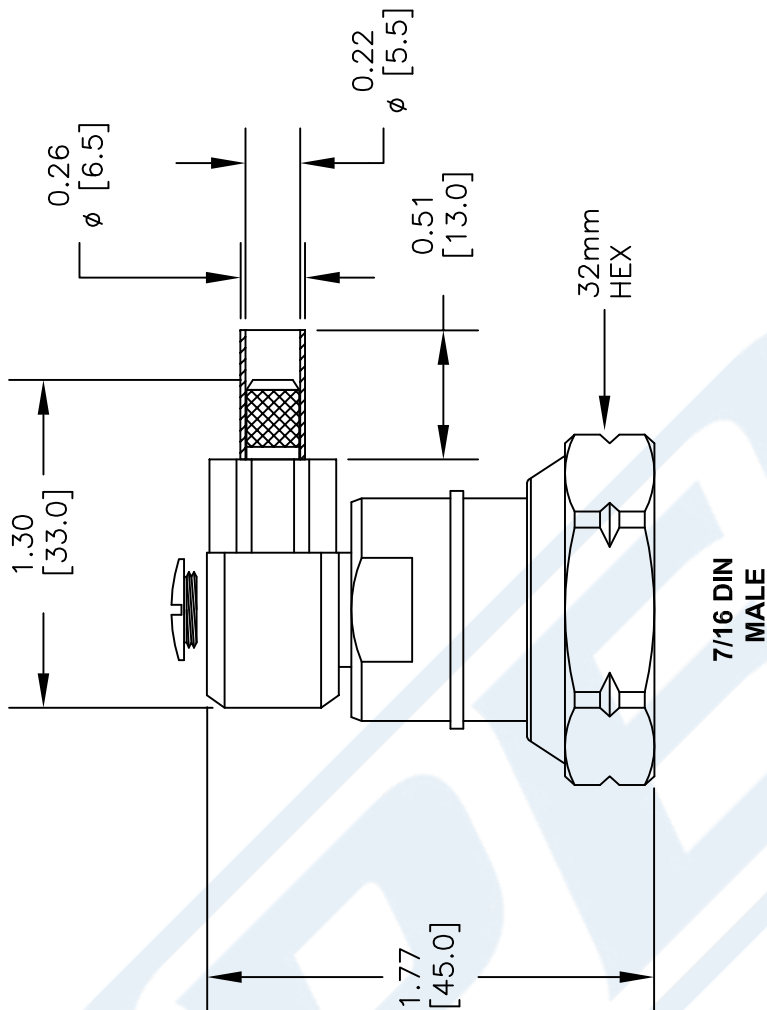

DWG TITLE

PE45046

NOTES:
1. UNLESS OTHERWISE SPECIFIED ALL DIMENSIONS ARE NOMINAL.
2. ALL SPECIFICATIONS ARE SUBJECT TO CHANGE WITHOUT NOTICE AT ANY TIME.
3. DIMENSIONS ARE IN INCHES [mm].

PE PASTERNAK
THE ENGINEER'S RF SOURCE
Pasternack Enterprises, Inc.
P.O. Box 16759 | Irvine | CA | 92623
Phone: (949) 261-1920 | Fax: (949) 261-7451
Website: www.pasternack.com | E-Mail: sales@pasternack.com

FSCM NO. 53919

CAD FILE 100214

SCALE N/A

SIZE A

150

NOTICE OF PROPRIETARY RIGHTS THIS DOCUMENT CONTAINS CONFIDENTIAL TECHNICAL DATA, INCLUDING TRADE SECRETS, PROPRIETARY TO TIMES MICROWAVE SYSTEMS. DISCLOSURE OF THIS DATA IS EXPRESSLY CONDITIONED UPON YOUR ASSENT THAT ITS USE IS LIMITED TO USE WITHIN YOUR COMPANY ONLY. ANY OTHER USE IS STRICTLY PROHIBITED WITHOUT THE PRIOR WRITTEN CONSENT OF TIMES MICROWAVE SYSTEMS.

SYM	REVISION DESCRIPTION	DFTM	DATE	APPD	DATE
A	RELEASED FOR PRODUCTION	N. N. N	1/15/14	J. D. B.	1/15/14

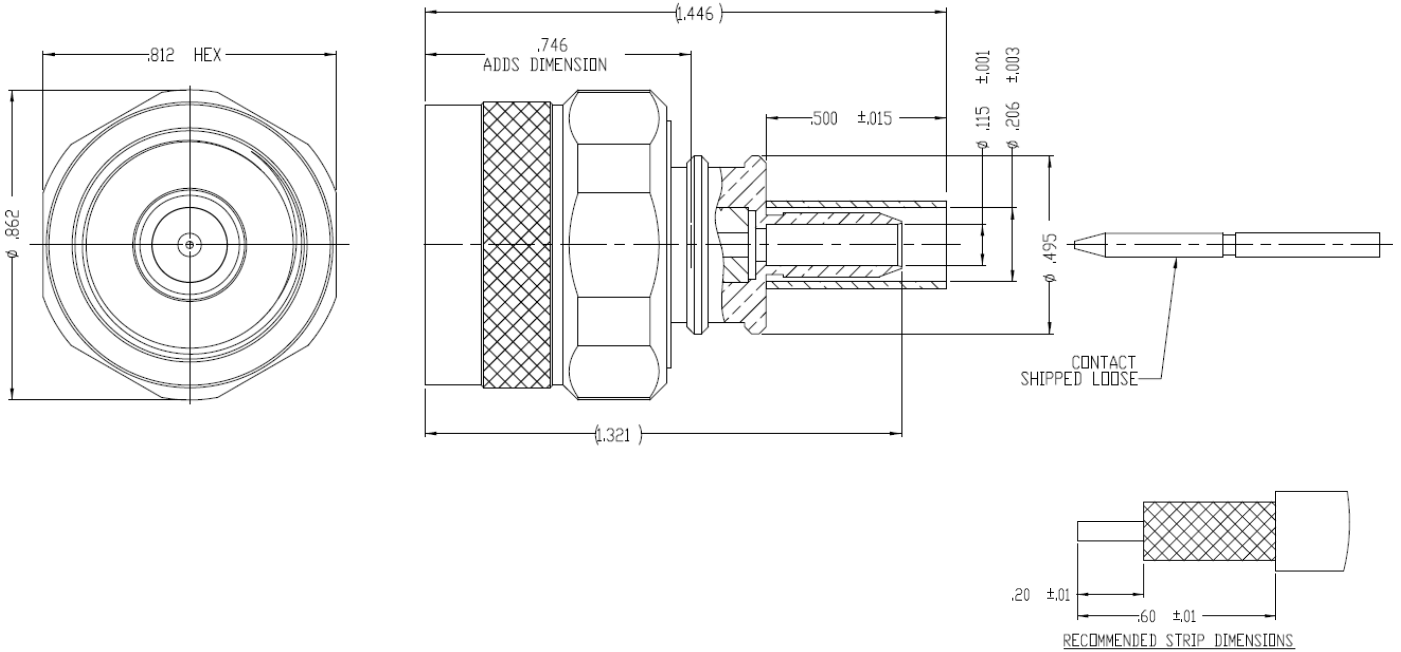

NOTES:

- ASSEMBLED CONNECTOR INTERFACE IS DESIGNED IN ACCORDANCE WITH MIL-STD-348.
- MATERIAL:**
 BODY, CONTACT - BRASS PER ASTM B16, C36000 ALLOY, TEMPER H02
 INSULATOR - TEFLON PER ASTM D1710, TYPE 1, GRADE 1, CLASS A
 SHRINK SLEEVE - HEAT SHRINKABLE ATUM PER MIL-I-23053/4 (NOT SHOWN)
 CRIMP SLEEVE - D.H.P. COPPER CDA, ALLOY #122, TEMPER HARD
 GASKET - SILICONE RUBBER PER A-A-59588, 50-75 DUROMETER
 LOCKING RING - PHOSPHOR BRONZE PER ASTM B139, C54400 ALLOY, TEMPER HD
- FINISH:**
 CONTACT - GOLD PLATE PER ASTM B488
 CRIMP SLEEVE - SILVER PLATE PER ASTM B700
 ALL OTHER METAL PARTS - ALBALOY PLATE

MATERIAL:	UNLESS OTHERWISE SPECIFIED ALL DIMENSIONS ARE IN INCHES MACHINED SURFACES FINISH 63 RMS MAX. REMOVE ALL BURRS .004 MAX. BREAK MACHINE CORNERS .005 MAX. FILLET R. TOLERANCES ON DECIMALS .XX $\pm .01$.XXX $\pm .005$ ANGLES $\pm 1^\circ$ FRACTIONS $\pm 1/64$	DFTM. N. N. N	TIMES MICROWAVE SYSTEMS	
		DATE 1/15/14		
USED ON: -		CHKD. J. D. B.	TC-195-NMH-X CONNECTOR ASSEMBLY N Male for LMR-195	
		DATE 1/15/14		
SCALE: NONE	DWG. SIZE A	APPD. J. D. B.	SHEET 1 of 1 SD3190-2880 REV A	
		DATE 1/15/14		
DO NOT SCALE DRAWING	CODE IDENT 68999			



Flexible RG303 Coax Cable Single Shielded with Tan FEP Jacket

TECHNICAL DATA SHEET

RG303/U

Flexible RG303 Coax Cable Single Shielded with Tan FEP Jacket

Configuration

Inner Conductor Material and Plating	Copper Clad Steel, Silver
Dielectric Type	PTFE
Shield Materials	Silver Plated Copper Braid
Jacket Material and Color	FEP, Tan

Electrical Specifications

Impedance, Ohms	50
Maximum Operating Frequency, GHz	3
Capacitance, pF/ft [pF/m]	32 [104.99]
Dielectric Withstanding Voltage, Vrms	5,000

Electrical Specifications by Frequency

Frequency 1

Frequency, MHz	400
Attenuation, dB/100ft [dB/100m]	8.6 [28.22]

Mechanical Specifications

Inner Conductor

Number of Strands	1
Material	Copper Clad Steel
Plating	Silver
Diameter, in [mm]	0.037 [0.94]

Dielectric:

Type	PTFE
Diameter, in [mm]	0.116 [2.95]

Shield:

Number of	1
Material 1	Silver Plated Copper Braid
Diameter, in [mm]	0.146 [3.71]

Jacket:

Material	FEP
Diameter, in [mm]	0.17 [4.32]
Color	Tan
Weight, lbs/ft [Kg/m]	0.039 [0.06]

Click the following link (or enter part number in "SEARCH" on website) to obtain additional part information including price, inventory and certifications: [Flexible RG303 Coax Cable Single Shielded with Tan FEP Jacket RG303/U](#)

The information contained in this document is accurate to the best of our knowledge and representative of the part described herein. It may be necessary to make modifications to the part and/or the documentation of the part, in order to implement improvements. Pasternack reserves the right to make such changes as required. Unless otherwise stated, all specifications are nominal.



Flexible RG303 Coax Cable Single Shielded with Tan FEP Jacket

TECHNICAL DATA SHEET

RG303/U

Compliance Certifications (visit www.Pasternack.com for current document)

RoHS Compliant

Yes

Plotted and Other Data

Notes:

Values at 25 °C, sea level

Flexible RG303 Coax Cable Single Shielded with Tan FEP Jacket from Pasternack Enterprises has same day shipment for domestic and International orders. Our RF, microwave and fiber optic products maintain a 99% availability and are part of the broadest selection in the industry.

Click the following link (or enter part number in "SEARCH" on website) to obtain additional part information including price, inventory and certifications: [Flexible RG303 Coax Cable Single Shielded with Tan FEP Jacket RG303/U](#)

URL: <http://www.pasternack.com/flexible-0.170-rg303-50-ohm-coax-cable-fep-jacket-rg303-u-p.aspx>

The information contained in this document is accurate to the best of our knowledge and representative of the part described herein. It may be necessary to make modifications to the part and/or the documentation of the part, in order to implement improvements. Pasternack reserves the right to make such changes as required. Unless otherwise stated, all specifications are nominal.

RG303/U CAD Drawing

Flexible RG303 Coax Cable Single Shielded with Tan FEP Jacket

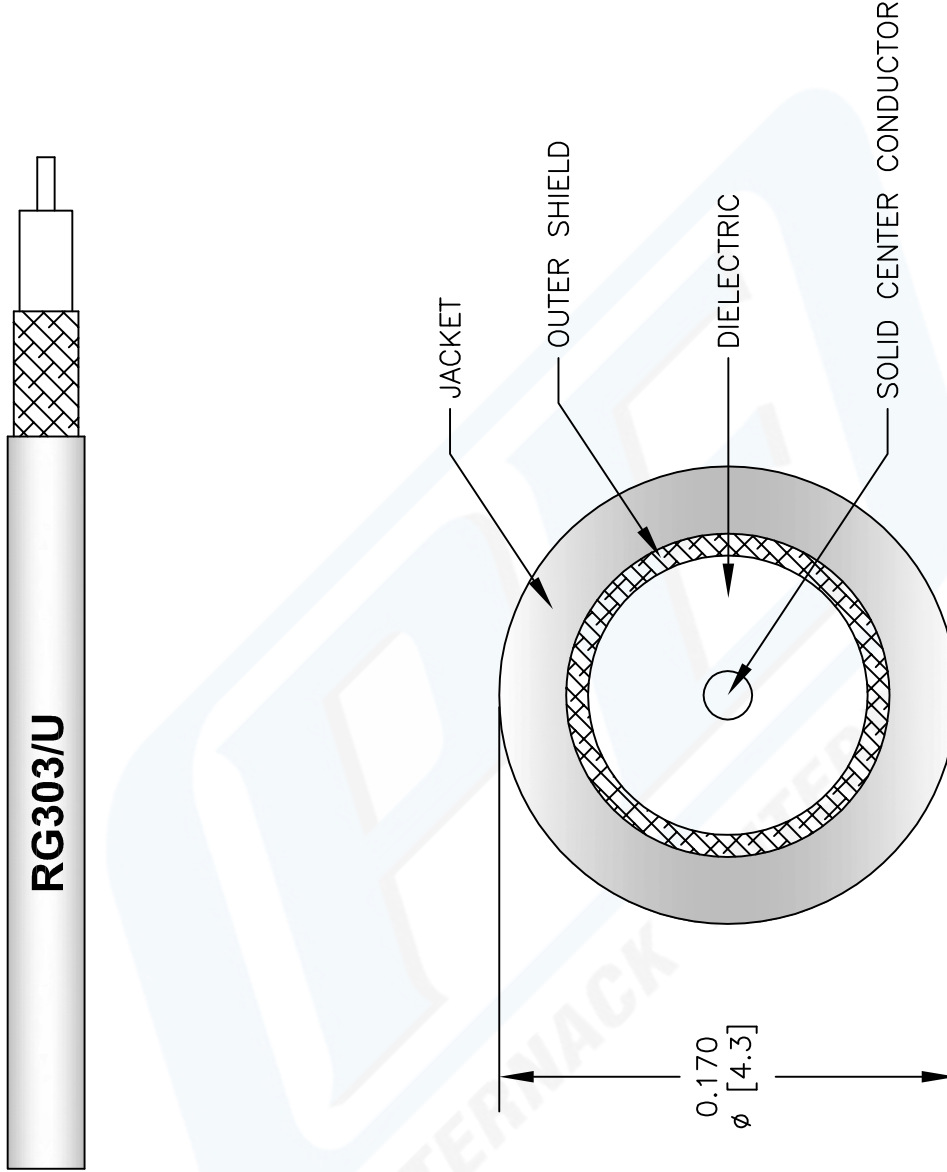

NOTES:
 1. UNLESS OTHERWISE SPECIFIED ALL DIMENSIONS ARE NOMINAL.
 2. ALL SPECIFICATIONS ARE SUBJECT TO CHANGE WITHOUT NOTICE AT ANY TIME.
 3. DIMENSIONS ARE IN INCHES (mm).

DWG TITLE
RG303/U

CAD FILE	022908-A	SCALE	N/A	SIZE	A
					147

REV. A	FSCM NO. 53919
--------	----------------

PE PASTERNAK®
 Pasternack Enterprises, Inc.
 P.O. Box 16759 | Irvine | CA | 92623
Phone: (949) 261-1920 | **Fax:** (949) 261-7451
Website: www.pasternack.com | **E-Mail:** sales@pasternack.com