



## N Male Connector Crimp/Solder Attachment for RG214, RG9, RG225, RG393

### RF Connectors Technical Data Sheet

**PE4048**

#### Configuration

- N Male Connector
- MIL-STD-348A
- 50 Ohms
- Straight Body Geometry
- Connector Interface Types: RG214, RG9, RG225, RG393

#### Features

- Max. Operating Frequency 11 GHz
- Good VSWR of 1.5:1
- Gold Plated Brass Contact
- 30 µin minimum contact plating

#### Applications

- General Purpose Test
- Custom Cable Assemblies

#### Description

Pasternack's PE4048 type N male connector with crimp/solder attachment for RG214, RG9, RG225 and RG393 is part of our full line of RF components available for same-day shipping. Our type N male connector operates up to a maximum frequency of 11 GHz and offers good VSWR of 1.5:1.

Our type N male connector PE4048 datasheet specifications and drawing with dimensions are shown below in this PDF. Pasternack's broad catalog of RF, microwave and millimeter wave connectors allows designers to configure and customize their signal connections however they like. Whether the need is to provide an I/O for a board design, or simply create a custom cable assembly configuration, Pasternack has the right connector for the job. Pasternack can also expertly build your custom cable assemblies for you and ship same-day.

#### Electrical Specifications

Description	Minimum	Typical	Maximum	Units
Frequency Range	DC		11	GHz
VSWR			1.5:1	
Operating Voltage (AC)			1,000	Vrms

#### Mechanical Specifications

##### Size

Length	1.583 in [40.21 mm]
Width/Dia.	0.79 in [20.07 mm]
Weight	0.072 lbs [32.66 g]

Click the following link (or enter part number in "SEARCH" on website) to obtain additional part information including price, inventory and certifications: [N Male Connector Crimp/Solder Attachment for RG214, RG9, RG225, RG393 PE4048](#)



N Male Connector Crimp/Solder Attachment  
for RG214, RG9, RG225, RG393

**RF Connectors**  
**Technical Data Sheet**

**PE4048**

**Material Specifications**

Description	Material	Plating
Contact	Brass	Gold 30 µin minimum
Insulation	PTFE	
Body	Brass	Nickel 100 µin minimum
Coupling Nut	Brass	Nickel 100 µin minimum
Crimp Sleeve	Brass	Nickel

**Environmental Specifications**

**Temperature**

Operating Range -65 to +165 deg C

**Compliance Certifications** (see [product page](#) for current document)

**Plotted and Other Data**

Notes:

N Male Connector Crimp/Solder Attachment for RG214, RG9, RG225, RG393 from Pasternack Enterprises has same day shipment for domestic and International orders. Our RF, microwave and millimeter wave products maintain a 99.4% availability and are part of the broadest selection in the industry.

Click the following link (or enter part number in "SEARCH" on website) to obtain additional part information including price, inventory and certifications: [N Male Connector Crimp/Solder Attachment for RG214, RG9, RG225, RG393 PE4048](#)

URL: <https://www.pasternack.com/n-male-standard-rg214-rg9-rg225-rg393-connector-pe4048-p.aspx>

The information contained in this document is accurate to the best of our knowledge and representative of the part described herein. It may be necessary to make modifications to the part and/or the documentation of the part, in order to implement improvements. Pasternack reserves the right to make such changes as required. Unless otherwise stated, all specifications are nominal. Pasternack does not make any representation or warranty regarding the suitability of the part described herein for any particular purpose, and Pasternack does not assume any liability arising out of the use of any part or documentation.

# PE4048 CAD Drawing

N Male Connector Crimp/Solder Attachment for RG214, RG9, RG225, RG393

REVISIONS			
REV.	DESCRIPTION	DATE	APPROVED
B	PCR PE4048 20220622	6/27/2022	RDELEON

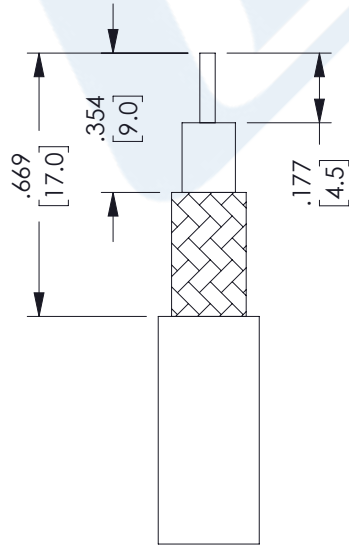
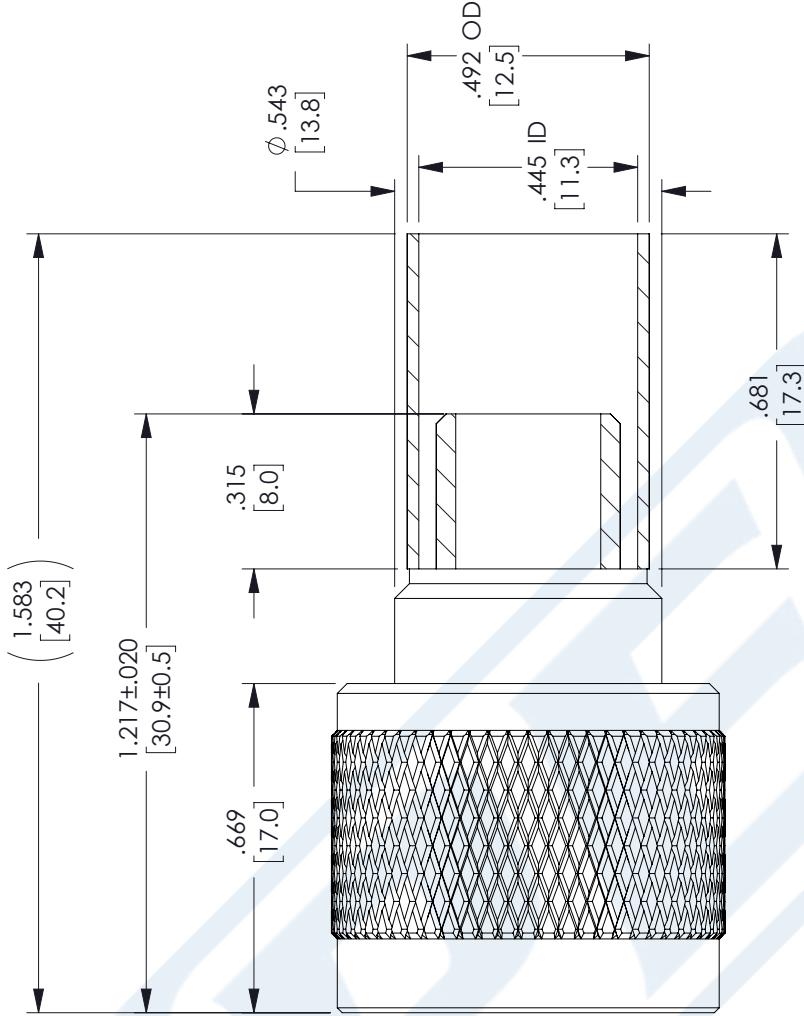

## STRIPPING DIMENSIONS

## CRIMP SIZES REQUIRED

CONTACT: .100" HEX CRIMP TOOL  
 FERRULE: .429" HEX CRIMP TOOL

UNLESS OTHERWISE SPECIFIED  
 LEADING DIMENSIONS ARE INCHES  
 DIMENSIONS IN [ ] ARE MILLIMETERS

TOLERANCES:

.X = ± .2	[5.08]	FRACTIONS
.XX = ± .02	[.51]	± 1/32
.XXX = ± .005	[.13]	ANGLES ± 1°

CABLE LENGTH (L) TOLERANCES:

L ≤ 12	[305]	= +1 [25] / -0
12 [305] < L ≤ 60	[1524]	= +2 [51] / -0
60 [1524] < L ≤ 120	[3048]	= +4 [102] / -0
120 [3048] < L ≤ 300	[7620]	= +6 [152] / -0
300 [7620] < L		= +5%L / -0

ALL DIMENSIONS SHOWN  
 ARE FOR REFERENCE ONLY.

**PE PASTERNAK**  
 an INFINIT® brand

Pasternack Enterprises, Inc.  
 P.O. Box 16759, Irvine, CA 92623.  
 Phone: 1.949.261.1920 | 1.866.727.8376  
 Fax: 1.949.261.7451  
 Website: www.pasternack.com  
 E-mail: sales@pasternack.com

ITEM NO. PE4048

SIZE A CAGE CODE 53919 DRAWN BY DMAY

THIRD-ANGLE PROJECTION

THE INFORMATION AND  
 DESIGN IN THIS DOCUMENT  
 IS THE PROPERTY OF  
 PASTERNAK CORPORATION  
 ALL RIGHTS RESERVED.

SHEET 1 OF 1

SCALE N/A

REV B



N Female Bulkhead Connector Clamp/Solder Attachment For RG213, RG214, RG8, RG9, RG11, RG225, RG393, .640 inch DD Hole

## RF Connectors Technical Data Sheet

**PE4223**

### Configuration

- N Female Connector
- MIL-STD-348A
- 50 Ohms
- Straight Body Geometry
- Connector Interface Types: RG214, RG213, RG393, RG8, RG225, RG11, RG216, RG144, RG215, RG9
- Bulkhead

### Features

- Max. Operating Frequency 11 GHz
- Good VSWR of 1.35:1
- Gold Plated Brass Contact
- 30 µin minimum contact plating

### Applications

- General Purpose Test
- Rack and Panel Mount Applications
- Custom Cable Assemblies

### Description

Pasternack's PE4223 type N female bulkhead connector with clamp/solder attachment for RG214, RG213, RG393, RG8, RG225, RG11, RG216, RG144, RG215 and RG9 (.640 inch DD hole) is part of our full line of RF components available for same-day shipping. Our type N female connector operates up to a maximum frequency of 11 GHz and offers good VSWR of 1.35:1. This type N bulkhead connector allows designers to create external connections on their product enclosures, and can be used in a variety of other rack mount and panel mount applications.

Our type N female bulkhead connector PE4223 datasheet specifications and drawing with dimensions are shown below in this PDF. Pasternack's broad catalog of RF, microwave and millimeter wave connectors allows designers to configure and customize their signal connections however they like. Whether the need is to provide an I/O for a board design, or simply create a custom cable assembly configuration, Pasternack has the right connector for the job. Pasternack can also expertly build your custom cable assemblies for you and ship same-day.

### Electrical Specifications

Description	Minimum	Typical	Maximum	Units
Frequency Range	DC		11	GHz
VSWR			1.35:1	
Operating Voltage (AC)			1,000	Vrms

### Mechanical Specifications

<b>Size</b>	
Length	1.583 in [40.21 mm]
Width/Dia.	0.825 in [20.96 mm]
Weight	0.131 lbs [59.42 g]

Click the following link (or enter part number in "SEARCH" on website) to obtain additional part information including price, inventory and certifications: [N Female Bulkhead Connector Clamp/Solder Attachment For RG213, RG214, RG8, RG9, RG11, RG225, RG393, .640 inch DD Hole PE4223](#)



N Female Bulkhead Connector Clamp/Solder Attachment For RG213, RG214, RG8, RG9, RG11, RG225, RG393, .640 inch DD Hole

**RF Connectors**  
**Technical Data Sheet**

**PE4223**

**Material Specifications**

Description	Material	Plating
Contact	Brass	Gold 30 µin minimum
Insulation	PTFE	
Body	Brass	Nickel

**Mechanical Specification Notes:**

When attaching the connector to the cable use a clamp torque value of 60 to 65 in-lbs [6.78 to 7.34 Nm]

**Environmental Specifications**

**Temperature**

Operating Range -65 to +165 deg C

**Compliance Certifications** (see [product page](#) for current document)

**Plotted and Other Data**

Notes:

Click the following link (or enter part number in "SEARCH" on website) to obtain additional part information including price, inventory and certifications: [N Female Bulkhead Connector Clamp/Solder Attachment For RG213, RG214, RG8, RG9, RG11, RG225, RG393, .640 inch DD Hole PE4223](#)



N Female Bulkhead Connector Clamp/Solder Attachment For RG213, RG214, RG8, RG9, RG11, RG225, RG393, .640 inch DD Hole

**RF Connectors**  
**Technical Data Sheet**

**PE4223**

**Assembly Instruction**

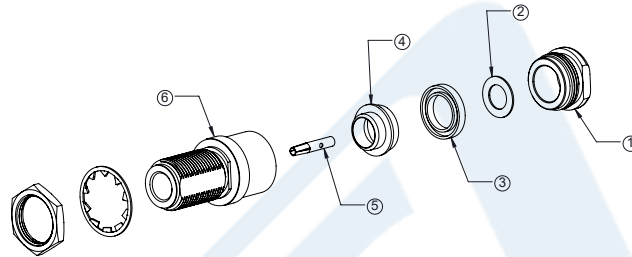

1. SLIDE CLAMP NUT (1), WASHER (2) AND GASKET (3) OVER CABLE. STRIP CABLE AS SHOWN. DO NOT NICK BRAID WHILE CUTTING JACKET. TAPER END OF BRAID TO PERMIT ASSEMBLY OF CLAMP.

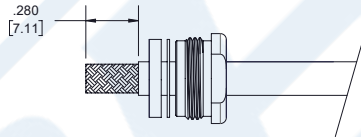

2. SLIDE BRAID CLAMP (4) OVER BRAID & SEAT AGAINST CABLE. FORM BRAID OVER BRAID CLAMP (4). TRIM BRAID BACK TO SHOULDER. CUT DIELECTRIC & CENTER CONDUCTOR TO DIMENSIONS SHOWN. DO NOT NICK CENTER CONDUCTOR.

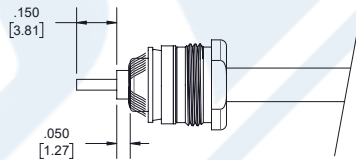

3. SLIDE CONTACT (5) OVER THE CENTER CONDUCTOR. SOLDER & REMOVE EXCESS SOLDER. DO NOT OVER HEAT DIELECTRIC. INSERT CABLE ASSEMBLY INTO BODY (6) & TIGHTEN.

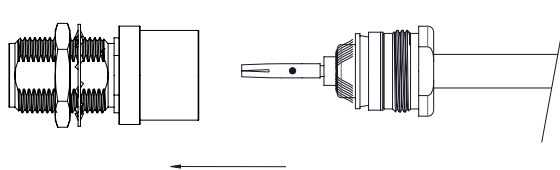
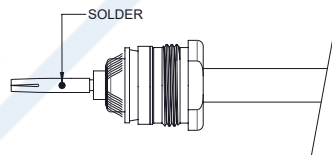

Click the following link (or enter part number in "SEARCH" on website) to obtain additional part information including price, inventory and certifications: [N Female Bulkhead Connector Clamp/Solder Attachment For RG213, RG214, RG8, RG9, RG11, RG225, RG393, .640 inch DD Hole PE4223](#)



N Female Bulkhead Connector Clamp/Solder Attachment For RG213, RG214, RG8, RG9, RG11, RG225, RG393, .640 inch DD Hole

## RF Connectors Technical Data Sheet

**PE4223**

N Female Bulkhead Connector Clamp/Solder Attachment For RG213, RG214, RG8, RG9, RG11, RG225, RG393, .640 inch DD Hole from Pasternack Enterprises has same day shipment for domestic and International orders. Our RF, microwave and millimeter wave products maintain a 99.4% availability and are part of the broadest selection in the industry.

Click the following link (or enter part number in "SEARCH" on website) to obtain additional part information including price, inventory and certifications: [N Female Bulkhead Connector Clamp/Solder Attachment For RG213, RG214, RG8, RG9, RG11, RG225, RG393, .640 inch DD Hole PE4223](https://www.pasternack.com/n-female-standard-rg213-rg214-rg8-rg9-rg11-rg225-rg393-connector-pe4223-p.aspx)

URL: <https://www.pasternack.com/n-female-standard-rg213-rg214-rg8-rg9-rg11-rg225-rg393-connector-pe4223-p.aspx>

The information contained in this document is accurate to the best of our knowledge and representative of the part described herein. It may be necessary to make modifications to the part and/or the documentation of the part, in order to implement improvements. Pasternack reserves the right to make such changes as required. Unless otherwise stated, all specifications are nominal. Pasternack does not make any representation or warranty regarding the suitability of the part described herein for any particular purpose, and Pasternack does not assume any liability arising out of the use of any part or documentation.

# PE4223 CAD Drawing

N Female Bulkhead Connector Clamp/Solder Attachment For RG213, RG214, RG8, RG9, RG11, RG225, RG393, .640 inch DD Hole

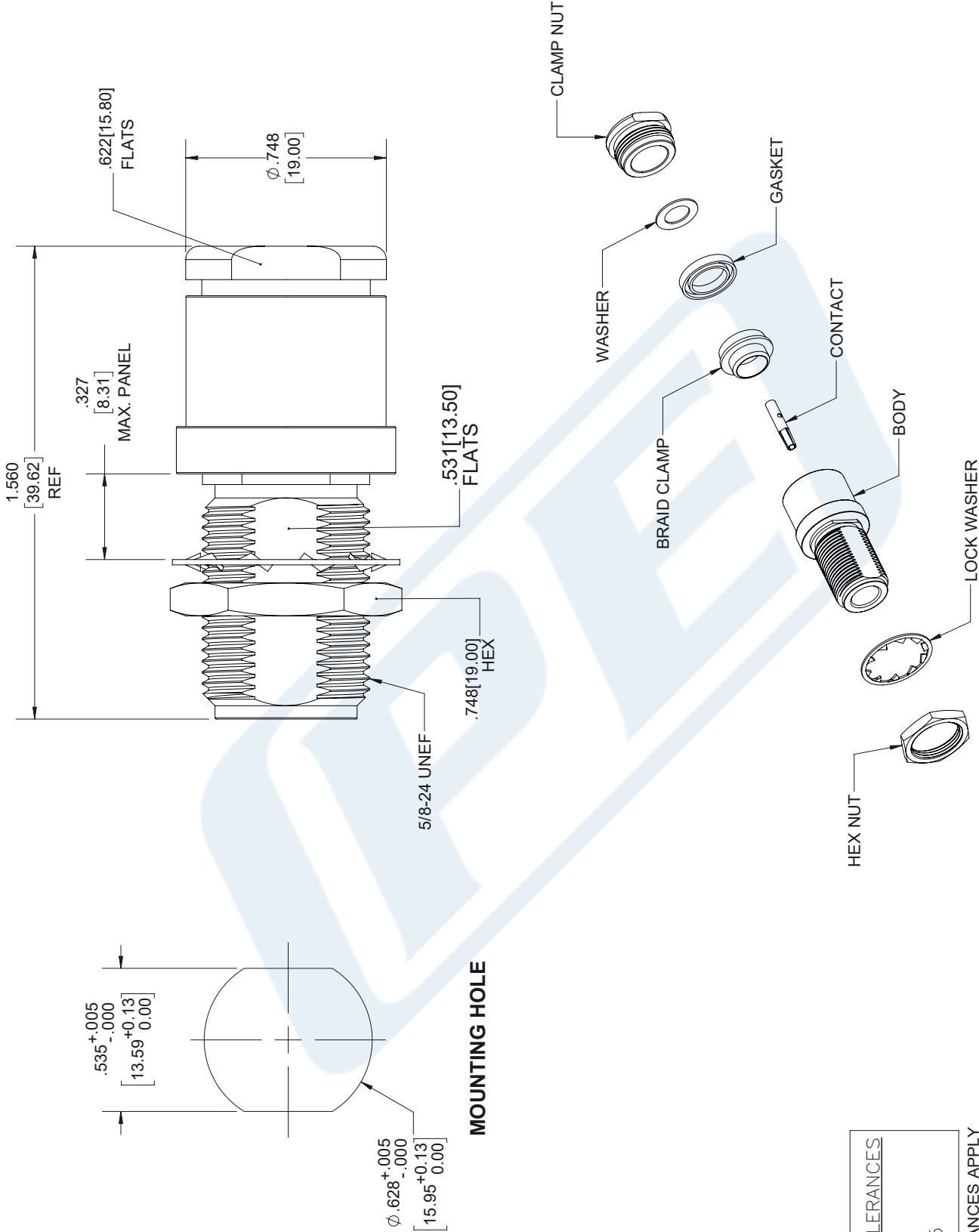

STANDARD TOLERANCES	
.X	±0.2
.XX	±0.01
.XXX	±0.005

\*STANDARD TOLERANCES APPLY ONLY TO DIMENSIONS IN INCHES

<p><b>PE PASTERNAK</b> THE ENGINEER'S RF SOURCE Pasternack Enterprises, Inc. P.O. Box 16759   Irvine   CA   92623 Phone: (949) 261-1920   Fax: (949) 261-7451 Website: www.pasternack.com   E-Mail: sales@pasternack.com</p>	<p>DWG TITLE <b>PE4223</b></p>	<p>NOTES: 1. UNLESS OTHERWISE SPECIFIED ALL DIMENSIONS ARE NOMINAL. 2. ALL SPECIFICATIONS ARE SUBJECT TO CHANGE WITHOUT NOTICE AT ANY TIME. 3. DIMENSIONS ARE IN INCHES [mm].</p>
	<p>CAGE CODE <b>53919</b></p>	<p>CAD FILE 05/17/18</p>
<p>© 2020 Pasternack Enterprises All Rights Reserved</p>		<p>SIZE A</p>
<p>PE4223 REV 1.4</p>		<p>7361</p>



## Flexible RG393 Coax Cable Double Shielded with Tan FEP Jacket

### RF Cables Technical Data Sheet

RG393/U

#### Configuration

- Flexible Cable
- 2 Shield(s)

#### Features

- 50 Ohm Impedance
- Stranded Silver Plated Copper center conductor
- PTFE dielectric
- Double Silver Plated Copper Braid
- FEP Jacket Material 0.390 in diameter

#### Electrical Specifications

Description	Minimum	Typical	Maximum	Units
Frequency Range	DC		10	GHz
Impedance		50		Ohms
Velocity of Propagation		69.5		%
Nominal Capacitance		29.4 [96.46]		pF/ft [pF/m]

#### Performance by Frequency Band

Description	F1	F2	F3	F4	F5	Units
Frequency	0.01	0.1	1	5	10	GHz
Attenuation, Typ	0.6	2.1	7.5	21	35	dB/100ft
	1.97	6.89	24.61	68.9	114.83	dB/100m
Input Power (CW), Max	25,000	6,300	1,700	620	350	Watts

#### Mechanical Specifications

Diameter	0.39 in [9.91 mm]
Weight	0.157 lbs/ft [0.23 Kg/m]
Min. Bend Radius (Repeated)	3.9 in [99.06 mm]

#### Construction Specifications

Description	Material and Plating	Diameter
Inner Conductor	Copper, Silver7	0.094 in 2.39 mm
Conductor Type	Stranded	

Click the following link (or enter part number in "SEARCH" on website) to obtain additional part information including price, inventory and certifications: [Flexible RG393 Coax Cable Double Shielded with Tan FEP Jacket RG393/U](#)



## Flexible RG393 Coax Cable Double Shielded with Tan FEP Jacket

### RF Cables Technical Data Sheet

RG393/U

Dielectric	PTFE	0.285 in 7.24 mm
First Shield	Silver Plated Copper Braid 90% coverage	0.313 in 7.95 mm
Second Shield	Silver Plated Copper Braid 90% coverage	0.341 in 8.66 mm
Jacket	FEP, Tan	0.39 in [9.91 mm]

#### Environmental Specifications

##### Temperature

Operating Range

-55 to +200 deg C

**Compliance Certifications** (see [product page](#) for current document)

#### Plotted and Other Data

Notes:

Flexible RG393 Coax Cable Double Shielded with Tan FEP Jacket from Pasternack Enterprises has same day shipment for domestic and International orders. Our RF, microwave and millimeter wave products maintain a 99.4% availability and are part of the broadest selection in the industry.

Click the following link (or enter part number in "SEARCH" on website) to obtain additional part information including price, inventory and certifications: [Flexible RG393 Coax Cable Double Shielded with Tan FEP Jacket RG393/U](#)

URL: <https://www.pasternack.com/flexible-rg393u-fep-jacket-silver-plated-copper-braid-over-silver-plated-copper-braid-outer-conductor-double-shielded-rg393-u-p.aspx>

The information contained in this document is accurate to the best of our knowledge and representative of the part described herein. It may be necessary to make modifications to the part and/or the documentation of the part, in order to implement improvements. Pasternack reserves the right to make such changes as required. Unless otherwise stated, all specifications are nominal. Pasternack does not make any representation or warranty regarding the suitability of the part described herein for any particular purpose, and Pasternack does not assume any liability arising out of the use of any part or documentation.

# RG393/U CAD Drawing

Flexible RG393 Coax Cable Double Shielded with Tan FEP Jacket

REVISIONS			
REV.	DESCRIPTION	DATE	APPROVED
A	PCR RG393/U	1/8/2020	SELLIS

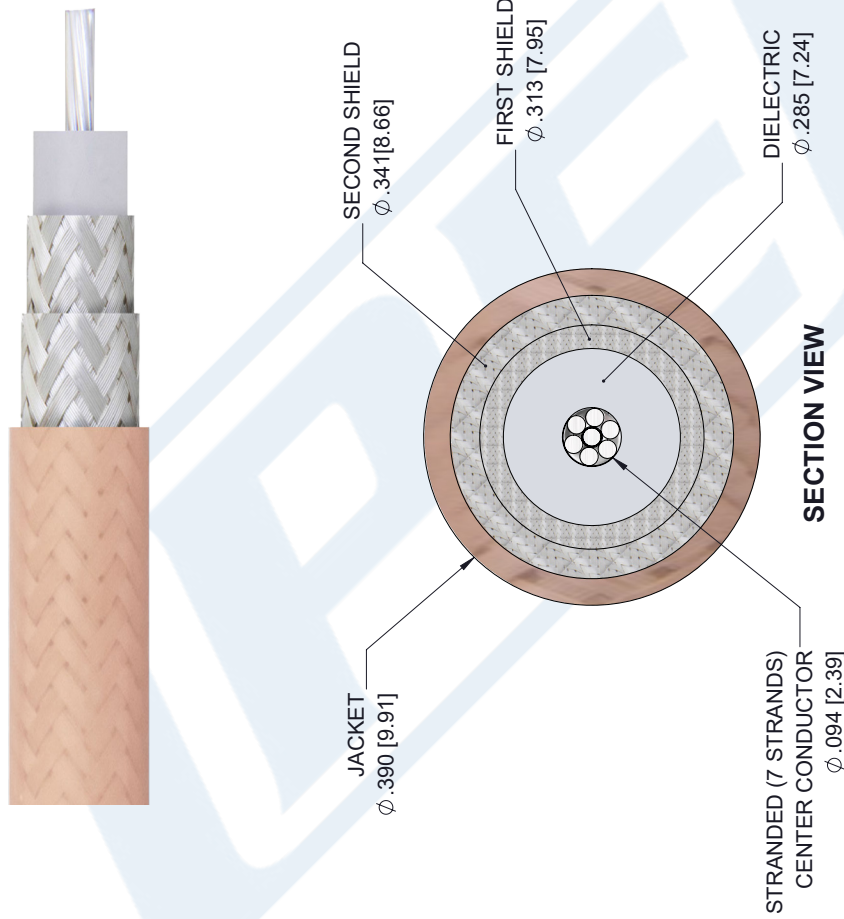

UNLESS OTHERWISE SPECIFIED  
LEADING DIMENSIONS ARE INCHES  
DIMENSIONS IN [ ] ARE MILLIMETERS

**TOLERANCES:**

.X = ±.2	[5.08]	FRACTIONS
.XX = ±.02	[.51]	± 1/32
.XXX = ±.005	[.13]	ANGLES ± 1°

**CABLE LENGTH (L) TOLERANCES:**

L ≤ 12	[305]	= +1 [25] / -0
12 [305] < L ≤ 60	[1524]	= +2 [51] / -0
60 [1524] < L ≤ 120	[3048]	= +4 [102] / -0
120 [3048] < L ≤ 300	[7620]	= +6 [152] / -0
300 [7620] < L		= +5%L / -0

ALL DIMENSIONS SHOWN  
ARE FOR REFERENCE ONLY.

**PE PASTERNAK**  
an INFINITI brand

Pasternack Enterprises, Inc.  
P.O. Box 16759, Irvine, CA 92623.  
Phone: 1.949.261.1920 | 1.866.727.8376  
Fax: 1.949.261.7451  
Website: www.pasternack.com  
E-mail: sales@pasternack.com

THIRD-ANGLE PROJECTION

THE INFORMATION AND DESIGN IN THIS DOCUMENT IS THE PROPERTY OF PASTERNAK CORPORATION. ALL RIGHTS RESERVED.

SHEET 1 OF 1  
SCALE N/A

SIZE [CAGE CODE] DRAWN BY [ITEM NO.]  
A 53919 K.DANG RG393/U  
REV A