



**BMA Jack MIL-STD-38999 (D38999) Connector**  
**Solder Attachment for RG405, PE-SR405AL,**  
**PE-SR405FL, PE-SR405FLJ**

RF Connectors Technical Data Sheet

PE45325

**Configuration**

- Snap-On BMA Jack Connector
- 50 Ohms
- Straight Body Geometry
- RG405, PE-SR405AL, PE-SR405FL, PE-SR405FLJ Interface Type
- Solder/Solder Attachment

**Features**

- Max. Operating Frequency 22 GHz
- Good VSWR of 1.27:1
- Gold Plated Beryllium Copper Contact
- 51.18µ in. minimum contact plating
- Blind Mate Connector
- IP54(Mated)
- Low-Engagement Force
- Radial and Axial Float Versions

**Applications**

- General Purpose Test
- Custom Cable Assemblies
- Blind Mating
- Rack and Panel
- Phased Array Systems
- Base Stations
- RF Backplanes
- Test I/O

**Description**

Pasternack's PE45325 BMA jack snap-on connector with solder/solder attachment for RG405, PE-SR405AL, PE-SR405FL and PE-SR405FLJ is part of our full line of RF components available for same-day shipping. Our BMA jack connector operates up to a maximum frequency of 22 GHz and offers good VSWR of 1.27:1. The Pasternack blind mate connector is ideal for applications where direct visual or tactile access to the connection point is not possible, for example, when two circuit boards need to be mated.

Our BMA jack connector PE45325 datasheet specifications and drawing with dimensions are shown below in this PDF. Pasternack's broad catalog of RF, microwave and millimeter wave connectors allows designers to configure and customize their signal connections however they like. Whether the need is to provide an I/O for a board design, or simply create a custom cable assembly configuration, Pasternack has the right connector for the job. Pasternack can also expertly build your custom cable assemblies for you and ship same-day.

**Electrical Specifications**

Description	Minimum	Typical	Maximum	Units
Frequency Range	DC		22	GHz
VSWR			1.27:1	
Insertion Loss			0.14	dB
Operating Voltage (AC)			500	Vrms
Dielectric Withstanding Voltage (AC)			1,000	Vrms
Insulation Resistance	5,000			MOhms

Click the following link (or enter part number in "SEARCH" on website) to obtain additional part information including price, inventory and certifications: [BMA Jack MIL-STD-38999 \(D38999\) Connector Solder Attachment for RG405, PE-SR405AL, PE-SR405FL, PE-SR405FLJ PE45325](#)



BMA Jack MIL-STD-38999 (D38999) Connector  
Solder Attachment for RG405, PE-SR405AL,  
PE-SR405FL, PE-SR405FLJ

## RF Connectors Technical Data Sheet

PE45325

### Mechanical Specifications

<b>Size</b>	
Length	0.84 in [21.34 mm]
Width/Dia.	0.315 in [8.00 mm]
Weight	0.007 lbs [3.18 g]
Mating Cycles	1,000 Cycles

### Material Specifications

Description	Material	Plating
Contact	Beryllium Copper	Gold 51.18μ in. minimum
Insulation	PTFE	
Outer Conductor	Beryllium Copper	Gold
Body	Stainless Steel	Gold 19.68μ in. minimum

Mechanical Specification Notes:

Recommended axial float mount for best electrical performance: 0.51 +/- 0.25 mm (.020" +/- .010)

### Environmental Specifications

<b>Temperature</b>	
Operating Range	-40 to +105 deg C
Ingress Protection (IP) Rating	IP54(Mated)

Click the following link (or enter part number in "SEARCH" on website) to obtain additional part information including price, inventory and certifications: [BMA Jack MIL-STD-38999 \(D38999\) Connector Solder Attachment for RG405, PE-SR405AL, PE-SR405FL, PE-SR405FLJ PE45325](#)



BMA Jack MIL-STD-38999 (D38999) Connector  
Solder Attachment for RG405, PE-SR405AL,  
PE-SR405FL, PE-SR405FLJ

## RF Connectors Technical Data Sheet

PE45325

**Compliance Certifications** (see [product page](#) for current document)

### Plotted and Other Data

Notes:

BMA Jack MIL-STD-38999 (D38999) Connector Solder Attachment for RG405, PE-SR405AL, PE-SR405FL, PE-SR405FLJ from Pasternack Enterprises has same day shipment for domestic and International orders. Our RF, microwave and millimeter wave products maintain a 99.4% availability and are part of the broadest selection in the industry.

Click the following link (or enter part number in "SEARCH" on website) to obtain additional part information including price, inventory and certifications: [BMA Jack MIL-STD-38999 \(D38999\) Connector Solder Attachment for RG405, PE-SR405AL, PE-SR405FL, PE-SR405FLJ PE45325](#)

URL: <https://www.pasternack.com/bma-jack-snap-on-rg405-pe-sr405al-pe-sr405fl-pe-sr405flj-connector-pe45325-p.aspx>

The information contained in this document is accurate to the best of our knowledge and representative of the part described herein. It may be necessary to make modifications to the part and/or the documentation of the part, in order to implement improvements. Pasternack reserves the right to make such changes as required. Unless otherwise stated, all specifications are nominal. Pasternack does not make any representation or warranty regarding the suitability of the part described herein for any particular purpose, and Pasternack does not assume any liability arising out of the use of any part or documentation.

# PE45325 CAD Drawing

BMA Jack MIL-STD-38999 (D38999) Connector Solder Attachment  
for RG405, PE-SR405AL, PE-SR405FL, PE-SR405FLJ

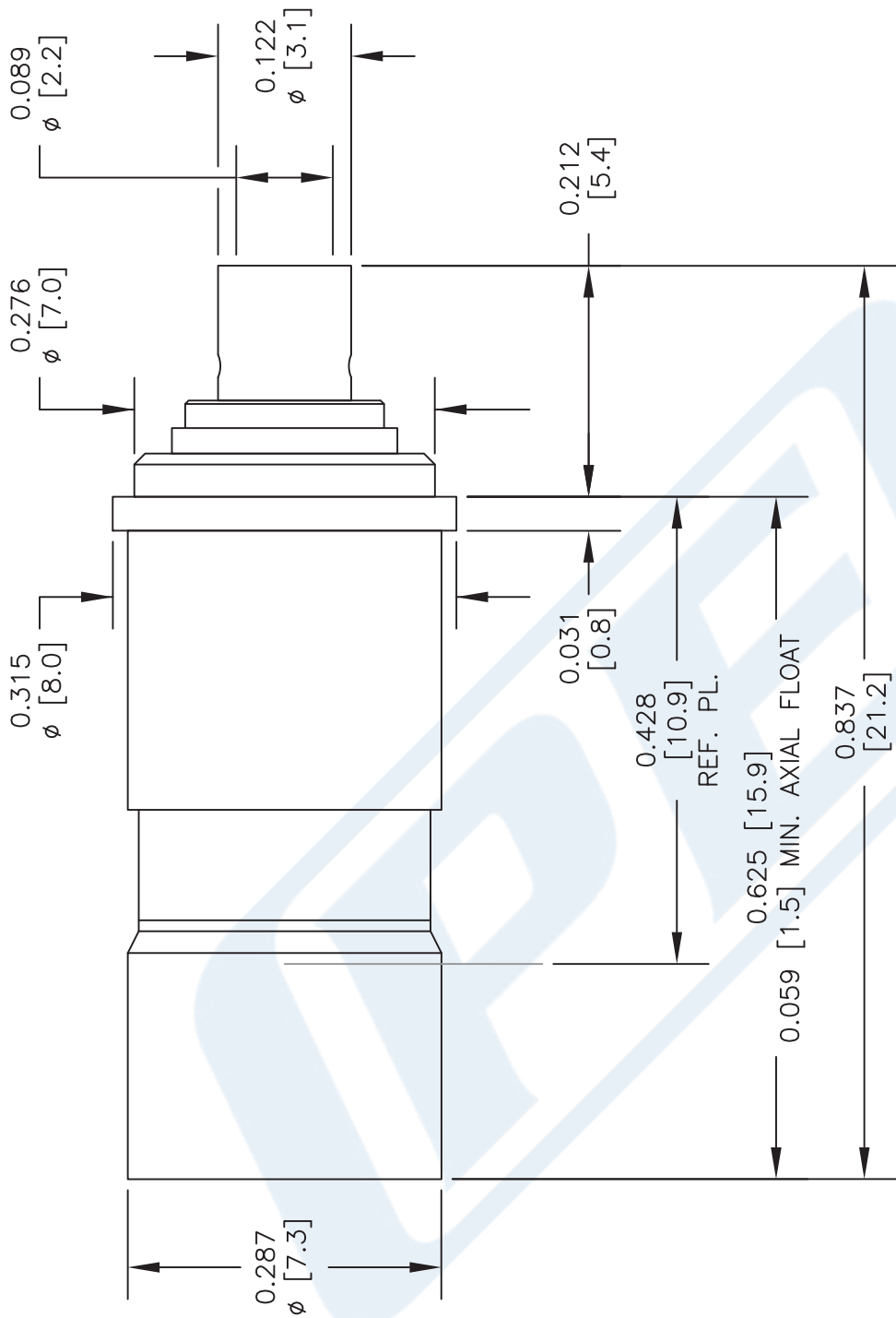

STANDARD TOLERANCES	
.X	±0.2
.XX	±0.1
.XXX	±0.05

\*STANDARD TOLERANCES APPLY ONLY TO DIMENSIONS IN INCHES

NOTES:  
1. UNLESS OTHERWISE SPECIFIED ALL DIMENSIONS ARE NOMINAL.  
2. ALL SPECIFICATIONS ARE SUBJECT TO CHANGE WITHOUT NOTICE AT ANY TIME.  
3. DIMENSIONS ARE IN INCHES [mm].

### ASSEMBLY PROCEDURES

1. STRIP CABLE AS SHOWN. DO NOT NICK CENTER CONDUCTOR.
2. SLIDE CABLE INTO CONNECTOR INSURING CENTER CONDUCTOR MATES WITH CENTER PIN.
3. OUTER CONDUCTOR BOTTOMS OUT WITH BODY SHOULDER. SOLDER OUTER CONDUCTOR TO BODY.

DWG TITLE	PE45325		
CAGE CODE	53919	CAD FILE	020817
SCALE	N/A	SIZE	A
			2233

**PE PASTERNAK**  
THE ENGINEER'S RF SOURCE  
Pasternack Enterprises, Inc.  
P.O. Box 16759 | Irvine | CA | 92623  
Phone: (949) 261-1920 | Fax: (949) 261-7451  
Website: www.pasternack.com | E-Mail: sales@pasternack.com



SMA Male Connector Solder Attachment for  
RG405, RG405 Tinned, PE-SR405AL, PE-  
SR405FL, PE-SR405FLJ, PE-SR405TN

RF Connectors  
Technical Data Sheet

PE45480

**Configuration**

- SMA Male Connector
- 50 Ohms
- Straight Body Geometry
- Connector Interface Types: RG405, RG405 Tinned, PE-SR405AL, PE-SR405FL, PE-SR405FLJ, PE-SR405TN

**Features**

- Max. Operating Frequency 26.5 GHz
- Excellent VSWR of 1.14:1
- Gold Plated Beryllium Copper Contact
- Contact plating according to ASTM-B488

**Applications**

- General Purpose Test
- Custom Cable Assemblies

**Description**

Pasternack's PE45480 SMA male connector with solder attachment for RG405, RG405 Tinned, PE-SR405AL, PE-SR405FL, PE-SR405FLJ and PE-SR405TN is part of our full line of RF components available for same-day shipping. Our SMA male connector operates up to a maximum frequency of 26.5 GHz and offers excellent VSWR of 1.14:1.

Our SMA male connector PE45480 datasheet specifications and drawing with dimensions are shown below in this PDF. Pasternack's broad catalog of RF, microwave and millimeter wave connectors allows designers to configure and customize their signal connections however they like. Whether the need is to provide an I/O for a board design, or simply create a custom cable assembly configuration, Pasternack has the right connector for the job. Pasternack can also expertly build your custom cable assemblies for you and ship same-day.

**Electrical Specifications**

Description	Minimum	Typical	Maximum	Units
Frequency Range	DC		26.5	GHz
VSWR			1.14:1	
Dielectric Withstanding Voltage (AC)			1,000	Vrms
High Potential Voltage			670	Vrms
Corona Discharge			250	Vrms
Insulation Resistance	5,000			MOhms
RF Leakage	-90			dB

Click the following link (or enter part number in "SEARCH" on website) to obtain additional part information including price, inventory and certifications: [SMA Male Connector Solder Attachment for RG405, RG405 Tinned, PE-SR405AL, PE-SR-405FL, PE-SR405FLJ, PE-SR405TN PE45480](#)



SMA Male Connector Solder Attachment for  
RG405, RG405 Tinned, PE-SR405AL, PE-  
SR405FL, PE-SR405FLJ, PE-SR405TN

RF Connectors  
Technical Data Sheet

PE45480

**Performance by Frequency**

Description	F1	F2	F3	F4	F5	Units
Frequency Range	DC to 18	18 to 26.5				GHz
VSWR, Max	1.11:1	1.14:1				

Electrical Specification Notes:  
Insertion Loss = 0.04\*SQRT(Fghz) dB

**Mechanical Specifications**

Mating Cycles 500 Cycles  
Mating Torque 7 to 10 in-lbs [0.79 to 1.13 Nm]

**Material Specifications**

Description	Material	Plating
Contact	Beryllium Copper	Gold ASTM-B488
Insulation	PTFE	
Body	Beryllium Copper	Gold ASTM-B488
Coupling Nut	Steel	
Gasket	Silicone Rubber	

**Environmental Specifications**

**Temperature**  
Operating Range -65 to +165 deg C  
**Shock** MIL-STD-202, Method 213, Condition I  
**Vibration** MIL-STD-202, Method 204, Condition D  
**Thermal Shock** MIL-STD-202, Method 107, Condition B

**Compliance Certifications** (see [product page](#) for current document)

**Plotted and Other Data**

Notes:

Click the following link (or enter part number in "SEARCH" on website) to obtain additional part information including price, inventory and certifications: [SMA Male Connector Solder Attachment for RG405, RG405 Tinned, PE-SR405AL, PE-SR-405FL, PE-SR405FLJ, PE-SR405TN PE45480](#)



SMA Male Connector Solder Attachment for  
RG405, RG405 Tinned, PE-SR405AL, PE-  
SR405FL, PE-SR405FLJ, PE-SR405TN

RF Connectors  
Technical Data Sheet

PE45480

Assembly Instruction

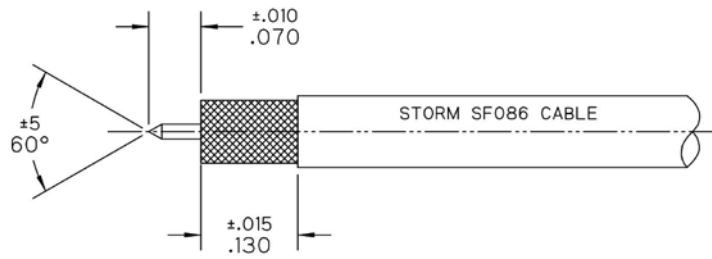

STEP 1:

- TRIM CABLE TO EXPOSE CENTER CONDUCTOR AND BRAID AS SHOWN.

STEP 2:

- INSERT CABLE INTO CONNECTOR UNTIL CENTER CONDUCTOR PLUGS IN AND CABLE FULLY SEATS IN CONNECTOR BORE.
- SOLDER BRAID TO BODY WHERE SHOWN APPLYING HEAT TO SHORT BODY TAIL SHOULDERS INSIDE COUPLING NUT.

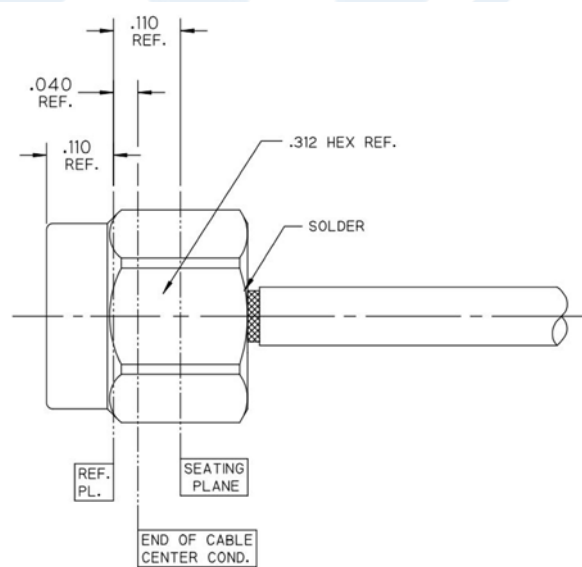

Click the following link (or enter part number in "SEARCH" on website) to obtain additional part information including price, inventory and certifications: [SMA Male Connector Solder Attachment for RG405, RG405 Tinned, PE-SR405AL, PE-SR-405FL, PE-SR405FLJ, PE-SR405TN PE45480](#)



SMA Male Connector Solder Attachment for  
RG405, RG405 Tinned, PE-SR405AL, PE-  
SR405FL, PE-SR405FLJ, PE-SR405TN

## RF Connectors Technical Data Sheet

PE45480

SMA Male Connector Solder Attachment for RG405, RG405 Tinned, PE-SR405AL, PE-SR405FL, PE-SR405FLJ, PE-SR405TN from Pasternack Enterprises has same day shipment for domestic and International orders. Our RF, microwave and millimeter wave products maintain a 99.4% availability and are part of the broadest selection in the industry.

Click the following link (or enter part number in "SEARCH" on website) to obtain additional part information including price, inventory and certifications: [SMA Male Connector Solder Attachment for RG405, RG405 Tinned, PE-SR405AL, PE-SR405FL, PE-SR405FLJ, PE-SR405TN PE45480](https://www.pasternack.com/sma-male-rg405-rg405-tinned-connector-pe45480-p.aspx)

URL: <https://www.pasternack.com/sma-male-rg405-rg405-tinned-connector-pe45480-p.aspx>

The information contained in this document is accurate to the best of our knowledge and representative of the part described herein. It may be necessary to make modifications to the part and/or the documentation of the part, in order to implement improvements. Pasternack reserves the right to make such changes as required. Unless otherwise stated, all specifications are nominal. Pasternack does not make any representation or warranty regarding the suitability of the part described herein for any particular purpose, and Pasternack does not assume any liability arising out of the use of any part or documentation.

# PE45480 CAD Drawing

SMA Male Connector Solder Attachment for RG405, RG405 Tinned, PE-SR405AL, PE-SR405FL, PE-SR405FLJ, PE-SR405TN

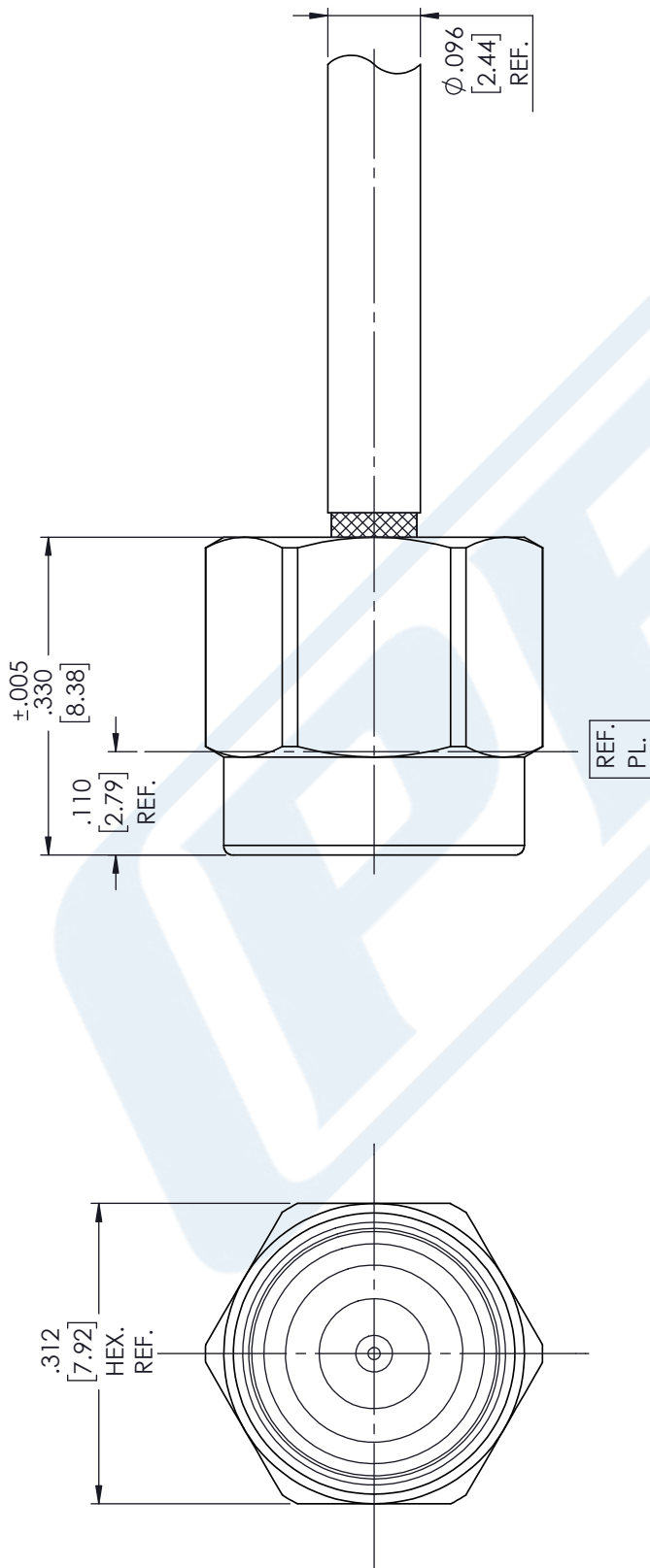

### STANDARD TOLERANCES

- .X ±0.2
- .XX ±0.01
- .XXX ±0.005

\*STANDARD TOLERANCES APPLY ONLY TO DIMENSIONS IN INCHES  
 NOTES: DISTANCE FROM END OF CABLE CENTER COND. TO REF. PL. IS .040



Pasternack Enterprises, Inc.  
 P.O. Box 16759 | Irvine | CA | 92623  
**Phone:** (949) 261-1920 | **Fax:** (949) 261-7451  
**Website:** www.pasternack.com | **E-Mail:** sales@pasternack.com

DWG TITLE

PE45480

**CAGE CODE 53919**

NOTES:  
 1. UNLESS OTHERWISE SPECIFIED ALL DIMENSIONS ARE NOMINAL.  
 2. ALL SPECIFICATIONS ARE SUBJECT TO CHANGE WITHOUT NOTICE AT ANY TIME.  
 3. DIMENSIONS ARE IN INCHES [mm].

CAD FILE 07/26/18

SCALE N/A

SIZE A

CN2379

## Formable 086 Semi-rigid Coax Cable with Tinned Copper Braid Outer Conductor

### RF Cables Technical Data Sheet

PE-SR405FL

#### Configuration

- Formable Cable
- 1 Shield(s)

#### Features

- Dimensionally the same as standard solid outer conductor semi-rigid coax
- Standard semi-rigid connectors can be used
- Cable is hand formable and does not require special tools to bend
- Connectors are easily soldered to Tin soaked outer conductor
- Cable can be formed more than once without damage to outer conductor
- High RF Shielding >100 dB

#### Description

Formable semi-rigid coax is a hand formable version of standard semi-rigid that does not require complicated and costly pre-formed cable assemblies. Because the dimensions and electrical characteristics are so closely matched to semi-rigid coax, standard semi-rigid connectors can be used. The tin soaked copper braid outer shield provides excellent RF shielding.

#### Electrical Specifications

Description	Minimum	Typical	Maximum	Units
Frequency Range	DC		20	GHz
Impedance		50		Ohms
Velocity of Propagation		69.5		%
Inner Conductor DC Resistance			65.7	Ohms/1000ft
Outer Conductor DC Resistance			10.2	Ohms/1000ft
Nominal Capacitance		29 [95.14]		pF/ft [pF/m]

#### Performance by Frequency Band

Description	F1	F2	F3	F4	F5	Units
Frequency	0.5	1	5	10	20	GHz
Attenuation, Typ	15	22.5	54.9	81.2	120	dB/100ft
	49.21	73.82	180.12	266.4	393.7	dB/100m

#### Mechanical Specifications

Min. Bend Radius (Repeated) 0.78 in [19.81 mm]

Click the following link (or enter part number in "SEARCH" on website) to obtain additional part information including price, inventory and certifications: [Formable 086 Semi-rigid Coax Cable with Tinned Copper Braid Outer Conductor PE-SR405FL](#)



# Formable 086 Semi-rigid Coax Cable with Tinned Copper Braid Outer Conductor

## RF Cables Technical Data Sheet

PE-SR405FL

### Construction Specifications

Description	Material and Plating	Diameter
Inner Conductor	Copper Clad Steel, Silver, 1 Strands	0.02 in [0.51 mm]
Conductor Type	Solid	
Dielectric	PTFE	0.062 in [1.57 mm]
Outer Conductor	Copper, Tin	0.085 in [2.16 mm]

### Environmental Specifications

**Compliance Certifications** (see [product page](#) for current document)

### Plotted and Other Data

Notes:

Formable 086 Semi-rigid Coax Cable with Tinned Copper Braid Outer Conductor from Pasternack Enterprises has same day shipment for domestic and International orders. Our RF, microwave and millimeter wave products maintain a 99.4% availability and are part of the broadest selection in the industry.

Click the following link (or enter part number in "SEARCH" on website) to obtain additional part information including price, inventory and certifications: [Formable 086 Semi-rigid Coax Cable with Tinned Copper Braid Outer Conductor PE-SR405FL](#)

URL: <https://www.pasternack.com/formable-0.085-semirigid-replacement-50-ohm-coax-cable-tinned-braid-pe-sr405fl-p.aspx>

The information contained in this document is accurate to the best of our knowledge and representative of the part described herein. It may be necessary to make modifications to the part and/or the documentation of the part, in order to implement improvements. Pasternack reserves the right to make such changes as required. Unless otherwise stated, all specifications are nominal. Pasternack does not make any representation or warranty regarding the suitability of the part described herein for any particular purpose, and Pasternack does not assume any liability arising out of the use of any part or documentation.



# PE-SR405FL CAD Drawing

Formable 086 Semi-rigid Coax Cable with Tinned Copper Braid Outer Conductor

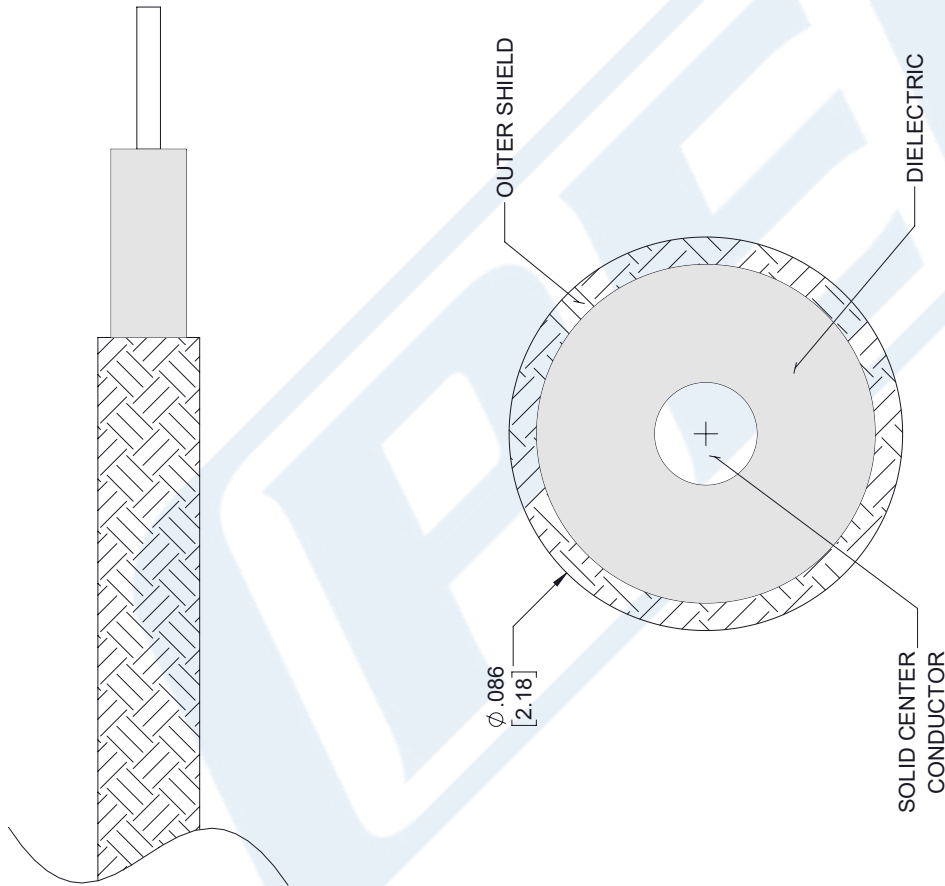

**STANDARD TOLERANCES**

.X ±0.2  
 .XX ±0.01  
 .XXX ±0.005

\*STANDARD TOLERANCES APPLY ONLY TO DIMENSIONS IN INCHES



Pasternack Enterprises, Inc.  
 P.O. Box 16759 | Irvine | CA | 92623  
**Phone:** (949) 261-1920 | **Fax:** (949) 261-7451  
**Website:** [www.pasternack.com](http://www.pasternack.com) | **E-Mail:** [sales@pasternack.com](mailto:sales@pasternack.com)

DWG TITLE

PE-SR405FL

NOTES:  
 1. UNLESS OTHERWISE SPECIFIED ALL DIMENSIONS ARE NOMINAL.  
 2. ALL SPECIFICATIONS ARE SUBJECT TO CHANGE WITHOUT NOTICE AT ANY TIME  
 3. DIMENSIONS ARE IN INCHES [mm].

CAGE CODE 53919

CAD FILE 112117

SCALE N/A

SIZE A

7361