



## 4.3-10 Male Connector Crimp/Solder Attachment for LMR-600

### RF Connectors Technical Data Sheet



TC-600-4310M-X

### Times Microwave Systems Connector Specification

#### Configuration

- 4.3-10 Male Connector
- 50 Ohms
- Straight Body Geometry
- LMR-600 Interface Type
- Crimp/Solder Attachment

#### Features

- Max. Operating Frequency 6 GHz
- Excellent VSWR of 1.25:1
- Silver Plated Brass Contact

#### Applications

- General Purpose Test
- Custom Cable Assemblies
- Mobile Communications Systems
- Base Stations
- Distributed Antenna Systems (DAS)
- Small Cells
- Feeder Cables

#### Description

The Times Microwave TC-600-4310M-X 4.3-10 male connector with crimp/solder attachment for LMR-600 is part of our full line of RF components available for same-day shipping. This 4.3-10 male connector operates up to a maximum frequency of 6 GHz and offers good VSWR of 1.25:1.

Our datasheet specifications and drawing with dimensions for Times Microwave's 4.3-10 male connector TC-600-4310M-X are shown below in this PDF. Pasternack's broad catalog of RF, microwave and millimeter wave connectors allows designers to configure and customize their signal connections however they like. Whether the need is to provide an I/O for a board design, or simply create a custom cable assembly configuration, Pasternack has the right connector for the job. Pasternack can also expertly build your custom cable assemblies for you and ship same-day.

#### Electrical Specifications

Description	Minimum	Typical	Maximum	Units
Frequency Range	DC		6	GHz
VSWR			1.25:1	
Insulation Resistance	10,000			MOhms

Electrical Specification Notes:  
 Insertion Loss = 0.1 x SQRT(FGHz)

#### Mechanical Specifications

Mating Cycles 500 Cycles

Click the following link (or enter part number in "SEARCH" on website) to obtain additional part information including price, inventory and certifications: [4.3-10 Male Connector Crimp/Solder Attachment for LMR-600 TC-600-4310M-X](#)



## 4.3-10 Male Connector Crimp/Solder Attachment for LMR-600

### RF Connectors Technical Data Sheet



TC-600-4310M-X

#### Material Specifications

Description	Material	Plating
Contact	Brass	Silver
Insulation	PTFE	
Body	Brass	Tri-Metal
Coupling Nut	Brass	Tri-Metal
Gasket	Silicone	
Crimp Sleeve	Brass	Tri-Metal

#### Environmental Specifications

##### Temperature

Operating Range

-55 to +125 deg C

Shock

MIL-STD 202G, Meth. 204, Cond. B

Vibration

MIL-STD 202G, Meth. 213, Cond. I

Thermal Shock

MIL-STD 202G, Meth. 107, Cond. B

**Compliance Certifications** (see [product page](#) for current document)

#### Plotted and Other Data

Notes:

Click the following link (or enter part number in "SEARCH" on website) to obtain additional part information including price, inventory and certifications: [4.3-10 Male Connector Crimp/Solder Attachment for LMR-600 TC-600-4310M-X](#)



## 4.3-10 Male Connector Crimp/Solder Attachment for LMR-600

### RF Connectors Technical Data Sheet

#### Assembly Instruction

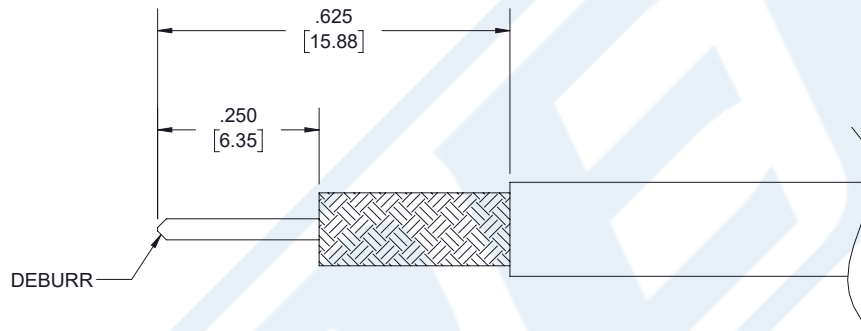

#### ASSEMBLY PROCEDURES

1. STRIP CABLE TO THE DIMENSIONS SHOWN, CHAMFER CENTER CONDUCTOR AND DEBURR CABLE.
2. SLIDE FERRULE OVER CABLE AND INSULATOR OVER CABLE CENTER CONDUCTOR. INSERT CENTER CONTACT AND SOLDER.
3. PUSH THE CONNECTOR BODY INTO THE CABLE UNTIL IT STOPS. SLIDE FERRULE FORWARD AND AGAINST SHOULDER OF CONNECTOR AND CRIMP.

#### CRIMP SIZE REQUIRED

- FERRULE: .610" [15.49] HEX CRIMP TOOL

Click the following link (or enter part number in "SEARCH" on website) to obtain additional part information including price, inventory and certifications: [4.3-10 Male Connector Crimp/Solder Attachment for LMR-600 TC-600-4310M-X](#)



## 4.3-10 Male Connector Crimp/Solder Attachment for LMR-600

### RF Connectors Technical Data Sheet



TC-600-4310M-X

4.3-10 Male Connector Crimp/Solder Attachment for LMR-600 from Pasternack Enterprises has same day shipment for domestic and International orders. Our RF, microwave and millimeter wave products maintain a 99.4% availability and are part of the broadest selection in the industry.

Click the following link (or enter part number in "SEARCH" on website) to obtain additional part information including price, inventory and certifications: [4.3-10 Male Connector Crimp/Solder Attachment for LMR-600 TC-600-4310M-X](https://www.pasternack.com/4.3-10-male-lmr-600-connector-tc-600-4310m-x-p.aspx)

URL: <https://www.pasternack.com/4.3-10-male-lmr-600-connector-tc-600-4310m-x-p.aspx>

The information contained in this document is accurate to the best of our knowledge and representative of the part described herein. It may be necessary to make modifications to the part and/or the documentation of the part, in order to implement improvements. Pasternack reserves the right to make such changes as required. Unless otherwise stated, all specifications are nominal. Pasternack does not make any representation or warranty regarding the suitability of the part described herein for any particular purpose, and Pasternack does not assume any liability arising out of the use of any part or documentation.

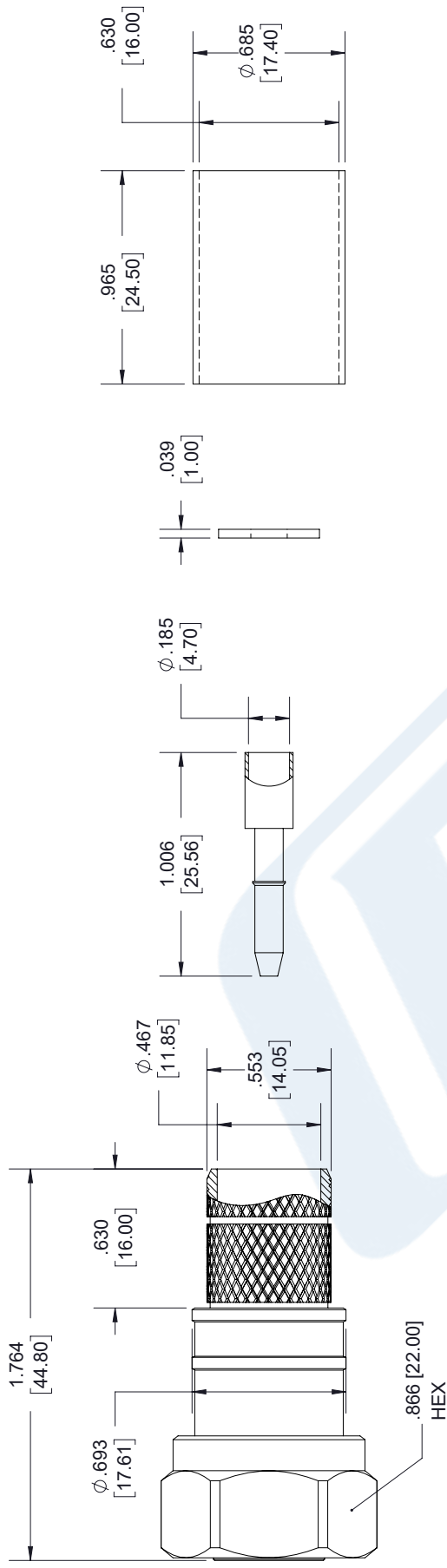

**4.3-10 MALE**

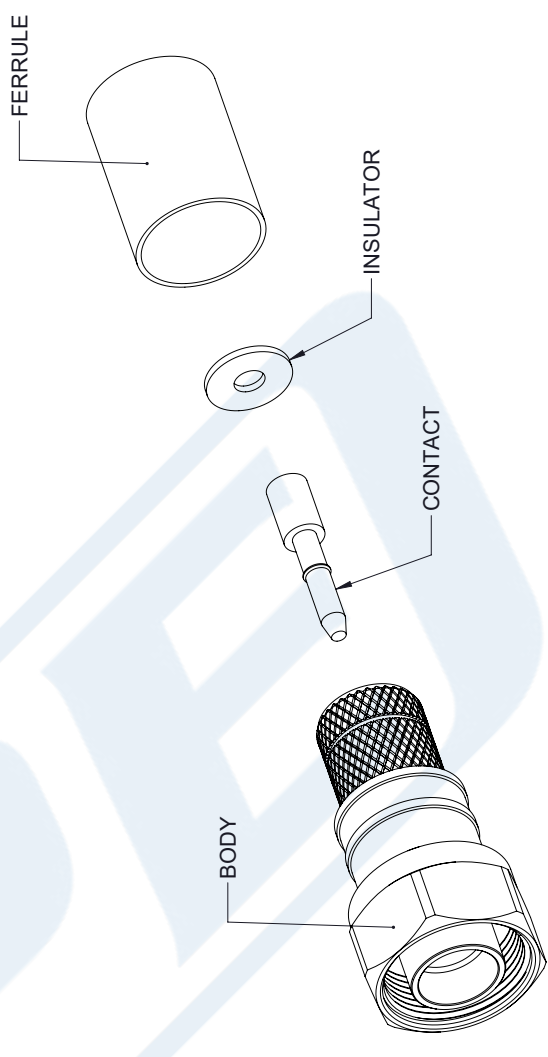

STANDARD TOLERANCES	
.X	±0.2
.XX	±0.01
.XXX	±0.005

\*STANDARD TOLERANCES APPLY ONLY TO DIMENSIONS IN INCHES



Pasternack Enterprises, Inc.  
 P.O. Box 16759 | Irvine | CA | 92623  
**Phone:** (949) 261-1920 | **Fax:** (949) 261-7451  
**Website:** www.pasternack.com | **E-Mail:** sales@pasternack.com

DWG TITLE  
**TC-600-4310M-X**

**CAGE CODE 53919**

NOTES:  
 1. UNLESS OTHERWISE SPECIFIED ALL DIMENSIONS ARE NOMINAL.  
 2. ALL SPECIFICATIONS ARE SUBJECT TO CHANGE WITHOUT NOTICE AT ANY TIME.  
 3. DIMENSIONS ARE IN INCHES [mm].

CAD FILE 04/18/18 SCALE N/A SIZE A 7361



## 4.3-10 Male Connector Crimp/Solder Attachment for LMR-600

### RF Connectors Technical Data Sheet

**TC-600-4310M-X**

### Times Microwave Systems Connector Specification

#### Configuration

- 4.3-10 Male Connector
- 50 Ohms
- Straight Body Geometry
- LMR-600 Interface Type
- Crimp/Solder Attachment

#### Features

- Max. Operating Frequency 6 GHz
- Excellent VSWR of 1.25:1
- Silver Plated Brass Contact

#### Applications

- General Purpose Test
- Custom Cable Assemblies
- Mobile Communications Systems
- Base Stations
- Distributed Antenna Systems (DAS)
- Small Cells
- Feeder Cables

#### Description

The Times Microwave TC-600-4310M-X 4.3-10 male connector with crimp/solder attachment for LMR-600 is part of our full line of RF components available for same-day shipping. This 4.3-10 male connector operates up to a maximum frequency of 6 GHz and offers good VSWR of 1.25:1.

Our datasheet specifications and drawing with dimensions for Times Microwave's 4.3-10 male connector TC-600-4310M-X are shown below in this PDF. Pasternack's broad catalog of RF, microwave and millimeter wave connectors allows designers to configure and customize their signal connections however they like. Whether the need is to provide an I/O for a board design, or simply create a custom cable assembly configuration, Pasternack has the right connector for the job. Pasternack can also expertly build your custom cable assemblies for you and ship same-day.

#### Electrical Specifications

Description	Minimum	Typical	Maximum	Units
Frequency Range	DC		6	GHz
VSWR			1.25:1	
Insulation Resistance	10,000			MOhms

Electrical Specification Notes:  
 Insertion Loss = 0.1 x SQRT(FGHz)

#### Mechanical Specifications

Mating Cycles 500 Cycles

Click the following link (or enter part number in "SEARCH" on website) to obtain additional part information including price, inventory and certifications: [4.3-10 Male Connector Crimp/Solder Attachment for LMR-600 TC-600-4310M-X](#)



## 4.3-10 Male Connector Crimp/Solder Attachment for LMR-600

### RF Connectors Technical Data Sheet



TC-600-4310M-X

#### Material Specifications

Description	Material	Plating
Contact	Brass	Silver
Insulation	PTFE	
Body	Brass	Tri-Metal
Coupling Nut	Brass	Tri-Metal
Gasket	Silicone	
Crimp Sleeve	Brass	Tri-Metal

#### Environmental Specifications

##### Temperature

Operating Range

-55 to +125 deg C

Shock

MIL-STD 202G, Meth. 204, Cond. B

Vibration

MIL-STD 202G, Meth. 213, Cond. I

Thermal Shock

MIL-STD 202G, Meth. 107, Cond. B

**Compliance Certifications** (see [product page](#) for current document)

#### Plotted and Other Data

Notes:

Click the following link (or enter part number in "SEARCH" on website) to obtain additional part information including price, inventory and certifications: [4.3-10 Male Connector Crimp/Solder Attachment for LMR-600 TC-600-4310M-X](#)



## 4.3-10 Male Connector Crimp/Solder Attachment for LMR-600

### RF Connectors Technical Data Sheet

#### Assembly Instruction

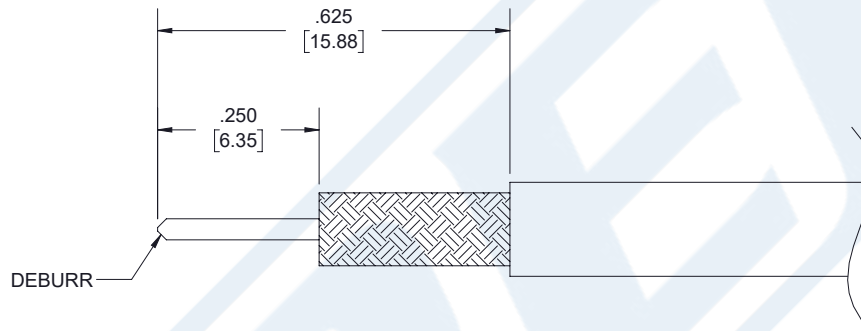

#### ASSEMBLY PROCEDURES

1. STRIP CABLE TO THE DIMENSIONS SHOWN, CHAMFER CENTER CONDUCTOR AND DEBURR CABLE.
2. SLIDE FERRULE OVER CABLE AND INSULATOR OVER CABLE CENTER CONDUCTOR. INSERT CENTER CONTACT AND SOLDER.
3. PUSH THE CONNECTOR BODY INTO THE CABLE UNTIL IT STOPS. SLIDE FERRULE FORWARD AND AGAINST SHOULDER OF CONNECTOR AND CRIMP.

#### CRIMP SIZE REQUIRED

- FERRULE: .610" [15.49] HEX CRIMP TOOL

Click the following link (or enter part number in "SEARCH" on website) to obtain additional part information including price, inventory and certifications: [4.3-10 Male Connector Crimp/Solder Attachment for LMR-600 TC-600-4310M-X](#)



## 4.3-10 Male Connector Crimp/Solder Attachment for LMR-600

### RF Connectors Technical Data Sheet



TC-600-4310M-X

4.3-10 Male Connector Crimp/Solder Attachment for LMR-600 from Pasternack Enterprises has same day shipment for domestic and International orders. Our RF, microwave and millimeter wave products maintain a 99.4% availability and are part of the broadest selection in the industry.

Click the following link (or enter part number in "SEARCH" on website) to obtain additional part information including price, inventory and certifications: [4.3-10 Male Connector Crimp/Solder Attachment for LMR-600 TC-600-4310M-X](https://www.pasternack.com/4.3-10-male-lmr-600-connector-tc-600-4310m-x-p.aspx)

URL: <https://www.pasternack.com/4.3-10-male-lmr-600-connector-tc-600-4310m-x-p.aspx>

The information contained in this document is accurate to the best of our knowledge and representative of the part described herein. It may be necessary to make modifications to the part and/or the documentation of the part, in order to implement improvements. Pasternack reserves the right to make such changes as required. Unless otherwise stated, all specifications are nominal. Pasternack does not make any representation or warranty regarding the suitability of the part described herein for any particular purpose, and Pasternack does not assume any liability arising out of the use of any part or documentation.

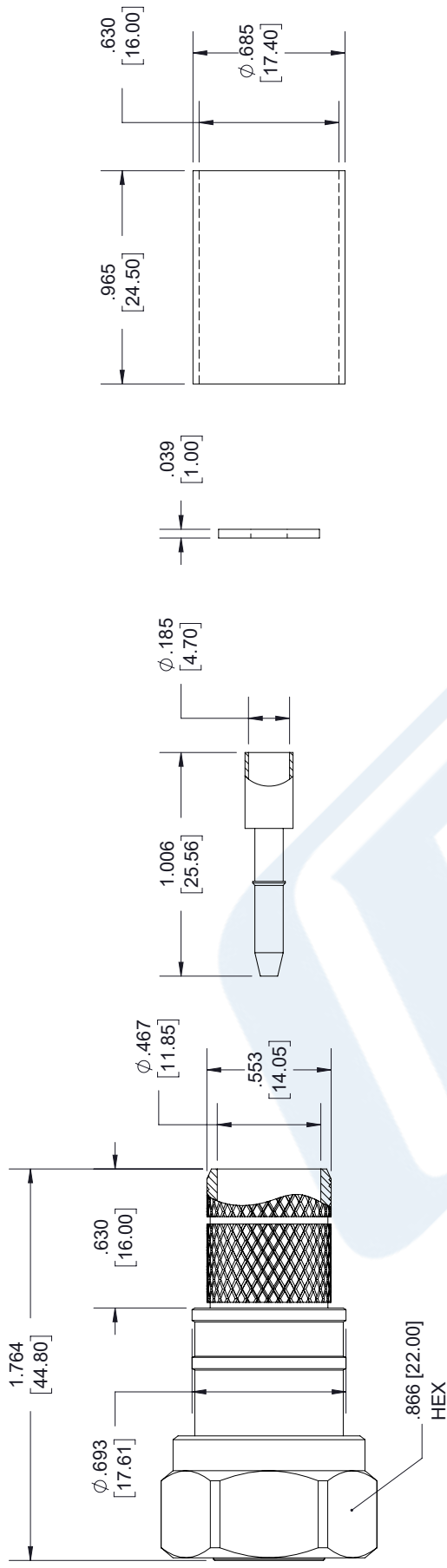

**4.3-10 MALE**

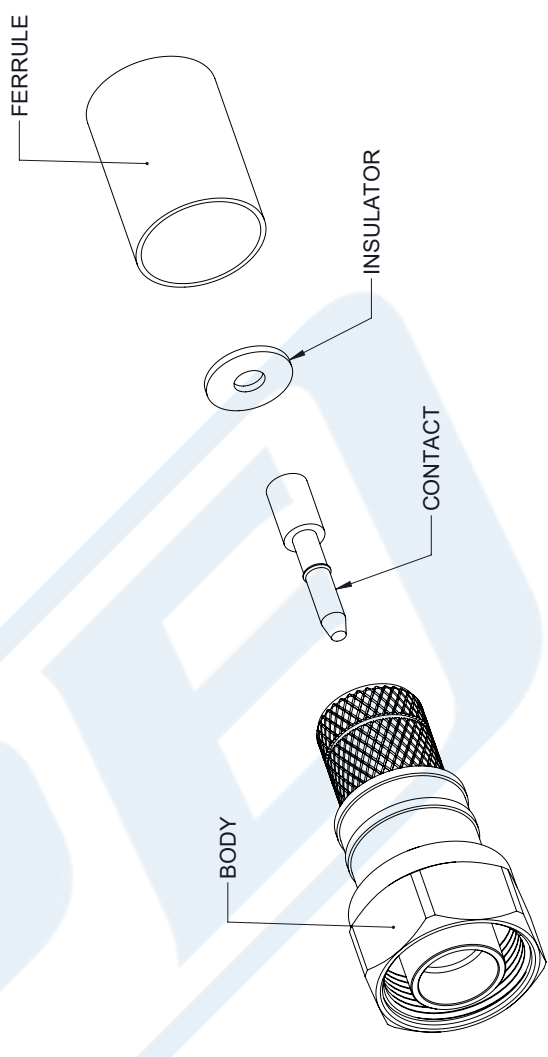

STANDARD TOLERANCES	
.X	±0.2
.XX	±0.01
.XXX	±0.005

\*STANDARD TOLERANCES APPLY ONLY TO DIMENSIONS IN INCHES



Pasternack Enterprises, Inc.  
 P.O. Box 16759 | Irvine | CA | 92623  
**Phone:** (949) 261-1920 | **Fax:** (949) 261-7451  
**Website:** www.pasternack.com | **E-Mail:** sales@pasternack.com

DWG TITLE  
**TC-600-4310M-X**

CAGE CODE **53919**

NOTES:  
 1. UNLESS OTHERWISE SPECIFIED ALL DIMENSIONS ARE NOMINAL.  
 2. ALL SPECIFICATIONS ARE SUBJECT TO CHANGE WITHOUT NOTICE AT ANY TIME.  
 3. DIMENSIONS ARE IN INCHES [mm].

CAD FILE 04/18/18

SCALE N/A

SIZE A

7361



## Low Loss Flexible .600 inch Foam Dielectric Type Coax Cable Double Shielded with Black PE Jacket

### TECHNICAL DATA SHEET

**PE-C600**

Low Loss Flexible .600 inch Foam Dielectric Type Coax Cable Double Shielded with Black PE Jacket

#### Configuration

Cable Design	Low Loss
Inner Conductor Material and Plating	Copper Clad Aluminum
Dielectric Type	PE (F)
Shield Materials	Aluminum Tape, Tinned Copper Braid
Jacket Material and Color	PE, Black

#### Electrical Specifications

Impedance, Ohms	50
Velocity of Propagation, %	87
Maximum Operating Frequency, GHz	5.8
RF Shielding, dB	90
Capacitance, pF/ft [pF/m]	23.4 [76.77]
Jacket Spark, Vrms	5,000
Peak Power, KWatts	40

#### Electrical Specifications by Frequency

##### Frequency 1

Frequency, MHz	150
Attenuation, dB/100ft [dB/100m]	1 [3.28]
Power Handling, KWatts	2.16

##### Frequency 2

Frequency, MHz	450
Attenuation, dB/100ft [dB/100m]	1.7 [5.58]
Power Handling, KWatts	1.23

##### Frequency 3

Frequency, MHz	900
Attenuation, dB/100ft [dB/100m]	2.5 [8.2]
Power Handling, Watts	840

##### Frequency 4

Frequency, GHz	1.5
Attenuation, dB/100ft [dB/100m]	3.3 [10.83]
Power Handling, Watts	630

##### Frequency 5

Frequency, GHz	1.8
Attenuation, dB/100ft [dB/100m]	3.7 [12.14]
Power Handling, Watts	570

Click the following link (or enter part number in "SEARCH" on website) to obtain additional part information including price, inventory and certifications: [Low Loss Flexible .600 inch Foam Dielectric Type Coax Cable Double Shielded with Black PE Jacket PE-C600](#)

The information contained in this document is accurate to the best of our knowledge and representative of the part described herein. It may be necessary to make modifications to the part and/or the documentation of the part, in order to implement improvements. Pasternack reserves the right to make such changes as required. Unless otherwise stated, all specifications are nominal.



## Low Loss Flexible .600 inch Foam Dielectric Type Coax Cable Double Shielded with Black PE Jacket

### TECHNICAL DATA SHEET

**PE-C600**

#### Frequency 6

Frequency, GHz	2
Attenuation, dB/100ft [dB/100m]	3.9 [12.8]
Power Handling, Watts	540

#### Frequency 7

Frequency, GHz	2.5
Attenuation, dB/100ft [dB/100m]	4.4 [14.44]
Power Handling, Watts	480

#### Frequency 8

Frequency, GHz	5.8
Attenuation, dB/100ft [dB/100m]	7.3 [23.95]
Power Handling, Watts	290

#### Mechanical Specifications

##### Temperature

Operating Range, deg C	-40 to +85
Storage Range, deg C	-40 to +85

##### Inner Conductor

Number of Strands	1
Material	Copper Clad Aluminum
Diameter, in [mm]	0.176 [4.47]

##### Dielectric:

Type	PE (F)
Diameter, in [mm]	0.455 [11.56]

##### Shield:

Number of	2
Material 1	Aluminum Tape
Material 2	Tinned Copper Braid
Diameter, in [mm]	0.49 [12.45]

##### Jacket:

Material	PE
Diameter, in [mm]	0.59 [14.99]
Color	Black
Repeated Minimum Bend Radius, in [mm]	6 [152.4]
Weight, lbs/ft [Kg/m]	0.131 [0.19]

#### Compliance Certifications (visit [www.Pasternack.com](http://www.Pasternack.com) for current document)

RoHS Compliant	Yes
----------------	-----

Click the following link (or enter part number in "SEARCH" on website) to obtain additional part information including price, inventory and certifications: [Low Loss Flexible .600 inch Foam Dielectric Type Coax Cable Double Shielded with Black PE Jacket PE-C600](#)

The information contained in this document is accurate to the best of our knowledge and representative of the part described herein. It may be necessary to make modifications to the part and/or the documentation of the part, in order to implement improvements. Pasternack reserves the right to make such changes as required. Unless otherwise stated, all specifications are nominal.



Low Loss Flexible .600 inch Foam Dielectric Type Coax  
Cable Double Shielded with Black PE Jacket

**TECHNICAL DATA SHEET**

**PE-C600**

**Plotted and Other Data**

Notes:

Values at 25 °C, sea level

URL: <http://www.pasternack.com/flexible-0.590-50-ohm-coax-cable-pe-jacket-pe-c600-p.aspx>

Low Loss Flexible .600 inch Foam Dielectric Type Coax Cable Double Shielded with Black PE Jacket from Pasternack Enterprises has same day shipment for domestic and International orders. Our RF, microwave and fiber optic products maintain a 99% availability and are part of the broadest selection in the industry.

The information contained in this document is accurate to the best of our knowledge and representative of the part described herein. It may be necessary to make modifications to the part and/or the documentation of the part, in order to implement improvements. Pasternack reserves the right to make such changes as required. Unless otherwise stated, all specifications are nominal.

# PE-C600 CAD Drawing

Low Loss Flexible .600 inch Foam Dielectric Type Coax  
Cable Double Shielded with Black PE Jacket

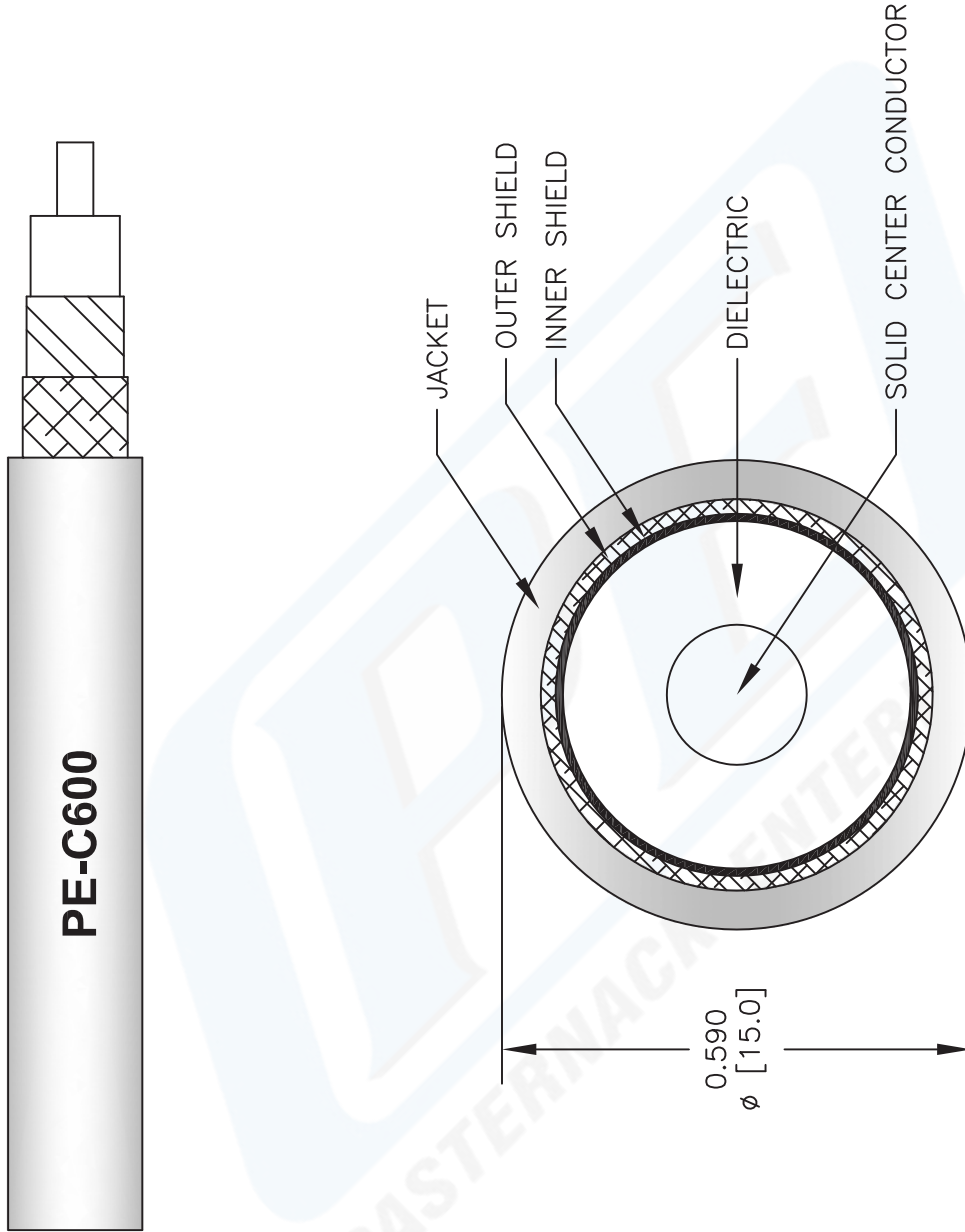

NOTES:  
 1. UNLESS OTHERWISE SPECIFIED ALL DIMENSIONS ARE NOMINAL.  
 2. ALL SPECIFICATIONS ARE SUBJECT TO CHANGE WITHOUT NOTICE AT ANY TIME.  
 3. DIMENSIONS ARE IN INCHES [mm].

DWG TITLE  
**PE-C600**

FSCM NO. 53919

CAD FILE 042809

SCALE N/A

SIZE A

2233

**PE PASTERNAK®**  
 Pasternack Enterprises, Inc.  
 P.O. Box 16759 | Irvine | CA | 92623  
**Phone:** (949) 261-1920 | **Fax:** (949) 261-7451  
**Website:** www.pasternack.com | **E-Mail:** sales@pasternack.com