

**NOTICE OF PROPRIETARY RIGHTS** THIS DOCUMENT CONTAINS CONFIDENTIAL TECHNICAL DATA, INCLUDING TRADE SECRETS, PROPRIETARY TO TIMES MICROWAVE SYSTEMS. DISCLOSURE OF THIS DATA IS EXPRESSLY CONDITIONED UPON YOUR ASSENT THAT ITS USE IS LIMITED TO USE WITHIN YOUR COMPANY ONLY. ANY OTHER USE IS STRICTLY PROHIBITED WITHOUT THE PRIOR WRITTEN CONSENT OF TIMES MICROWAVE SYSTEMS.

SYM	REVISION DESCRIPTION	DFTM	DATE	APPD	DATE
A	RELEASED FOR PRODUCTION	K.A.M.	5/20/11	J.D.B.	6/9/11



Reference standard IEC60169-16

**I. Electric Performance**

Nominal Impedance( $\Omega$ ):	50
Frequency Range:	DC-6GHz
VSWR:	$\leq 1.35$
Insert Loss:	$\leq 0.10$ (0-3G)
Insulation resistance ( $M\Omega$ )	$> 5000$
Proof voltage (V)	2500
Conductor resistance ( $m\Omega$ )	outer conductor $< 0.4$ inner conductor $< 0.8$

**II. Mechanical Performance**

Whorl pull	500N
Nut torque	5N.m
Tensile force(cable-connect)	400N
Torsion(cable-connect)	2N.m

**III. Material and plating :**

Component	Material	Plating
inner conductor	Beryllium copper	Au $> 1.27\mu m$
outer conductor	Brass	Copper-tin-zinc $> 2\mu m$
insulator	PTFE	
nut	Brass	Copper-tin-zinc $> 2\mu m$

**IV. Environment**

Temp.range	-55 $^{\circ}C$ ~+155 $^{\circ}C$
Weather standard	IEC 60068 55 / 155/ 56
Thermal shock	US MIL-STD 202,Meth.107,Cond.B
Vibration	US MIL-STD 202,Meth.204,Cond.B
Shock	US MIL-STD 202,Meth.213,Cond.I
Waterproof standard	IP67
ROHS compliant	

MATERIAL:	UNLESS OTHERWISE SPECIFIED		DFTM: K. A. M.	TIMES MICROWAVE SYSTEMS			
	ALL DIMENSIONS ARE IN mm		DATE: 5/20/11				
USED ON:			CHKD: J. D. B.	CONNECTOR, NM FOR LMR-400 (EZ-400-NMC-2-D)			
			DATE: 6/9/11				
			APPD: J. D. B.				
SCALE: ~	DWG. SIZE: A	DO NOT SCALE DRAWING	CODE IDENT: 68999	DATE: 6/9/11	SHEET: 1 of 1	SD3190-2640	REV: A

**NOTICE OF PROPRIETARY RIGHTS** THIS DOCUMENT CONTAINS CONFIDENTIAL TECHNICAL DATA, INCLUDING TRADE SECRETS, PROPRIETARY TO TIMES MICROWAVE SYSTEMS. DISCLOSURE OF THIS DATA IS EXPRESSLY CONDITIONED UPON YOUR ASSENT THAT ITS USE IS LIMITED TO USE WITHIN YOUR COMPANY ONLY. ANY OTHER USE IS STRICTLY PROHIBITED WITHOUT THE PRIOR WRITTEN CONSENT OF TIMES MICROWAVE SYSTEMS.

SYM	REVISION DESCRIPTION	DFTM	DATE	APPD	DATE
A	RELEASED FOR PRODUCTION	K.A.M.	5/20/11	J.D.B.	6/9/11

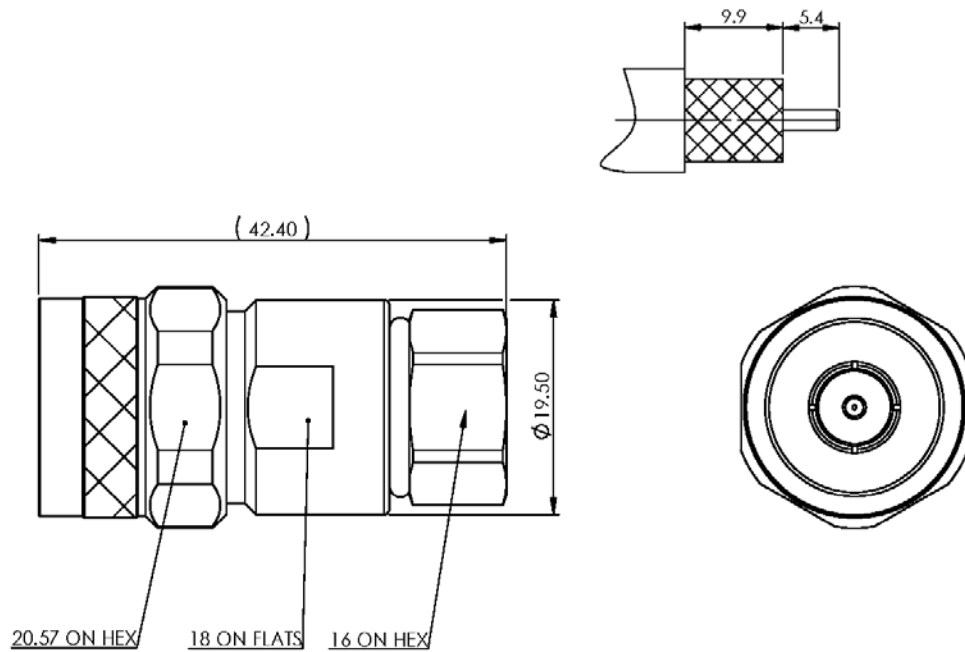

Reference standard IEC60169-16

I. Electric Performance

Nominal Impedance( $\Omega$ ):	50
Frequency Range:	DC-6GHz
VSWR:	$\leq 1.35$
Insert Loss:	$\leq 0.10$ (0-3G)
Insulation resistance ( $M\Omega$ )	$> 5000$
Proof voltage (V)	2500
Conductor resistance ( $m\Omega$ )	outer conductor $< 0.4$ inner conductor $< 0.8$

II. Mechanical Performance

Whorl pull	500N
Nut torque	5N.m
Tensile force(cable-connect)	400N
Torsion(cable-connect)	2N.m

III. Material and plating :

Component	Material	Plating
inner conductor	Beryllium copper	Au $> 1.27\mu m$
outer conductor	Brass	Copper-tin-zinc $> 2\mu m$
insulator	PTFE	
nut	Brass	Copper-tin-zinc $> 2\mu m$

IV. Environment

Temp.range	-55 $^{\circ}C$ ~+155 $^{\circ}C$
Weather standard	IEC 60068 55 / 155/ 56
Thermal shock	US MIL-STD 202,Meth.107,Cond.B
Vibration	US MIL-STD 202,Meth.204,Cond.B
Shock	US MIL-STD 202,Meth.213,Cond.I
Waterproof standard	IP67
ROHS compliant	

MATERIAL:	UNLESS OTHERWISE SPECIFIED		DFTM: K. A. M.	TIMES MICROWAVE SYSTEMS			
	ALL DIMENSIONS ARE IN mm		DATE: 5/20/11				
USED ON:			CHKD: J. D. B.	CONNECTOR, NM FOR LMR-400 (EZ-400-NMC-2-D)			
			DATE: 6/9/11				
			APPD: J. D. B.				
SCALE: ~	DWG. SIZE: A	DO NOT SCALE DRAWING	CODE IDENT: 68999	DATE: 6/9/11	SHEET: 1 of 1	SD3190-2640	REV: A



## LMR-LW400 Light weight version of the 400 series Low Loss Coax

### Times Microwave Systems Coax Cable Specification

#### Configuration

- Low Loss, Outdoor Flexible Cable
- 2 Shield(s)

#### Features

- Light Weight Coax with Aluminum Shielding
- Max Operating Frequency of 8 GHz
- Phase Velocity 84% VoP
- Max Operating Temperature +85°C
- PE Jacket
- Min Install Bend Radius of 1 inches

#### Applications

- Antenna Installs
- RF Test Systems
- General Purpose RF Interconnect
- Laboratory Applications

#### Description

LMR-LW400 Light weight version of the 400 series Low Loss Coax from Times Microwave is part of the large product offering by Pasternack of radio frequency coaxial cable types specifically stocked to be ready for same-day shipment. Pasternack LMR-LW400 coax cable is manufactured in a flexible design and has a 50 Ohm impedance. This low loss and light weight flexible 50 Ohm coax cable LMR-LW400 is constructed with a 0.405 inch diameter and Black PE jacket.

LMR-LW400 flexible 50 Ohm coax cable with PE jacket is rated for a 8 GHz maximum operating frequency. This 50 Ohm 0.405 inch diameter and low loss flexible coax cable is built with an aluminum double shield count and RF shielding of 90 dB. Times Microwave LMR-LW400 PE coax is constructed with Foam PE dielectric and a maximum operating temperature of 85 degrees C. Pasternack's offering of LMR-LW400 coax cable provides specs for this wire on its RF coax cable LMR-LW400 datasheet.

LMR-LW400 cable is part of more than one million RF, microwave parts in stock at Pasternack. This Times Microwave low loss and light weight LMR-LW400 coax cable is ready to buy and can be shipped worldwide. Pasternack also maintains a wide selection of other radio frequency coaxial cable types that ship same-day from our warehouse as with the rest of our other RF/microwave components.

\* LMR™ is a trademark of Times Microwave Systems.

#### Electrical Specifications

Description	Minimum	Typical	Maximum	Units
Frequency Range	DC		8	GHz
Impedance		50		Ohms
Velocity of Propagation		84		%
Time Delay		1.2 [3.94]		ns/ft [ns/m]
Shielding Effectiveness	90			dB
Dielectric Withstanding Voltage (DC)			2,500	Vdc
Jacket Spark			8,000	Vrms

Click the following link (or enter part number in "SEARCH" on website) to obtain additional part information including price, inventory and certifications: [LMR-LW400 Light weight version of the 400 series Low Loss Coax LMR-LW400](#)



## LMR-LW400 Light weight version of the 400 series Low Loss Coax

### RF Cables Technical Data Sheet



LMR-LW400

Inner Conductor DC Resistance	1.39	Ohms/1000ft
Outer Conductor DC Resistance	6.1	Ohms/1000ft
Nominal Capacitance	23.9 [78.41]	pF/ft [pF/m]
Nominal Inductance	0.06 [0.2]	uH/ft [uH/m]
Input Power (Peak)	16	kWatts

#### Performance by Frequency Band

Description	F1	F2	F3	F4	F5	Units
Frequency	0.05	0.15	0.45	0.9	1.5	GHz
Attenuation, Typ	0.9	1.5	2.7	3.9	5.1	dB/100ft
	2.95	4.92	8.86	12.8	16.73	dB/100m
Input Power (CW), Max	2,570	1,470	830	580	440	Watts

Description	F6	F7	F8	F9	F10	Units
Frequency	1.8	2	2.5	5.8	8	GHz
Attenuation, Typ	5.7	6	6.8	10.8	13	dB/100ft
	18.7	19.69	22.31	35.43	42.65	dB/100m
Input Power (CW), Max	400	370	330	210	170	Watts

#### Mechanical Specifications

Diameter	0.405 in [10.29 mm]
Weight	0.05 lbs/ft [0.07 kg/m]
Min. Bend Radius (Installation)	1 in [25.4 mm]
Min. Bend Radius (Repeated)	4 in [101.6 mm]
Bending Moment	0.5 lbs-ft [0.68 N-m]
Tensile Strength	160 lbs [72.57 kg]
Flat Plate Crush	40 lbs/in [0.71 kg/mm]

#### Construction Specifications

Description	Material and Plating	Diameter
Inner Conductor	Copper, 1 Strand	0.108 in [2.74 mm]
Conductor Type	Solid	

Click the following link (or enter part number in "SEARCH" on website) to obtain additional part information including price, inventory and certifications: [LMR-LW400 Light weight version of the 400 series Low Loss Coax LMR-LW400](#)



## LMR-LW400 Light weight version of the 400 series Low Loss Coax

### RF Cables Technical Data Sheet



LMR-LW400

Dielectric	Foam PE	0.285 in [7.24 mm]
First Shield	Aluminum Tape	[ ]
Second Shield	Aluminium	[ ]
Jacket	PE, Black	0.405 in [10.29 mm]

#### Environmental Specifications

##### Temperature

Operating Range	-40 to +85 deg C
Installation Range	-40 to +85 deg C
Storage Range	-70 to +85 deg C

#### Compliance Certifications (see [product page](#) for current document)

#### Plotted and Other Data

Notes:

LMR-LW400 Light weight version of the 400 series Low Loss Coax from Pasternack Enterprises has same day shipment for domestic and International orders. Our RF, microwave and millimeter wave products maintain a 99.4% availability and are part of the broadest selection in the industry.

Click the following link (or enter part number in "SEARCH" on website) to obtain additional part information including price, inventory and certifications: [LMR-LW400 Light weight version of the 400 series Low Loss Coax LMR-LW400](#)

URL: <https://www.pasternack.com/low-loss-flexible-lmr-lw400-pe-jacket-aluminum-tape-over-aluminium-outer-conductor-double-shielded-lmr-lw400-p.aspx>

The information contained in this document is accurate to the best of our knowledge and representative of the part described herein. It may be necessary to make modifications to the part and/or the documentation of the part, in order to implement improvements. Pasternack reserves the right to make such changes as required. Unless otherwise stated, all specifications are nominal. Pasternack does not make any representation or warranty regarding the suitability of the part described herein for any particular purpose, and Pasternack does not assume any liability arising out of the use of any part or documentation.

REVISIONS		
REV.	DESCRIPTION	DATE
A	INITIAL RELEASE	06-04-2021
		APPROVED
		SELLIS

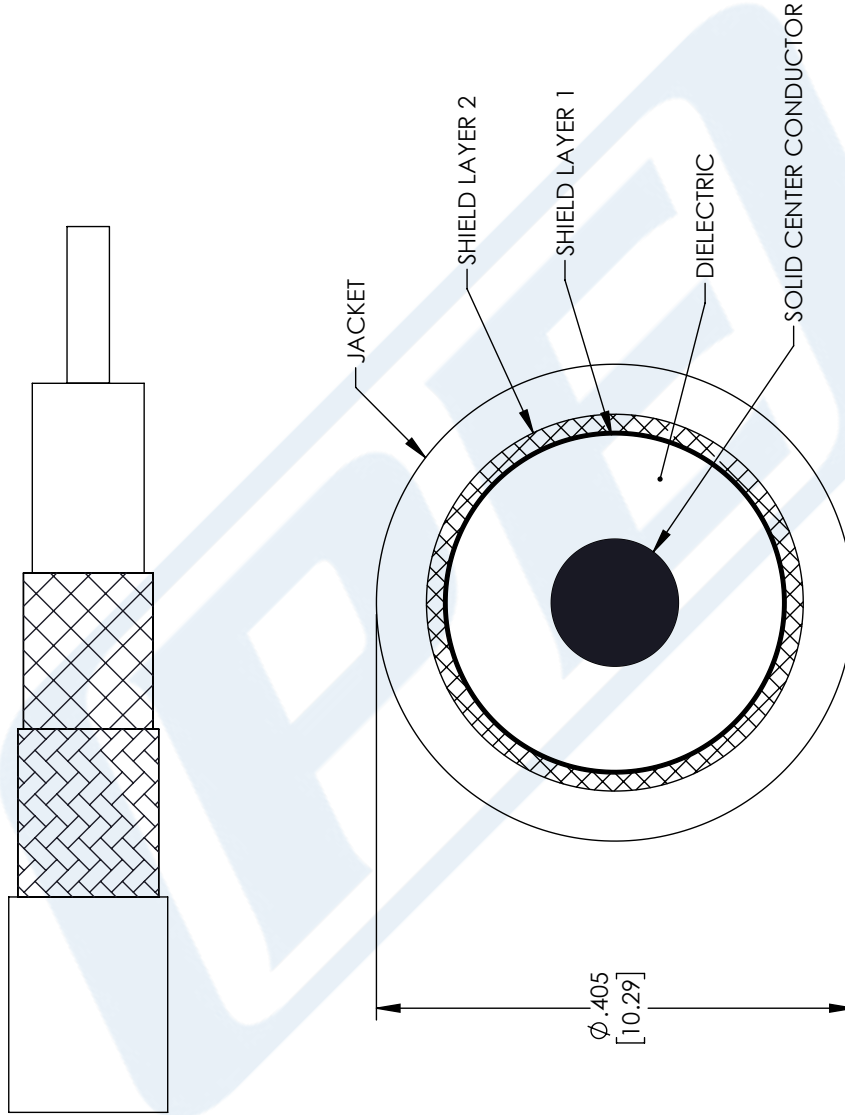

UNLESS OTHERWISE SPECIFIED  
 LEADING DIMENSIONS ARE INCHES  
 DIMENSIONS IN [ ] ARE MILLIMETERS

**TOLERANCES:**

.X = ±.2 [ .008]    FRACTIONS    ± 1/32  
 .XX = ±.02 [ .51]    ± 1/32  
 .XXX = ±.005 [ .13]    ANGLES ± 1°

**CABLE LENGTH (L) TOLERANCES:**

L ≤ 12 [305] = +1 [25] / -0  
 12 [305] < L ≤ 60 [1524] = +2 [51] / -0  
 60 [1524] < L ≤ 120 [3048] = +4 [102] / -0  
 120 [3048] < L ≤ 300 [7620] = +6 [152] / -0  
 300 [7620] < L = +5% / -0

ALL DIMENSIONS SHOWN  
 ARE FOR REFERENCE ONLY.

**PE PASTERNAK**  
 an INFINITI brand

Pasternack Enterprises, Inc.  
 P. O. Box 16759, Irvine, CA 92623.  
 Phone: 1.949.261.1920 | 1.866.727.8376  
 Fax: 1.949.261.7451  
 Website: www.pasternack.com  
 E-mail: sales@pasternack.com

ITEM NO. LMR-LW400  
 DRAWN BY MVEERAPPAN  
 SIZE A  
 CAGE CODE 53919

THIRD-ANGLE PROJECTION

THE INFORMATION AND  
 DESIGN IN THIS DOCUMENT  
 IS THE PROPERTY OF  
 PASTERNAK CORPORATION  
 ALL RIGHTS RESERVED.

SHEET 1 OF 1  
 SCALE N/A  
 REV A