

NOTICE OF PROPRIETARY RIGHTS THIS DOCUMENT CONTAINS CONFIDENTIAL TECHNICAL DATA, INCLUDING TRADE SECRETS, PROPRIETARY TO TIMES MICROWAVE SYSTEMS. DISCLOSURE OF THIS DATA IS EXPRESSLY CONDITIONED UPON YOUR ASSENT THAT ITS USE IS LIMITED TO USE WITHIN YOUR COMPANY ONLY. ANY OTHER USE IS STRICTLY PROHIBITED WITHOUT THE PRIOR WRITTEN CONSENT OF TIMES MICROWAVE SYSTEMS.

SYM	REVISION DESCRIPTION	DFTM	DATE	APPD	DATE
A	RELEASED FOR PRODUCTION	K.A.M.	5/23/11	J.D.B.	6/9/11
B	CHANGED PER CDC #37302	D.J.H.	3/22/13	J.D.B.	3/25/13

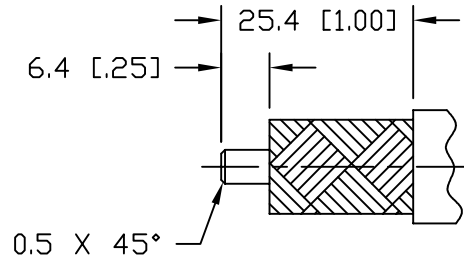

CABLE PREP.
USE CST-600
(3192-052)
.610" HEX.

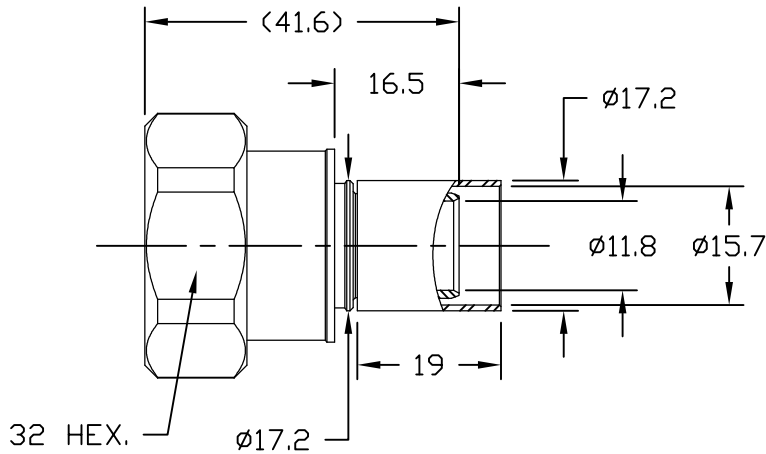

Reference Standard IEC60169-4

I. Electric Performance

Nominal Impedance(Ω):	50
Frequency Range:	DC-3GHz
VSWR:	≤ 1.15
Insert Loss(dB):	≤ 0.05
Insulation resistance(M Ω):	≥ 10000
Proof Voltage(V)	2500
Conductor resistance(m Ω)	outer conductor <0.2 inner conductor <0.8

II. Mechanical Performance

Nut Torque	25N.m
(Nut)Whorl pull	1000N
Tensile force(cable-connect)	500N
Torsion(cable-connect)	5N.m

III. Material and plating

Component	Material	Plating
Inner conductor	Spring Copper	Ag 5 μ m
Outer conductor	Brass	Copper-tin-zinc 2 μ m
Tube	Copper	Copper-tin-zinc 2 μ m
Nut	Brass	Nickel 5 μ m
Gasket	Silicone Rubber	
Insulator	PTFE	

IV. Environment

Temp. range	-55 $^{\circ}$ C~+155 $^{\circ}$ C
Weather standard	IEC 60068 55 / 155/ 56
Thermal shock	US MIL-STD 202,Meth.107,Cond.B
Vibration	US MIL-STD 202,Meth.204,Cond.B
Shock	US MIL-STD 202,Meth.213,Cond.I
Waterproofing standard	IP68
ROHS Compliant	

V. Assembly: inner conductor installed and outer conductor crimped

MATL:	UNLESS OTHERWISE SPECIFIED	DFTM. K. A. M.	TIMES MICROWAVE SYSTEMS
	ALL DIMENSIONS ARE IN mm MACHINED SURFACES FINISH N/A RMS MAX. REMOVE ALL BURRS N/A MAX. BREAK MACHINE CORNERS N/A MAX. FILLET R. TOLERANCES ON DECIMALS .XX \pm N/A .XXX \pm N/A ANGLES \pm 1 $^{\circ}$ FRACTIONS \pm N/A	DATE 5/23/11	
USED ON: 0-0	DO NOT SCALE DRAWING	CHKD. J. D. B.	EZ-600-716M-X 7-16 MALE FOR LMR-600 CABLE EZ/CRIMP/NO BRAID TRIM
		DATE 6/9/11	
SCALE: N/A	DWG. SIZE A	APPD. J. D. B.	SHEET 1 of 1 SD3190-2643 REV B
	CODE IDENT 68999	DATE 6/9/11	

Installation Instruction

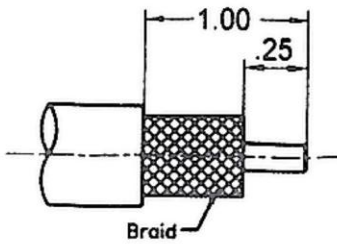

1. A. Trim cable to dimensions shown. Be careful to avoid nicking the braid
B. Remove any residual plastic from center conductor
C. Deburr center conductor using a fine file or Times DBT-U tools
D. Avoid nicking aluminum tape or center conductor

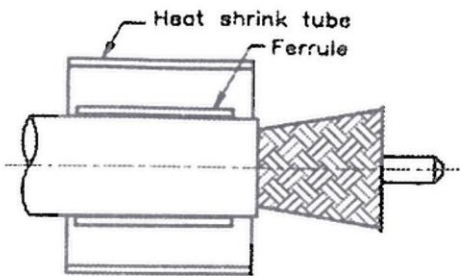

2. A. Slide crimp ferrule and heat shrink tube over the cable
B. Flare the braid

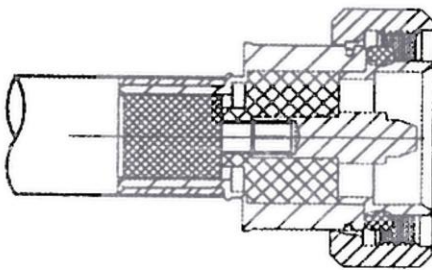

3. A. Insert Cable into connector body until dielectric is seated and center conductor is inserted fully into connector center pin.

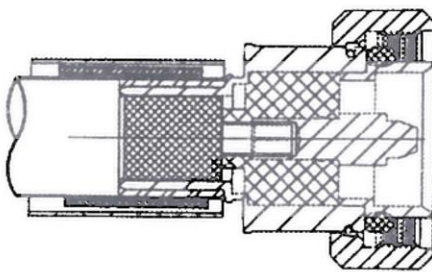

4. A. Slide crimp ferrule over braid and crimp as close to body as possible using .429" HEX crimp tooling. Pay attention to the crimp area, do not crimp rear of crimp sleeve
B. Heat shrink tube over rear of connector body and down on to cable jacket using hot air gun

NOTICE OF PROPRIETARY RIGHTS THIS DOCUMENT CONTAINS CONFIDENTIAL TECHNICAL DATA, INCLUDING TRADE SECRETS, PROPRIETARY TO TIMES MICROWAVE SYSTEMS. DISCLOSURE OF THIS DATA IS EXPRESSLY CONDITIONED UPON YOUR ASSENT THAT ITS USE IS LIMITED TO USE WITHIN YOUR COMPANY ONLY. ANY OTHER USE IS STRICTLY PROHIBITED WITHOUT THE PRIOR WRITTEN CONSENT OF TIMES MICROWAVE SYSTEMS.

SYM	REVISION DESCRIPTION	DFTM	DATE	APPD	DATE
A	RELEASED FOR PRODUCTION	K.A.M.	5/23/11	J.D.B.	6/9/11
B	CHANGED PER CDC #37302	D.J.H.	3/22/13	J.D.B.	3/25/13

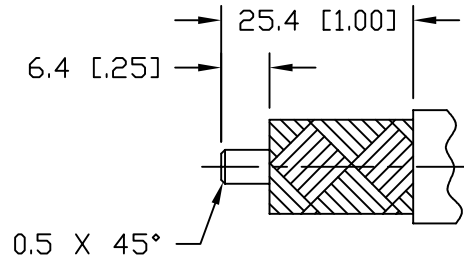

CABLE PREP.
USE CST-600
(3192-052)
.610" HEX.

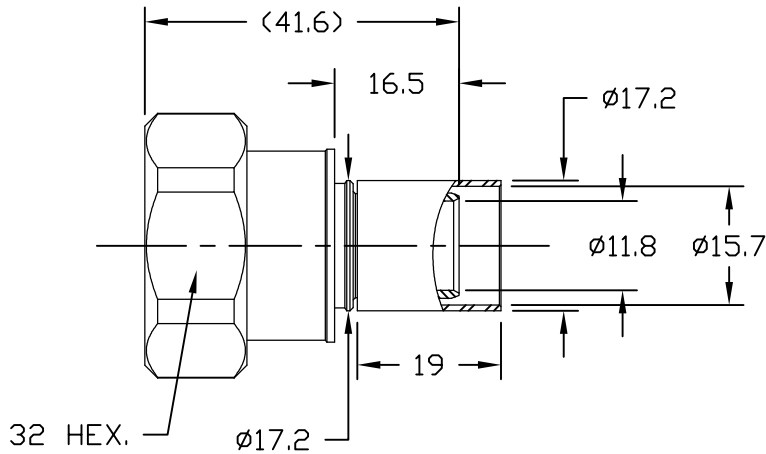

Reference Standard IEC60169-4

I. Electric Performance

Nominal Impedance(Ω):	50
Frequency Range:	DC-3GHz
VSWR:	≤ 1.15
Insert Loss(dB):	≤ 0.05
Insulation resistance(M Ω)	≥ 10000
Proof Voltage(V)	2500
Conductor resistance(m Ω)	outer conductor <0.2 inner conductor <0.8

II. Mechanical Performance

Nut Torque	25N.m
(Nut)Whorl pull	1000N
Tensile force(cable-connect)	500N
Torsion(cable-connect)	5N.m

III. Material and plating

Component	Material	Plating
Inner conductor	Spring Copper	Ag 5 μ m
Outer conductor	Brass	Copper-tin-zinc 2 μ m
Tube	Copper	Copper-tin-zinc 2 μ m
Nut	Brass	Nickel 5 μ m
Gasket	Silicone Rubber	
Insulator	PTFE	

IV. Environment

Temp. range	-55°C~+155°C
Weather standard	IEC 60068 55 / 155/ 56
Thermal shock	US MIL-STD 202,Meth.107,Cond.B
Vibration	US MIL-STD 202,Meth.204,Cond.B
Shock	US MIL-STD 202,Meth.213,Cond.I
Waterproofing standard	IP68
ROHS Compliant	

V. Assembly: inner conductor installed and outer conductor crimped

MATL:	UNLESS OTHERWISE SPECIFIED		DFTM. K. A. M.	TIMES MICROWAVE SYSTEMS
	ALL DIMENSIONS ARE IN mm MACHINED SURFACES FINISH N/A RMS MAX. REMOVE ALL BURRS N/A MAX. BREAK MACHINE CORNERS N/A MAX. FILLET R. TOLERANCES ON DECIMALS .XX \pm N/A .XXX \pm N/A ANGLES \pm 1° FRACTIONS \pm N/A		DATE 5/23/11	
USED ON: 0-0	DO NOT SCALE DRAWING		CHKD. J. D. B.	EZ-600-716M-X 7-16 MALE FOR LMR-600 CABLE EZ/CRIMP/NO BRAID TRIM
			DATE 6/9/11	
SCALE: N/A	DWG. SIZE: A	CODE IDENT: 68999	APPD. J. D. B.	DATE 6/9/11
			DATE 6/9/11	SH 1 of 1 SD3190-2643 REV B

Installation Instruction

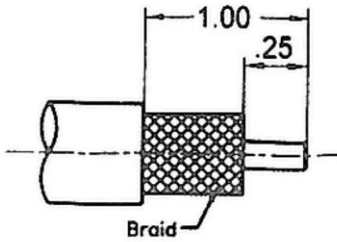

1. A. Trim cable to dimensions shown. Be careful to avoid nicking the braid
B. Remove any residual plastic from center conductor
C. Deburr center conductor using a fine file or Times DBT-U tools
D. Avoid nicking aluminum tape or center conductor

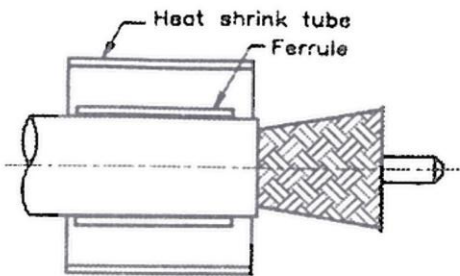

2. A. Slide crimp ferrule and heat shrink tube over the cable
B. Flare the braid

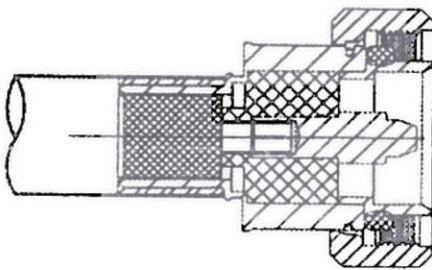

3. A. Insert Cable into connector body until dielectric is seated and center conductor is inserted fully into connector center pin.

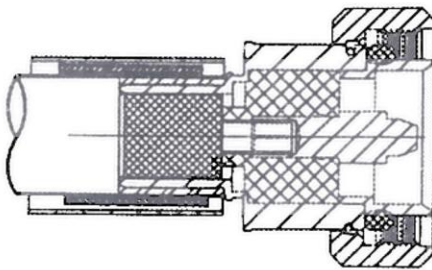

4. A. Slide crimp ferrule over braid and crimp as close to body as possible using .429" HEX crimp tooling. Pay attention to the crimp area, do not crimp rear of crimp sleeve
B. Heat shrink tube over rear of connector body and down on to cable jacket using hot air gun



Low Loss Flexible LMR-600-UF Outdoor Rated Coax Cable Double Shielded with Black TPE Jacket Ultra Flex

RF Cables Technical Data Sheet



LMR-600-UF

Times Microwave Systems Coax Cable Specification

Configuration

- Low Loss, Outdoor Flexible Cable
- 2 Shield(s)

Features

- Ultra Flexible Coax with Stranded Center Conductor
- Max Operating Frequency of 5.8 GHz
- Phase Velocity 87% VoP
- Max Operating Temperature +85°C
- TPE Jacket
- Min Install Bend Radius of 1.5 inches

Applications

- RF Test Systems
- Antenna Installs
- Laboratory Applications
- General Purpose RF Interconnect
- Jumper Assemblies

Description

LMR-600-UF Ultra Flex version of the 600 series Low Loss Coax from Times Microwave is part of the large product offering by Pasternack of radio frequency coaxial cable types specifically stocked to be ready for same-day shipment. Pasternack LMR-600-UF coax cable is manufactured in an ultra flexible design and has a 50 Ohm impedance. This low loss and ultra flexible 50 Ohm coax cable LMR-600-UF is constructed with a 0.590 inch diameter and Black TPE jacket.

LMR-600-UF flexible 50 Ohm coax cable with TPE jacket is rated for a 5.8 GHz maximum operating frequency. This 50 Ohm 0.590 inch diameter and low loss ultra flexible coax cable is built with an aluminum double shield count and RF shielding of 90 dB. Times Microwave LMR-600-UF TPE coax is constructed with Foam PE dielectric and a maximum operating temperature of 85 degrees C. Pasternack's offering of LMR-600-UF coax cable provides specs for this wire on its RF coax cable LMR-600-UF datasheet.

LMR-600-UF cable is part of more than one million RF, microwave parts in stock at Pasternack. This Times Microwave low loss ultra flexible LMR-600-UF coax cable is ready to buy and can be shipped worldwide. Pasternack also maintains a wide selection of other radio frequency coaxial cable types that ship same-day from our warehouse as with the rest of our other RF/microwave components.

* LMR™ is a trademark of Times Microwave Systems.

Electrical Specifications

Description	Minimum	Typical	Maximum	Units
Frequency Range	DC		5.8	GHz
Impedance		50		Ohms
Velocity of Propagation		87		%
Time Delay		1.17 3.84		ns/ft ns/m
Shielding Effectiveness	90			dB
Dielectric Withstanding Voltage (DC)			4,000	Vdc

Click the following link (or enter part number in "SEARCH" on website) to obtain additional part information including price, inventory and certifications: [Low Loss Flexible LMR-600-UF Outdoor Rated Coax Cable Double Shielded with Black TPE Jacket Ultra Flex LMR-600-UF](#)



Low Loss Flexible LMR-600-UF Outdoor Rated Coax Cable Double Shielded with Black TPE Jacket Ultra Flex

RF Cables Technical Data Sheet



LMR-600-UF

Jacket Spark	8,000	Vrms
Inner Conductor DC Resistance	0.43	Ohms/1000ft
Outer Conductor DC Resistance	1.2	Ohms/1000ft
Nominal Capacitance	23.4 [76.77]	pF/ft [pF/m]
Nominal Inductance	0.058 [0.19]	uH/ft [uH/m]
Input Power (Peak)	40	kWatts

Performance by Frequency Band

Description	F1	F2	F3	F4	F5	Units
Frequency	50	150	220	450	900	MHz
Attenuation, Typ	0.7	1.2	1.4	2.1	3	dB/100ft
	2.3	3.94	4.59	6.89	9.84	dB/100m
Input Power (CW), Max	3,530	2,000	1,640	1,120	770	Watts

Description	F6	F7	F8	F9	F10	Units
Frequency	1.5	1.8	2	2.5	5.8	GHz
Attenuation, Typ	4	4.4	4.7	5.3	8.7	dB/100ft
	13.12	14.44	15.42	17.39	28.54	dB/100m
Input Power (CW), Max	580	520	490	430	260	Watts

Mechanical Specifications

Diameter	0.59 in [14.99 mm]
Weight	0.165 lbs/ft [0.25 Kg/m]
Min. Bend Radius (Installation)	1.5 in [38.1 mm]
Min. Bend Radius (Repeated)	6 in [152.4 mm]
Bending Moment	1.75 lbs-ft [2.37 N-m]
Tensile Strength	350 lbs [158.76 kg]
Flat Plate Crush	40 lbs/in [0.71 Kg/mm]

Construction Specifications

Description	Material and Plating	Diameter
Inner Conductor	Copper, 1 Strand	0.176 in [4.47 mm]

Click the following link (or enter part number in "SEARCH" on website) to obtain additional part information including price, inventory and certifications: [Low Loss Flexible LMR-600-UF Outdoor Rated Coax Cable Double Shielded with Black TPE Jacket Ultra Flex LMR-600-UF](#)



Low Loss Flexible LMR-600-UF Outdoor Rated Coax Cable
Double Shielded with Black TPE Jacket Ultra Flex

RF Cables
Technical Data Sheet



LMR-600-UF

Conductor Type	Stranded	
Dielectric	Foam PE	0.455 in [11.56 mm]
First Shield	Aluminum Tape	[]
Second Shield	Tinned Copper	[]
Jacket	TPE, Black	0.59 in [14.99 mm]

Environmental Specifications

Temperature

Operating Range	-40 to +85 deg C
Installation Range	-40 to +85 deg C
Storage Range	-70 to +85 deg C

Environmental Specification Notes:
Indoor/Outdoor

Compliance Certifications (see [product page](#) for current document)

Plotted and Other Data

Notes:

Low Loss Flexible LMR-600-UF Outdoor Rated Coax Cable Double Shielded with Black TPE Jacket Ultra Flex from Pasternack Enterprises has same day shipment for domestic and International orders. Our RF, microwave and millimeter wave products maintain a 99.4% availability and are part of the broadest selection in the industry.

Click the following link (or enter part number in "SEARCH" on website) to obtain additional part information including price, inventory and certifications: [Low Loss Flexible LMR-600-UF Outdoor Rated Coax Cable Double Shielded with Black TPE Jacket Ultra Flex LMR-600-UF](#)

URL: <https://www.pasternack.com/low-loss-flexible-lmr-600-uf-tpe-jacket-aluminum-tape-over-tinned-copper-outer-conductor-double-shielded-lmr-600-uf-p.aspx>

The information contained in this document is accurate to the best of our knowledge and representative of the part described herein. It may be necessary to make modifications to the part and/or the documentation of the part, in order to implement improvements. Pasternack reserves the right to make such changes as required. Unless otherwise stated, all specifications are nominal. Pasternack does not make any representation or warranty regarding the suitability of the part described herein for any particular purpose, and Pasternack does not assume any liability arising out of the use of any part or documentation.

TIMES MICROWAVE SYSTEMS **LMR-600-UF CAD Drawing**
 Low Loss Flexible LMR-600-UF Outdoor Rated Coax Cable
 Double Shielded with Black TPE Jacket Ultra Flex

REVISIONS		
REV.	DESCRIPTION	DATE
A	INITIAL RELEASE	06-04-2021
		APPROVED
		SELLIS

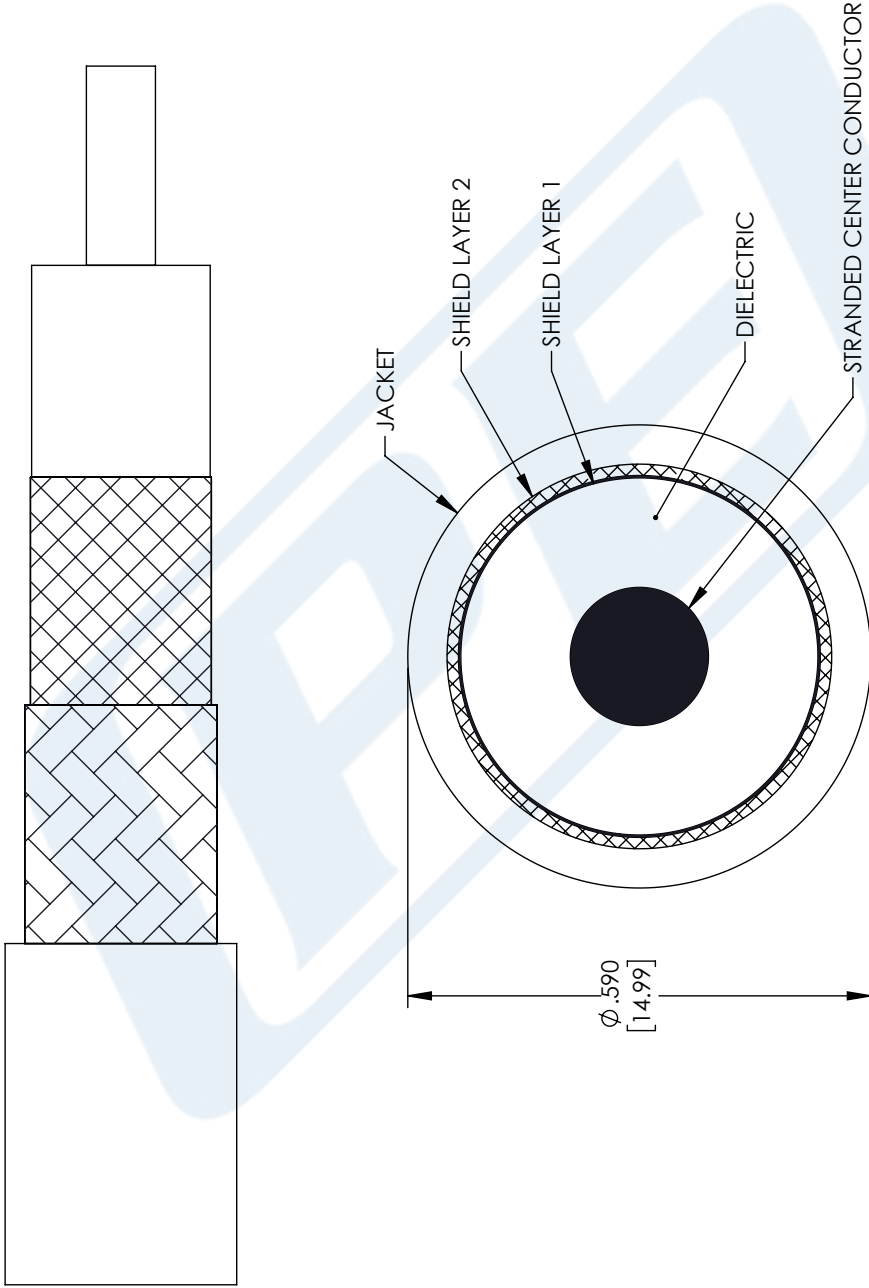

UNLESS OTHERWISE SPECIFIED
 LEADING DIMENSIONS ARE INCHES
 DIMENSIONS IN [] ARE MILLIMETERS

TOLERANCES:
 .X = ±.2 [.008] FRACTIONS ± 1/32
 .XX = ±.02 [.51] ANGLES ± 1°
 .XXX = ±.005 [.13]

CABLE LENGTH (L), TOLERANCES:
 L ≤ 12 [305] = +1 [25] / -0
 12 [305] < L ≤ 60 [1524] = +2 [51] / -0
 60 [1524] < L ≤ 120 [3048] = +4 [102] / -0
 120 [3048] < L ≤ 300 [7620] = +6 [152] / -0
 300 [7620] < L = +5%L / -0

ALL DIMENSIONS SHOWN
 ARE FOR REFERENCE ONLY.

PE PASTERNAK
 an INFINITI brand

Pasternack Enterprises, Inc.
 P. O. Box 16759, Irvine, CA 92623.
 Phone: 1.949.261.1920 | 1.866.727.8376
 Fax: 1.949.261.7451
 Website: www.pasternack.com
 E-mail: sales@pasternack.com

SIZE [CAGE CODE] DRAWN BY ITEM NO.
 A 53919 MVEERAPPAN LMR-600-UF

THIRD-ANGLE PROJECTION

THE INFORMATION AND DESIGN IN THIS DOCUMENT IS THE PROPERTY OF PASTERNAK CORPORATION ALL RIGHTS RESERVED.

SHEET 1 OF 1

SCALE N/A

REV A

THESE COMMODITIES, TECHNOLOGY OR SOFTWARE WERE EXPORTED FROM THE UNITED STATES IN ACCORDANCE WITH THE EXPORT ADMINISTRATION REGULATIONS. DIVERSION CONTRARY TO U.S. LAW PROHIBITED.