

<b>MATERIALS</b>	
BODY	BRASS NICKEL PLATED
CONTACT	GOLD PLATED
INSULATOR	PTFE

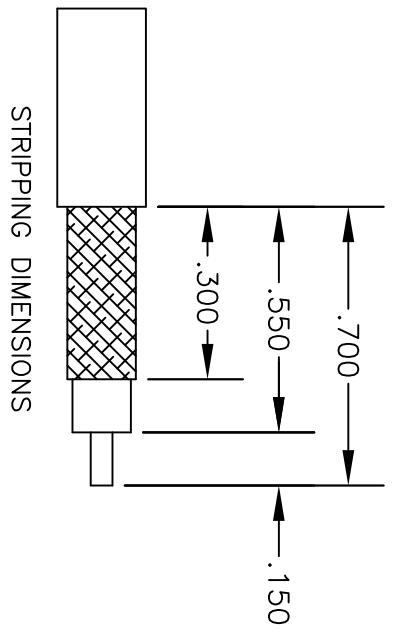

CRIMP SIZES REQUIRED  
 CONTACT: .100" HEX CRIMP TOOL  
 FERRULE: .213" HEX CRIMP TOOL

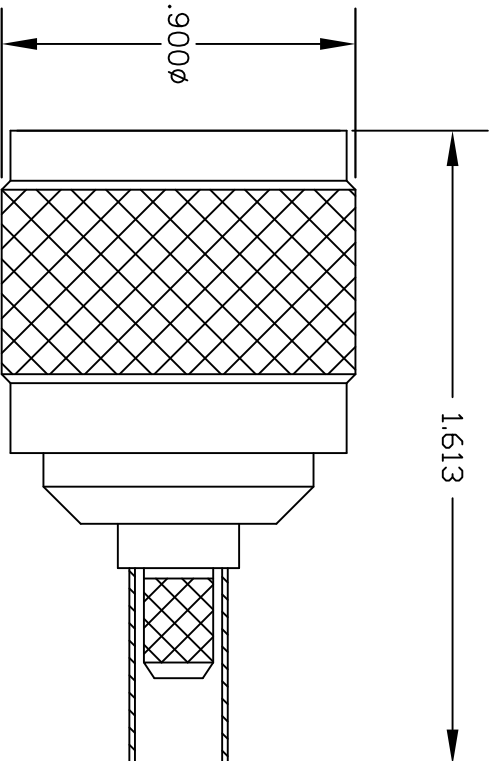

**PASTERNAK ENTERPRISES, INC.**  
 P.O. BOX 16759, IRVINE, CA 92623  
 PHONE (949) 261-1920 FAX (949) 261-7451  
 WEB ADDRESS: [www.pasternack.com](http://www.pasternack.com)  
 E-MAIL ADDRESS: [sales@pasternack.com](mailto:sales@pasternack.com)  
**COAXIAL & FIBER OPTICS**

DWG TITLE  
**PE4478**

DES. HN MALE, CRIMP ATTACHMENT FOR RG58

SIZE A	FSCM NO. 53919	CAD FILE	051602	SCALE	N/A		127
--------	----------------	----------	--------	-------	-----	--	-----

NOTES:  
 1. UNLESS OTHERWISE SPECIFIED ALL DIMENSIONS ARE NOMINAL.  
 2. ALL SPECIFICATIONS ARE SUBJECT TO CHANGE WITHOUT NOTICE AT ANY TIME.

<b>MATERIALS</b>	
BODY	BRASS NICKEL PLATED
CONTACT	GOLD PLATED
INSULATOR	PTFE

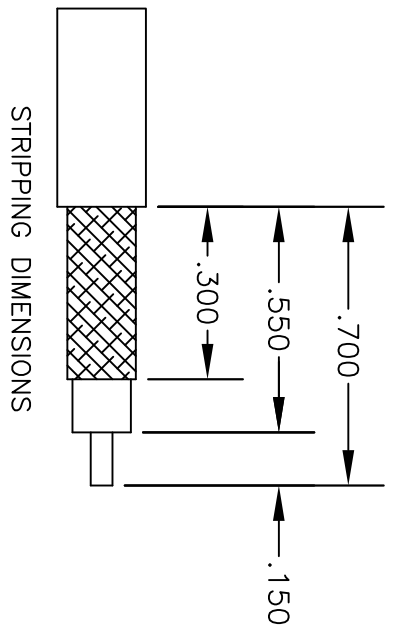
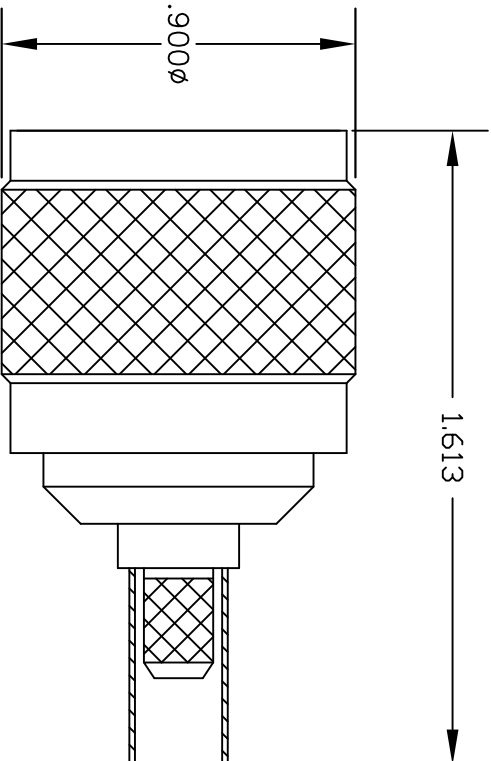

CRIMP SIZES REQUIRED  
 CONTACT: .100" HEX CRIMP TOOL  
 FERRULE: .213" HEX CRIMP TOOL



**PASTERNAK ENTERPRISES, INC.**  
 P.O. BOX 16759, IRVINE, CA 92623  
 PHONE (949) 261-1920 FAX (949) 261-7451  
 WEB ADDRESS: [www.pasternack.com](http://www.pasternack.com)  
 E-MAIL ADDRESS: [sales@pasternack.com](mailto:sales@pasternack.com)  
**COAXIAL & FIBER OPTICS**

DWG TITLE  
**PE4478**

DES. HN MALE, CRIMP ATTACHMENT FOR RG58

SIZE A	FSCM NO. 53919	CAD FILE	051602	SCALE	N/A		127
--------	----------------	----------	--------	-------	-----	--	-----

NOTES:  
 1. UNLESS OTHERWISE SPECIFIED ALL DIMENSIONS ARE NOMINAL.  
 2. ALL SPECIFICATIONS ARE SUBJECT TO CHANGE WITHOUT NOTICE AT ANY TIME.



## Flexible RG303 Coax Cable Single Shielded with Tan FEP Jacket

### TECHNICAL DATA SHEET

RG303/U

#### Flexible RG303 Coax Cable Single Shielded with Tan FEP Jacket

##### Configuration

Inner Conductor Material and Plating	Copper Clad Steel, Silver
Dielectric Type	PTFE
Shield Materials	Silver Plated Copper Braid
Jacket Material and Color	FEP, Tan

##### Electrical Specifications

Impedance, Ohms	50
Maximum Operating Frequency, GHz	3
Capacitance, pF/ft [pF/m]	32 [104.99]
Dielectric Withstanding Voltage, Vrms	5,000

##### Electrical Specifications by Frequency

###### Frequency 1

Frequency, MHz	400
Attenuation, dB/100ft [dB/100m]	8.6 [28.22]

##### Mechanical Specifications

###### Inner Conductor

Number of Strands	1
Material	Copper Clad Steel
Plating	Silver
Diameter, in [mm]	0.037 [0.94]

###### Dielectric:

Type	PTFE
Diameter, in [mm]	0.116 [2.95]

###### Shield:

Number of	1
Material 1	Silver Plated Copper Braid
Diameter, in [mm]	0.146 [3.71]

###### Jacket:

Material	FEP
Diameter, in [mm]	0.17 [4.32]
Color	Tan
Weight, lbs/ft [Kg/m]	0.039 [0.06]

Click the following link (or enter part number in "SEARCH" on website) to obtain additional part information including price, inventory and certifications: [Flexible RG303 Coax Cable Single Shielded with Tan FEP Jacket RG303/U](#)

The information contained in this document is accurate to the best of our knowledge and representative of the part described herein. It may be necessary to make modifications to the part and/or the documentation of the part, in order to implement improvements. Pasternack reserves the right to make such changes as required. Unless otherwise stated, all specifications are nominal.



## Flexible RG303 Coax Cable Single Shielded with Tan FEP Jacket

### TECHNICAL DATA SHEET

RG303/U

**Compliance Certifications** (visit [www.Pasternack.com](http://www.Pasternack.com) for current document)

RoHS Compliant

Yes

**Plotted and Other Data**

Notes:

Values at 25 °C, sea level

Flexible RG303 Coax Cable Single Shielded with Tan FEP Jacket from Pasternack Enterprises has same day shipment for domestic and International orders. Our RF, microwave and fiber optic products maintain a 99% availability and are part of the broadest selection in the industry.

Click the following link (or enter part number in "SEARCH" on website) to obtain additional part information including price, inventory and certifications: [Flexible RG303 Coax Cable Single Shielded with Tan FEP Jacket RG303/U](#)

URL: <http://www.pasternack.com/flexible-0.170-rg303-50-ohm-coax-cable-fep-jacket-rg303-u-p.aspx>

The information contained in this document is accurate to the best of our knowledge and representative of the part described herein. It may be necessary to make modifications to the part and/or the documentation of the part, in order to implement improvements. Pasternack reserves the right to make such changes as required. Unless otherwise stated, all specifications are nominal.

# RG303/U CAD Drawing

Flexible RG303 Coax Cable Single Shielded with Tan FEP Jacket

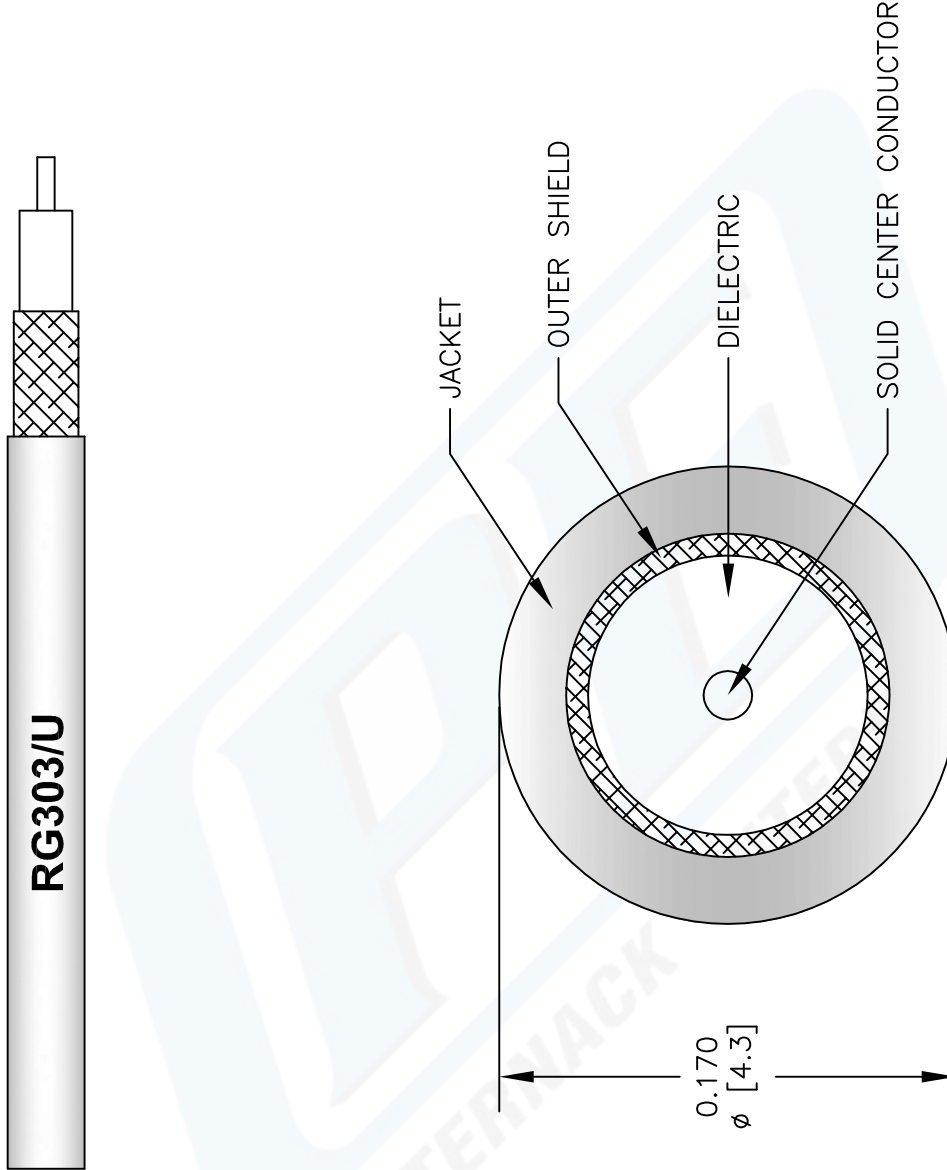

NOTES:  
 1. UNLESS OTHERWISE SPECIFIED ALL DIMENSIONS ARE NOMINAL.  
 2. ALL SPECIFICATIONS ARE SUBJECT TO CHANGE WITHOUT NOTICE AT ANY TIME.  
 3. DIMENSIONS ARE IN INCHES (mm).

DWG TITLE  
**RG303/U**

REV. A FSCM NO. 53919  
 CAD FILE 022908-A  
 SCALE N/A  
 SIZE A  
 147

**PE PASTERNAK®**  
 Pasternack Enterprises, Inc.  
 P.O. Box 16759 | Irvine | CA | 92623  
 Phone: (949) 261-1920 | Fax: (949) 261-7451  
 Website: www.pasternack.com | E-Mail: sales@pasternack.com