

NOTICE OF PROPRIETARY RIGHTS THIS DOCUMENT CONTAINS CONFIDENTIAL TECHNICAL DATA, INCLUDING TRADE SECRETS, PROPRIETARY TO TIMES MICROWAVE SYSTEMS. DISCLOSURE OF THIS DATA IS EXPRESSLY CONDITIONED UPON YOUR ASSENT THAT ITS USE IS LIMITED TO USE WITHIN YOUR COMPANY ONLY. ANY OTHER USE IS STRICTLY PROHIBITED WITHOUT THE PRIOR WRITTEN CONSENT OF TIMES MICROWAVE SYSTEMS.

SYM	REVISION DESCRIPTION	DFTM	DATE	APPD	DATE
A	RELEASED FOR PRODUCTION	K.A.M.	2/25/10	J.D.B.	3/11/10
B	CHANGED PER CDC #34322	D.J.H.	10/12/11	J.D.B.	10/27/11
C	CHANGED PER CDC #36607	D.J.H.	11/16/12	J.D.B.	11/19/12

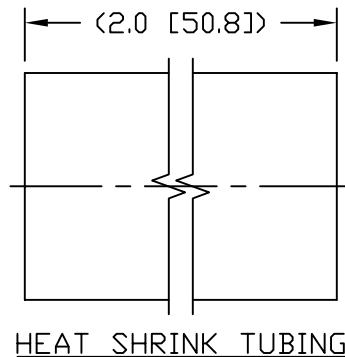

HEAT SHRINK TUBING

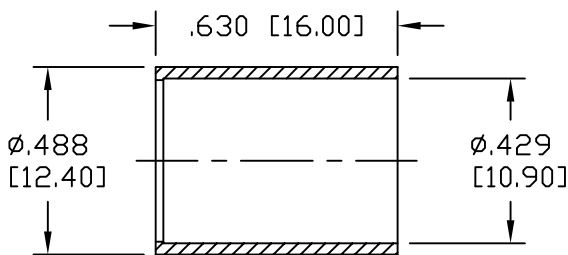
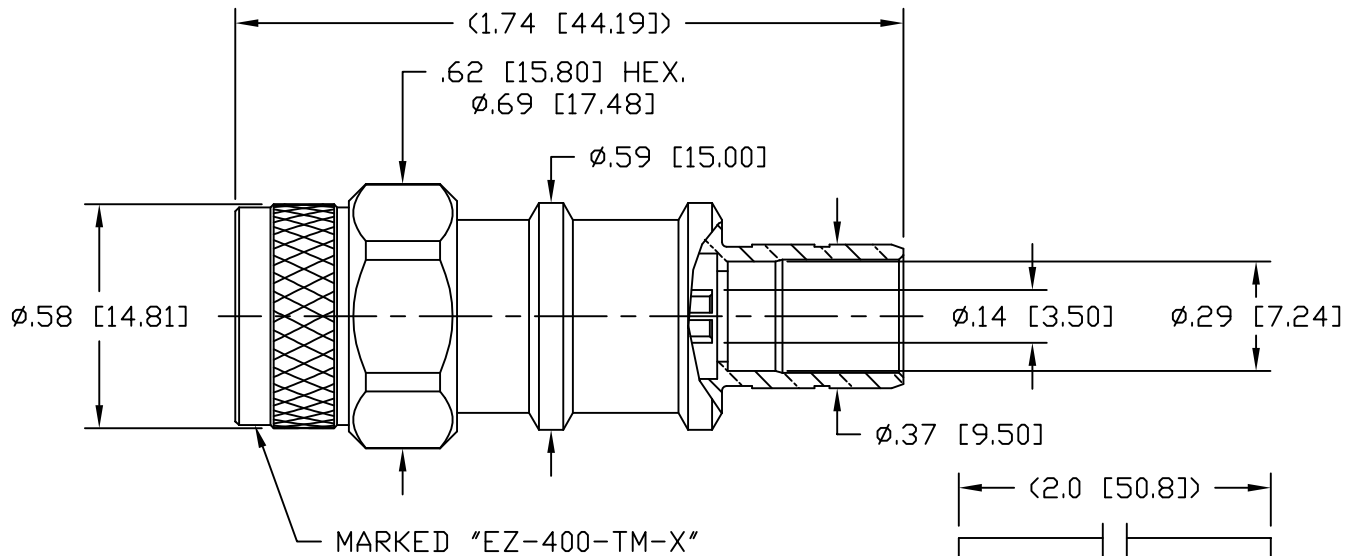
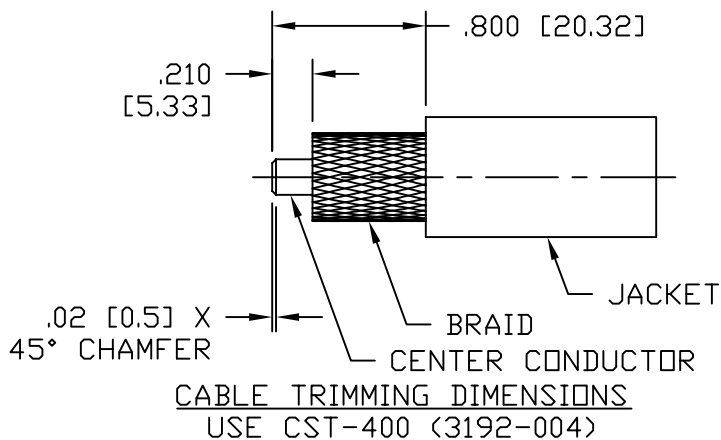

CABLE TRIMMING DIMENSIONS
USE CST-400 (3192-004)

NOTES:

- MATERIALS AND FINISHES:**
BODY: BRASS, ALBALOY PLATING
COUPLING NUT: BRASS, ALBALOY PLATING
CENTER CONTACT: BERYLLIUM COPPER, GOLD PLATING
FERRULE: COPPER, ALBALOY PLATING
- ELECTRICAL:**
IMPEDANCE: 50 OHMS NOMINAL
FREQUENCY: DC-6 GHz
VSWR: 1.2 DC-6 GHz
DIELECTRIC WITHSTANDING VOLTAGE: 1,000 VOLTS RMS
- MECHANICAL:**
DURABILITY: 500 CYCLES MIN.
TEMPERATURE RANGE: -65°C TO +165°C
- CABLING INSTRUCTIONS:**
A. SLIDE FERRULE OVER CABLE JACKET
B. TRIM CABLE TO DIMENSIONS SHOWN. MAKE SURE CUTS ARE SHARP AND SQUARE. DO NOT NICK BRAID OR CENTER CONDUCTOR.
C. FLAIR BRAID SLIGHTLY AND INSERT CABLE INTO BODY UNTIL BOTTOMED. SLIDE THE FERRULE UP THE CABLE AND OVER THE BRAID UNTIL BOTTOMED ON BODY. CRIMP FERRULE USING A .429 HEX.
5. RECOMMENDED COUPLING NUT TORQUE: 4-6 IN-LBS.

MATERIAL:	UNLESS OTHERWISE SPECIFIED ALL DIMENSIONS ARE IN INCHES MACHINED SURFACES FINISH 32 RMS MAX. REMOVE ALL BURRS .005 MAX. BREAK MACHINE CORNERS .005 MAX. FILLET R. TOLERANCES ON DECIMALS .XX ± .01 .XXX ± .005 ANGLES ± 1° FRACTIONS ± 1/64	DFTM: K. A. M.	TIMES MICROWAVE SYSTEMS
		DATE: 2/25/10	
USED ON: B		CHKD: J. D. B.	EZ-400-TM-X PLUG, TNC, EZ FOR LMR-400
		DATE: 3/11/10	
SCALE: ~	DWG. SIZE: A	APPD: J. D. B.	SHEET: 1 of 1
		DATE: 3/11/10	
DO NOT SCALE DRAWING	CODE IDENT: 68999	DATE: 3/11/10	REV: C



TNC Female Connector Solder Attachment for LMR-400, LMR-400-DB, LMR-400-UF, PE-B400, PE-B405, PE-C400

RF Connectors Technical Data Sheet

PE45639

Configuration

- TNC Female Connector
- 50 Ohms
- Straight Body Geometry
- Connector Interface Types: LMR-400, LMR-400-DB, LMR-400-UF, PE-B400, PE-B405, PE-C400

Features

- Max. Operating Frequency 6 GHz
- Excellent VSWR of 1.2:1
- Gold Plated Brass Contact

Applications

- General Purpose Test
- Custom Cable Assemblies

Description

Pasternack's PE45639 TNC female connector with solder attachment for LMR-400, LMR-400-DB, LMR-400-UF, PE-B400, PE-B405 and PE-C400 is part of our full line of RF components available for same-day shipping. Our TNC female connector operates up to a maximum frequency of 6 GHz and offers excellent VSWR of 1.2:1.

Our TNC female connector PE45639 datasheet specifications and drawing with dimensions are shown below in this PDF. Pasternack's broad catalog of RF, microwave and millimeter wave connectors allows designers to configure and customize their signal connections however they like. Whether the need is to provide an I/O for a board design, or simply create a custom cable assembly configuration, Pasternack has the right connector for the job. Pasternack can also expertly build your custom cable assemblies for you and ship same-day.

Electrical Specifications

Description	Minimum	Typical	Maximum	Units
Frequency Range	DC		6	GHz
VSWR			1.2:1	
Insertion Loss			0.2	dB
Operating Voltage (DC)			500	Vdc
Dielectric Withstanding Voltage (AC)			1,500	Vrms
Dielectric Withstanding Voltage (DC)			1,500	Vdc

Mechanical Specifications

Size

Length	1.11 in [28.19 mm]
Width/Dia.	0.56 in [14.22 mm]
Weight	0.5 lbs [226.8 g]
Mating Cycles	500 Cycles

Click the following link (or enter part number in "SEARCH" on website) to obtain additional part information including price, inventory and certifications: [TNC Female Connector Solder Attachment for LMR-400, LMR-400-DB, LMR-400-UF, PE-B400, PE-B405, PE-C400 PE45639](#)



TNC Female Connector Solder Attachment for LMR-400, LMR-400-DB, LMR-400-UF, PE-B400, PE-B405, PE-C400

RF Connectors
Technical Data Sheet

PE45639

Material Specifications

Description	Material	Plating
Contact	Brass	Gold
Insulation	PTFE	
Body	Brass	Nickel
Crimp Sleeve	Brass	Nickel

Environmental Specifications

Temperature

Operating Range	-55 to +85 deg C
Humidity	MIL-Std. 202 Method 106
Vibration	MIL-Std. 202 Method 204 (Test Condition D)
Altitude	MIL-Std. 202 Method 105 (Test Condition C)
Temperature Cycle	MIL-Std. 202 Method 102 (Test Condition D)
Salt Spray	MIL-Std. 202 Method 101 (Test Condition B)

Compliance Certifications (see [product page](#) for current document)

Plotted and Other Data

Notes:

TNC Female Connector Solder Attachment for LMR-400, LMR-400-DB, LMR-400-UF, PE-B400, PE-B405, PE-C400 from Pasternack Enterprises has same day shipment for domestic and International orders. Our RF, microwave and millimeter wave products maintain a 99.4% availability and are part of the broadest selection in the industry.

Click the following link (or enter part number in "SEARCH" on website) to obtain additional part information including price, inventory and certifications: [TNC Female Connector Solder Attachment for LMR-400, LMR-400-DB, LMR-400-UF, PE-B400, PE-B405, PE-C400 PE45639](#)

URL: <https://www.pasternack.com/tnc-female-lmr-400-lmr-400-db-connector-pe45639-p.aspx>

The information contained in this document is accurate to the best of our knowledge and representative of the part described herein. It may be necessary to make modifications to the part and/or the documentation of the part, in order to implement improvements. Pasternack reserves the right to make such changes as required. Unless otherwise stated, all specifications are nominal. Pasternack does not make any representation or warranty regarding the suitability of the part described herein for any particular purpose, and Pasternack does not assume any liability arising out of the use of any part or documentation.

PE45639 CAD Drawing

TNC Female Connector Solder Attachment for LMR-400, LMR-400-DB, LMR-400-UF, PE-B400, PE-B405, PE-C400

REVISIONS		
REV.	DESCRIPTION	DATE
A	INITIAL RELEASE	9/11/2020
		APPROVED
		S. ELLIS

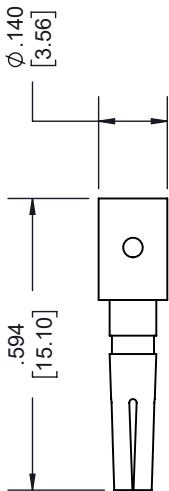
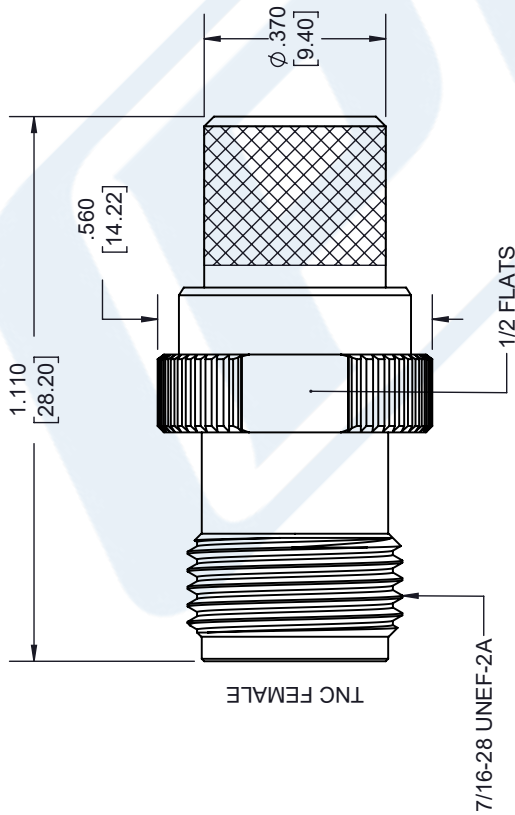
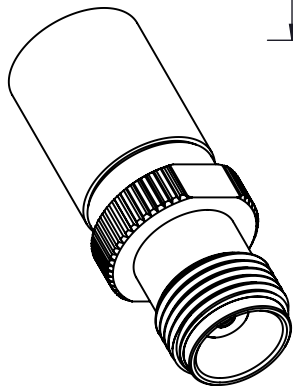

CONTACT

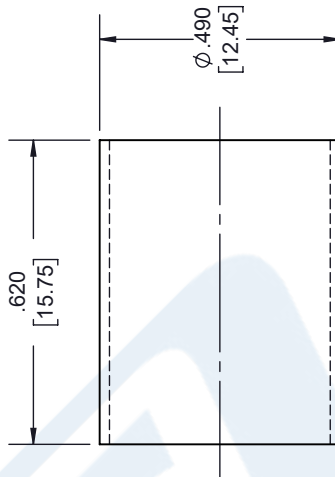

FERRULE

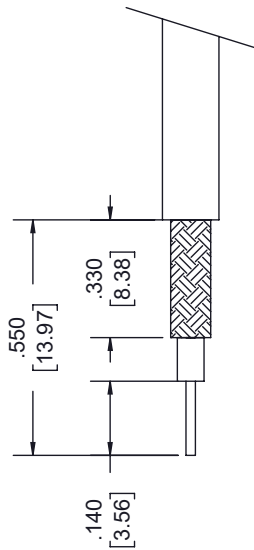

STRIPPING DIMENSIONS

- NOTES:
- CABLE ATTACHMENT:
 - OUTER: CRIMP.
 - INNER: SOLDER.
 - CRIMP SIZE REQUIRED:
 - FERRULE: .429 [10.90] HEX. CRIMP TOOL.
 - CONTACT: SOLDER.

UNLESS OTHERWISE SPECIFIED LEADING DIMENSIONS ARE INCHES DIMENSIONS IN [] ARE MILLIMETERS

TOLERANCES:
 .X = ±.2 [5.08] | FRACTIONS ± 1/32
 .XX = ±.02 [.51] | ANGLES ± 1°
 .XXX = ±.005 [.13]
 CABLE LENGTH (L), TOLERANCES:
 L ≤ 12 [305] = +1 [25] / -0
 12 [305] < L ≤ 60 [1524] = +2 [51] / -0
 60 [1524] < L ≤ 120 [3048] = +4 [102] / -0
 120 [3048] < L ≤ 300 [7620] = +6 [152] / -0
 300 [7620] < L = +5% / -0

ALL DIMENSIONS SHOWN ARE FOR REFERENCE ONLY.

THIRD-ANGLE PROJECTION

THE INFORMATION AND DESIGN IN THIS DOCUMENT IS THE PROPERTY OF PASTERNAK CORPORATION ALL RIGHTS RESERVED.

SHEET 1 OF 1

SCALE N/A

PE PASTERNAK
 an INFINITE brand

Pasternack Enterprises, Inc.
 P. O. Box 16759, Irvine, CA 92623.
 Phone: 1.949.261.1920 | 1.866.727.8376
 Fax: 1.949.261.7451
 Website: www.pasternack.com
 E-mail: sales@pasternack.com

ITEM NO. PE45639

DRAWN BY K.DANG

SIZE A

CAGE CODE 53919



LMR-400-FR Fire Rated version of the 400 series Low Loss Coax

Times Microwave Systems Coax Cable Specification

Configuration

- Low Loss, Outdoor Flexible Cable
- 2 Shield(s)

Features

- CMR Riser Rated Coax
- Non-Halogen, Low Smoke FRPE Jacket
- Max Operating Frequency of 5.8 GHz
- Phase Velocity 84% VoP
- Max Operating Temperature +85°C
- Min Install Bend Radius of 1 inches

Applications

- In-Building Riser Runs
- Short Antenna Installs
- RF Test Systems
- General Purpose RF Interconnect
- Laboratory Applications

Description

LMR-400-FR Fire Rated version of the 400 series Low Loss Coax from Times Microwave is part of the large product offering by Pasternack of radio frequency coaxial cable types specifically stocked to be ready for same-day shipment. Pasternack LMR-400-FR coax cable is manufactured in a flexible design and has a 50 Ohm impedance. This low loss and CMR riser rated 50 Ohm coax cable LMR-400-FR is constructed with a 0.405 inch diameter and Black FRPE jacket.

LMR-400-FR flexible 50 Ohm coax cable with FRPE jacket is rated for a 5.8 GHz maximum operating frequency. This 50 Ohm 0.405 inch diameter and low loss fire rated coax cable is built with an aluminum double shield count and RF shielding of 90 dB. Times Microwave LMR-400-FR FRPE coax is constructed with Foam PE dielectric and a maximum operating temperature of 85 degrees C. Pasternack's offering of LMR-400-FR coax cable provides specs for this wire on its RF coax cable LMR-400-FR datasheet.

LMR-400-FR cable is part of more than one million RF, microwave parts in stock at Pasternack. This Times Microwave low loss flexible LMR-400-FR coax cable is ready to buy and can be shipped worldwide. Pasternack also maintains a wide selection of other radio frequency coaxial cable types that ship same-day from our warehouse as with the rest of our other RF/microwave components.

* LMR™ is a trademark of Times Microwave Systems.

Electrical Specifications

Description	Minimum	Typical	Maximum	Units
Frequency Range	DC		5.8	GHz
Impedance		50		Ohms
Velocity of Propagation		84		%
Time Delay		1.2 3.94		ns/ft ns/m
Shielding Effectiveness	90			dB
Dielectric Withstanding Voltage (DC)			2,500	Vdc

Click the following link (or enter part number in "SEARCH" on website) to obtain additional part information including price, inventory and certifications: [LMR-400-FR Fire Rated version of the 400 series Low Loss Coax LMR-400-FR](#)



LMR-400-FR Fire Rated version of the 400 series Low Loss Coax

RF Cables Technical Data Sheet



LMR-400-FR

Jacket Spark	8,000	Vrms
Inner Conductor DC Resistance	1.39	Ohms/1000ft
Outer Conductor DC Resistance	1.65	Ohms/1000ft
Nominal Capacitance	23.9 [78.41]	pF/ft [pF/m]
Nominal Inductance	0.06 [0.2]	uH/ft [uH/m]
Input Power (Peak)	16	kWatts

Performance by Frequency Band

Description	F1	F2	F3	F4	F5	Units
Frequency	50	150	220	450	900	MHz
Attenuation, Typ	0.9	1.5	1.9	2.7	3.9	dB/100ft
	2.95	4.92	6.23	8.86	12.8	dB/100m
Input Power (CW), Max	2,570	1,470	1,200	830	580	Watts

Description	F6	F7	F8	F9	F10	Units
Frequency	1.5	1.8	2	2.5	5.8	GHz
Attenuation, Typ	5.1	5.7	6	6.8	10.8	dB/100ft
	16.73	18.7	19.69	22.31	35.43	dB/100m
Input Power (CW), Max	440	400	370	330	210	Watts

Mechanical Specifications

Diameter	0.405 in 10.29 mm
Weight	0.068 lbs/ft [0.1 Kg/m]
Min. Bend Radius (Installation)	1 in [25.4 mm]
Min. Bend Radius (Repeated)	4 in [101.6 mm]
Bending Moment	0.5 lbs-ft [0.68 N-m]
Tensile Strength	160 lbs [72.57 kg]
Flat Plate Crush	40 lbs/in [0.71 Kg/mm]

Construction Specifications

Description	Material and Plating	Diameter
Inner Conductor	Copper, 1 Strand	0.108 in [2.74 mm]

Click the following link (or enter part number in "SEARCH" on website) to obtain additional part information including price, inventory and certifications: [LMR-400-FR Fire Rated version of the 400 series Low Loss Coax LMR-400-FR](#)



LMR-400-FR Fire Rated version of the 400 series Low Loss Coax

RF Cables
Technical Data Sheet



LMR-400-FR

Conductor Type	Solid	
Dielectric	Foam PE	0.285 in [7.24 mm]
First Shield	Aluminum Tape	[]
Second Shield	Tinned Copper	[]
Jacket	FRPE, Black	0.405 in [10.29 mm]

Environmental Specifications

Temperature

Operating Range	-40 to +85 deg C
Installation Range	-40 to +85 deg C
Storage Range	-70 to +85 deg C

Compliance Certifications (see [product page](#) for current document)

Plotted and Other Data

Notes:

LMR-400-FR Fire Rated version of the 400 series Low Loss Coax from Pasternack Enterprises has same day shipment for domestic and International orders. Our RF, microwave and millimeter wave products maintain a 99.4% availability and are part of the broadest selection in the industry.

Click the following link (or enter part number in "SEARCH" on website) to obtain additional part information including price, inventory and certifications: [LMR-400-FR Fire Rated version of the 400 series Low Loss Coax LMR-400-FR](#)

URL: <https://www.pasternack.com/low-loss-flexible-lmr-400-fr-frpe-jacket-aluminum-tape-over-tinned-copper-outer-conductor-double-shielded-lmr-400-fr-p.aspx>

The information contained in this document is accurate to the best of our knowledge and representative of the part described herein. It may be necessary to make modifications to the part and/or the documentation of the part, in order to implement improvements. Pasternack reserves the right to make such changes as required. Unless otherwise stated, all specifications are nominal. Pasternack does not make any representation or warranty regarding the suitability of the part described herein for any particular purpose, and Pasternack does not assume any liability arising out of the use of any part or documentation.

REVISIONS		
REV.	DESCRIPTION	DATE
A	INITIAL RELEASE	06-04-2021
		APPROVED
		SELLIS

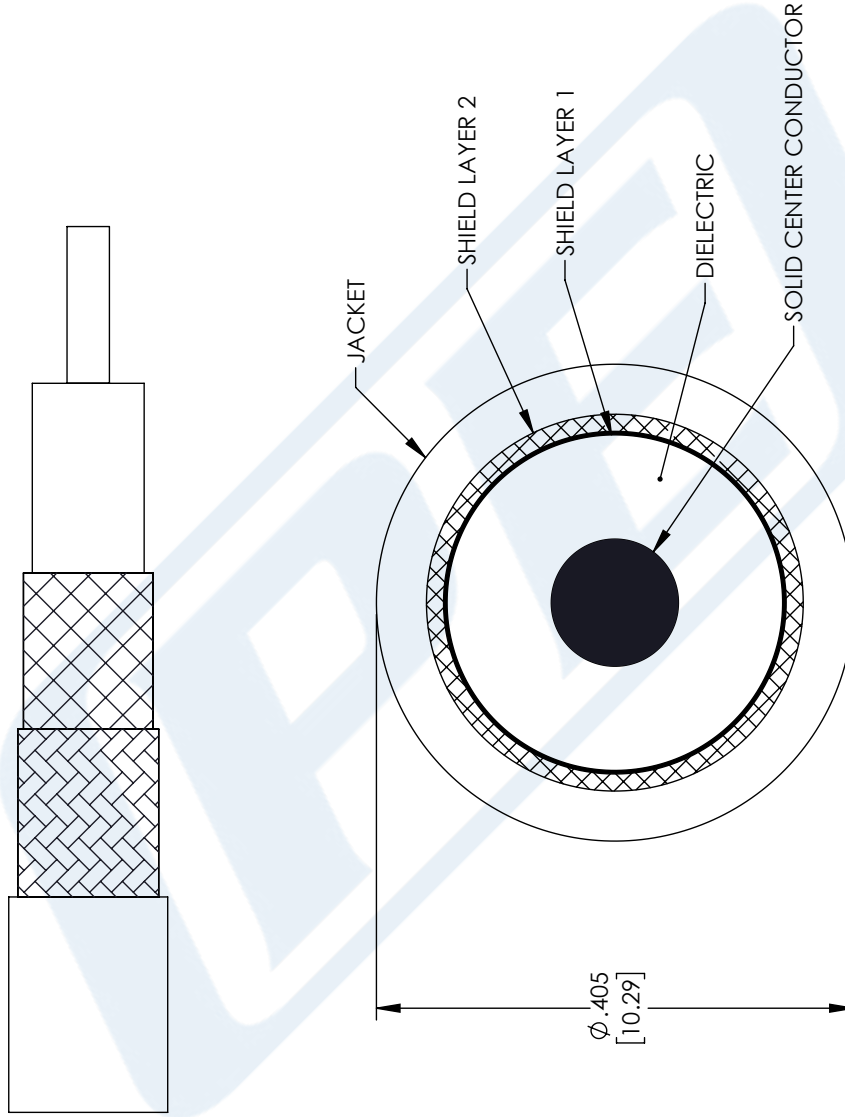

UNLESS OTHERWISE SPECIFIED
 LEADING DIMENSIONS ARE INCHES
 DIMENSIONS IN [] ARE MILLIMETERS

TOLERANCES:
 .X = ±.2 [5.08] FRACTIONS ± 1/32
 .XX = ±.02 [.51] ANGLES ± 1°
 .XXX = ±.005 [.13]

CABLE LENGTH (L) TOLERANCES:
 L ≤ 12 [305] = +1 [25] / -0
 12 [305] < L ≤ 60 [1524] = +2 [51] / -0
 60 [1524] < L ≤ 120 [3048] = +4 [102] / -0
 120 [3048] < L ≤ 300 [7620] = +6 [152] / -0
 300 [7620] < L = +5% / -0

ALL DIMENSIONS SHOWN
 ARE FOR REFERENCE ONLY.

PE PASTERNAK
 an INFINITI brand

Pasternack Enterprises, Inc.
 P. O. Box 16759, Irvine, CA 92623.
 Phone: 1.949.261.1920 | 1.866.727.8376
 Fax: 1.949.261.7451
 Website: www.pasternack.com
 E-mail: sales@pasternack.com

SIZE [CAGE CODE] DRAWN BY ITEM NO.
 A 53919 MVEERAPPAN LMR-400-FR

THIRD-ANGLE PROJECTION

THE INFORMATION AND
 DESIGN IN THIS DOCUMENT
 IS THE PROPERTY OF
 PASTERNAK CORPORATION
 ALL RIGHTS RESERVED.

SHEET 1 OF 1
 SCALE N/A

THESE COMMODITIES, TECHNOLOGY OR SOFTWARE WERE EXPORTED FROM THE UNITED STATES IN ACCORDANCE WITH THE EXPORT ADMINISTRATION REGULATIONS. DIVERSION CONTRARY TO U.S. LAW PROHIBITED.