



TNC Male Connector Crimp/Solder Attachment for LMR-400, PE-C400

RF Connectors Technical Data Sheet



TC-400-TM-X

Times Microwave Systems Connector Specification

Configuration

- TNC Male Connector
- 50 Ohms
- Straight Body Geometry
- Connector Interface Types: LMR-400, PE-C400

Features

- Max. Operating Frequency 6 GHz
- Good VSWR of 1.3:1
- Gold Plated Brass Contact
- 50 µinch contact plating

Applications

- General Purpose Test
- Custom Cable Assemblies

Description

Pasternack's TC-400-TM-X TNC male connector with crimp/solder attachment for LMR-400 and PE-C400 is part of our full line of RF components available for same-day shipping. Our TNC male connector operates up to a maximum frequency of 6 GHz and offers good VSWR of 1.3:1.

Our TNC male connector TC-400-TM-X datasheet specifications and drawing with dimensions are shown below in this PDF. Pasternack's broad catalog of RF, microwave and millimeter wave connectors allows designers to configure and customize their signal connections however they like. Whether the need is to provide an I/O for a board design, or simply create a custom cable assembly configuration, Pasternack has the right connector for the job. Pasternack can also expertly build your custom cable assemblies for you and ship same-day.

Electrical Specifications

Description	Minimum	Typical	Maximum	Units
Frequency Range	DC		6	GHz
VSWR			1.3:1	
Insertion Loss			0.25	dB
Dielectric Withstanding Voltage (AC)			1,000	Vrms
Insulation Resistance	5,000			MOhms

Mechanical Specifications

Size

Length	1.897 in [48.18 mm]
Width/Dia.	0.622 in [15.80 mm]
Weight	0.091 lbs [41.28 g]
Mating Cycles	500 Cycles

Click the following link (or enter part number in "SEARCH" on website) to obtain additional part information including price, inventory and certifications: [TNC Male Connector Crimp/Solder Attachment for LMR-400, PE-C400 TC-400-TM-X](#)



TNC Male Connector Crimp/Solder
Attachment for LMR-400, PE-C400

RF Connectors
Technical Data Sheet

Material Specifications

Description	Material	Plating
Contact	Brass	Gold 50 µinch
Body	Brass	Tri-Metal 80 µinch
Coupling Nut	Brass	Tri-Metal 80 µinch

Environmental Specifications

Temperature

Operating Range

-40 to +125 deg C

Shock

MIL-STD 202G, Meth. 213, Cond. G

Vibration

MIL-STD 202G, Meth. 204, Cond. B

Thermal Shock

MIL-STD 202G, Meth. 107, Cond. B

Compliance Certifications (see [product page](#) for current document)

Plotted and Other Data

Notes:

TNC Male Connector Crimp/Solder Attachment for LMR-400, PE-C400 from Pasternack Enterprises has same day shipment for domestic and International orders. Our RF, microwave and millimeter wave products maintain a 99.4% availability and are part of the broadest selection in the industry.

Click the following link (or enter part number in "SEARCH" on website) to obtain additional part information including price, inventory and certifications: [TNC Male Connector Crimp/Solder Attachment for LMR-400, PE-C400 TC-400-TM-X](#)

URL: <https://www.pasternack.com/tnc-male-lmr-400-pe-c400-connector-tc-400-tm-x-p.aspx>

The information contained in this document is accurate to the best of our knowledge and representative of the part described herein. It may be necessary to make modifications to the part and/or the documentation of the part, in order to implement improvements. Pasternack reserves the right to make such changes as required. Unless otherwise stated, all specifications are nominal. Pasternack does not make any representation or warranty regarding the suitability of the part described herein for any particular purpose, and Pasternack does not assume any liability arising out of the use of any part or documentation.

REVISIONS			
REV.	DESCRIPTION	DATE	APPROVED
A	PCR TC-400-TM-X 20200629	07/03/20	SRAUTUS

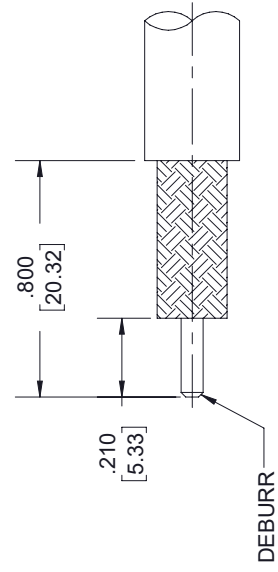
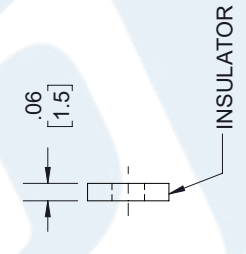
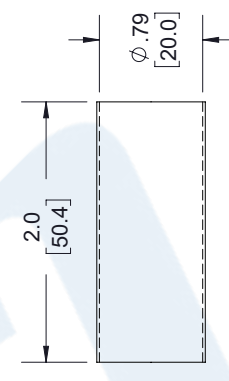
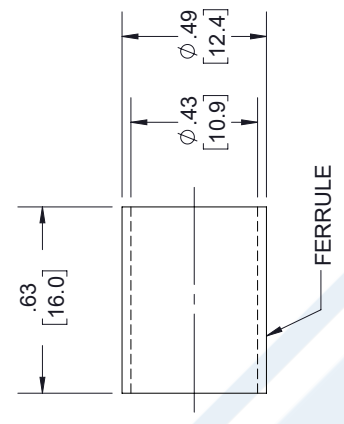
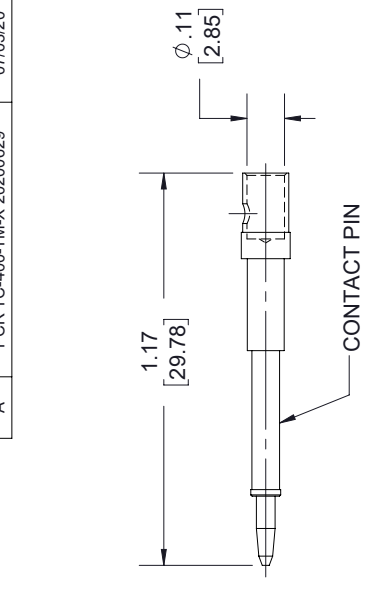

RECOMMENDED CABLE STRIPPING DIMENSIONS

CABLE ATTACHMENT:
INNER: SOLDER.
OUTER: CRIMP.

UNLESS OTHERWISE SPECIFIED LEADING DIMENSIONS ARE INCHES DIMENSIONS IN [] ARE MILLIMETERS

TOLERANCES:
 .X = ±.2 [5.08] FRACTIONS ± 1/32
 .XX = ±.02 [.51] ANGLES ± 1°
 .XXX = ±.005 [.13]
 CABLE LENGTH (L) TOLERANCES:
 L ≤ 12 [305] = +1 [25] / -0
 12 [305] < L ≤ 60 [1524] = +2 [51] / -0
 60 [1524] < L ≤ 120 [3048] = +4 [102] / -0
 120 [3048] < L ≤ 300 [7620] = +6 [152] / -0
 300 [7620] < L = +5% / -0

ALL DIMENSIONS SHOWN ARE FOR REFERENCE ONLY.

THIRD-ANGLE PROJECTION



THE INFORMATION AND DESIGN ARE THE PROPERTY OF PASTERNAK CORPORATION ALL RIGHTS RESERVED.

PE PASTERNAK
an INFINITE brand

Pasternack Enterprises, Inc.
 P.O. Box 16759, Irvine, CA 92623.
 Phone: 1.949.261.1920 | 1.866.727.8376
 Fax: 1.949.261.7451
 Website: www.pasternack.com
 E-mail: sales@pasternack.com

SHEET 1 OF 1
SCALE N/A

ITEM NO. TC-400-TM-X
CAGE CODE 53919
DRAWN BY SLI
REV A



TNC Male Connector Crimp/Solder Attachment for LMR-400, PE-C400

RF Connectors Technical Data Sheet



TC-400-TM-X

Times Microwave Systems Connector Specification

Configuration

- TNC Male Connector
- 50 Ohms
- Straight Body Geometry
- Connector Interface Types: LMR-400, PE-C400

Features

- Max. Operating Frequency 6 GHz
- Good VSWR of 1.3:1
- Gold Plated Brass Contact
- 50 µinch contact plating

Applications

- General Purpose Test
- Custom Cable Assemblies

Description

Pasternack's TC-400-TM-X TNC male connector with crimp/solder attachment for LMR-400 and PE-C400 is part of our full line of RF components available for same-day shipping. Our TNC male connector operates up to a maximum frequency of 6 GHz and offers good VSWR of 1.3:1.

Our TNC male connector TC-400-TM-X datasheet specifications and drawing with dimensions are shown below in this PDF. Pasternack's broad catalog of RF, microwave and millimeter wave connectors allows designers to configure and customize their signal connections however they like. Whether the need is to provide an I/O for a board design, or simply create a custom cable assembly configuration, Pasternack has the right connector for the job. Pasternack can also expertly build your custom cable assemblies for you and ship same-day.

Electrical Specifications

Description	Minimum	Typical	Maximum	Units
Frequency Range	DC		6	GHz
VSWR			1.3:1	
Insertion Loss			0.25	dB
Dielectric Withstanding Voltage (AC)			1,000	Vrms
Insulation Resistance	5,000			MOhms

Mechanical Specifications

Size

Length	1.897 in [48.18 mm]
Width/Dia.	0.622 in [15.80 mm]
Weight	0.091 lbs [41.28 g]
Mating Cycles	500 Cycles

Click the following link (or enter part number in "SEARCH" on website) to obtain additional part information including price, inventory and certifications: [TNC Male Connector Crimp/Solder Attachment for LMR-400, PE-C400 TC-400-TM-X](#)



TNC Male Connector Crimp/Solder Attachment for LMR-400, PE-C400

RF Connectors
Technical Data Sheet

Material Specifications

Description	Material	Plating
Contact	Brass	Gold 50 µinch
Body	Brass	Tri-Metal 80 µinch
Coupling Nut	Brass	Tri-Metal 80 µinch

Environmental Specifications

Temperature

Operating Range

-40 to +125 deg C

Shock

MIL-STD 202G, Meth. 213, Cond. G

Vibration

MIL-STD 202G, Meth. 204, Cond. B

Thermal Shock

MIL-STD 202G, Meth. 107, Cond. B

Compliance Certifications (see [product page](#) for current document)

Plotted and Other Data

Notes:

TNC Male Connector Crimp/Solder Attachment for LMR-400, PE-C400 from Pasternack Enterprises has same day shipment for domestic and International orders. Our RF, microwave and millimeter wave products maintain a 99.4% availability and are part of the broadest selection in the industry.

Click the following link (or enter part number in "SEARCH" on website) to obtain additional part information including price, inventory and certifications: [TNC Male Connector Crimp/Solder Attachment for LMR-400, PE-C400 TC-400-TM-X](#)

URL: <https://www.pasternack.com/tnc-male-lmr-400-pe-c400-connector-tc-400-tm-x-p.aspx>

The information contained in this document is accurate to the best of our knowledge and representative of the part described herein. It may be necessary to make modifications to the part and/or the documentation of the part, in order to implement improvements. Pasternack reserves the right to make such changes as required. Unless otherwise stated, all specifications are nominal. Pasternack does not make any representation or warranty regarding the suitability of the part described herein for any particular purpose, and Pasternack does not assume any liability arising out of the use of any part or documentation.

REVISIONS			
REV.	DESCRIPTION	DATE	APPROVED
A	PCR TC-400-TM-X 20200629	07/03/20	SRAUTUS

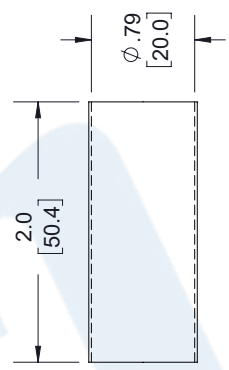
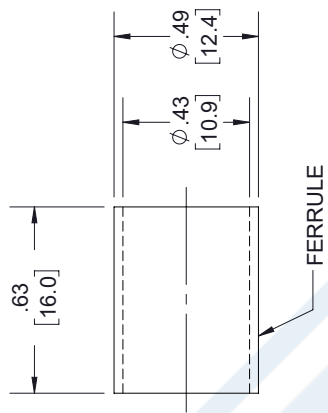
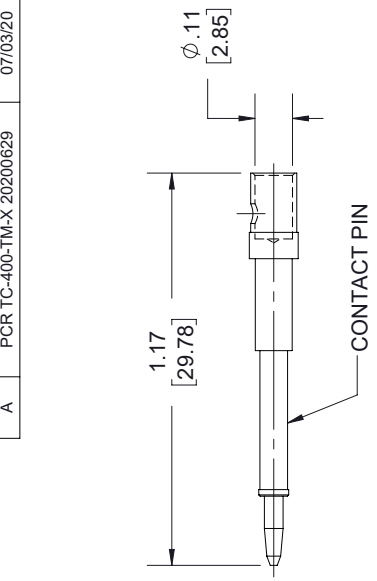

SHRINK TUBE(0.8"x2" 3:1)

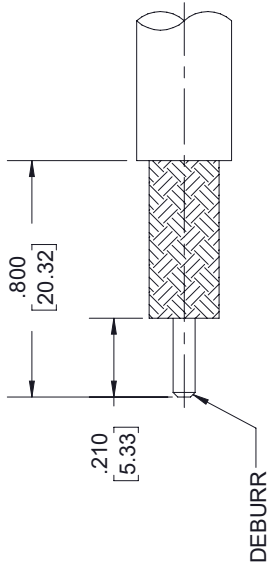
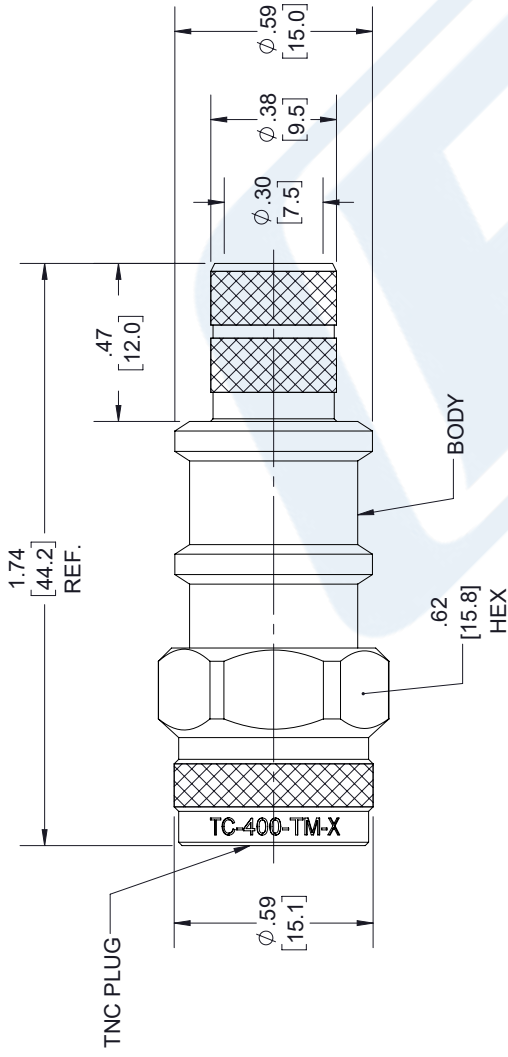
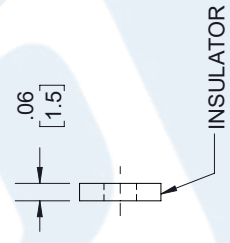

RECOMMENDED CABLE STRIPPING DIMENSIONS

CABLE ATTACHMENT:
INNER: SOLDER.
OUTER: CRIMP.

UNLESS OTHERWISE SPECIFIED LEADING DIMENSIONS ARE INCHES DIMENSIONS IN [] ARE MILLIMETERS

TOLERANCES:
 .X = ±.2 [5.08] FRACTIONS ± 1/32
 .XX = ±.02 [.51] ANGLES ± 1°
 .XXX = ±.005 [.13]
 CABLE LENGTH (L) TOLERANCES:
 L ≤ 12 [305] = +1 [25] / -0
 12 [305] < L ≤ 60 [1524] = +2 [51] / -0
 60 [1524] < L ≤ 120 [3048] = +4 [102] / -0
 120 [3048] < L ≤ 300 [7620] = +6 [152] / -0
 300 [7620] < L = +5% / -0

ALL DIMENSIONS SHOWN ARE FOR REFERENCE ONLY.

PE PASTERNAK
an INFINITE brand

Pasternack Enterprises, Inc.
 P.O. Box 16759, Irvine, CA 92623.
 Phone: 1.949.261.1920 | 1.866.727.8376
 Fax: 1.949.261.7451
 Website: www.pasternack.com
 E-mail: sales@pasternack.com

THIRD-ANGLE PROJECTION

THE INFORMATION AND DESIGN ARE PROPERTY OF PASTERNAK CORPORATION ALL RIGHTS RESERVED.

SHEET 1 OF 1
SCALE N/A

ITEM NO. TC-400-TM-X
CAGE CODE 53919
DRAWN BY SLI
REV A



LMR-LW400 Light weight version of the 400 series Low Loss Coax

Times Microwave Systems Coax Cable Specification

Configuration

- Low Loss, Outdoor Flexible Cable
- 2 Shield(s)

Features

- Light Weight Coax with Aluminum Shielding
- Max Operating Frequency of 8 GHz
- Phase Velocity 84% VoP
- Max Operating Temperature +85°C
- PE Jacket
- Min Install Bend Radius of 1 inches

Applications

- Antenna Installs
- RF Test Systems
- General Purpose RF Interconnect
- Laboratory Applications

Description

LMR-LW400 Light weight version of the 400 series Low Loss Coax from Times Microwave is part of the large product offering by Pasternack of radio frequency coaxial cable types specifically stocked to be ready for same-day shipment. Pasternack LMR-LW400 coax cable is manufactured in a flexible design and has a 50 Ohm impedance. This low loss and light weight flexible 50 Ohm coax cable LMR-LW400 is constructed with a 0.405 inch diameter and Black PE jacket.

LMR-LW400 flexible 50 Ohm coax cable with PE jacket is rated for a 8 GHz maximum operating frequency. This 50 Ohm 0.405 inch diameter and low loss flexible coax cable is built with an aluminum double shield count and RF shielding of 90 dB. Times Microwave LMR-LW400 PE coax is constructed with Foam PE dielectric and a maximum operating temperature of 85 degrees C. Pasternack's offering of LMR-LW400 coax cable provides specs for this wire on its RF coax cable LMR-LW400 datasheet.

LMR-LW400 cable is part of more than one million RF, microwave parts in stock at Pasternack. This Times Microwave low loss and light weight LMR-LW400 coax cable is ready to buy and can be shipped worldwide. Pasternack also maintains a wide selection of other radio frequency coaxial cable types that ship same-day from our warehouse as with the rest of our other RF/microwave components.

* LMR™ is a trademark of Times Microwave Systems.

Electrical Specifications

Description	Minimum	Typical	Maximum	Units
Frequency Range	DC		8	GHz
Impedance		50		Ohms
Velocity of Propagation		84		%
Time Delay		1.2 [3.94]		ns/ft [ns/m]
Shielding Effectiveness	90			dB
Dielectric Withstanding Voltage (DC)			2,500	Vdc
Jacket Spark			8,000	Vrms

Click the following link (or enter part number in "SEARCH" on website) to obtain additional part information including price, inventory and certifications: [LMR-LW400 Light weight version of the 400 series Low Loss Coax LMR-LW400](#)



LMR-LW400 Light weight version of the 400 series Low Loss Coax

RF Cables Technical Data Sheet



LMR-LW400

Inner Conductor DC Resistance	1.39	Ohms/1000ft
Outer Conductor DC Resistance	6.1	Ohms/1000ft
Nominal Capacitance	23.9 [78.41]	pF/ft [pF/m]
Nominal Inductance	0.06 [0.2]	uH/ft [uH/m]
Input Power (Peak)	16	kWatts

Performance by Frequency Band

Description	F1	F2	F3	F4	F5	Units
Frequency	0.05	0.15	0.45	0.9	1.5	GHz
Attenuation, Typ	0.9	1.5	2.7	3.9	5.1	dB/100ft
	2.95	4.92	8.86	12.8	16.73	dB/100m
Input Power (CW), Max	2,570	1,470	830	580	440	Watts

Description	F6	F7	F8	F9	F10	Units
Frequency	1.8	2	2.5	5.8	8	GHz
Attenuation, Typ	5.7	6	6.8	10.8	13	dB/100ft
	18.7	19.69	22.31	35.43	42.65	dB/100m
Input Power (CW), Max	400	370	330	210	170	Watts

Mechanical Specifications

Diameter	0.405 in [10.29 mm]
Weight	0.05 lbs/ft [0.07 kg/m]
Min. Bend Radius (Installation)	1 in [25.4 mm]
Min. Bend Radius (Repeated)	4 in [101.6 mm]
Bending Moment	0.5 lbs-ft [0.68 N-m]
Tensile Strength	160 lbs [72.57 kg]
Flat Plate Crush	40 lbs/in [0.71 kg/mm]

Construction Specifications

Description	Material and Plating	Diameter
Inner Conductor	Copper, 1 Strand	0.108 in [2.74 mm]
Conductor Type	Solid	

Click the following link (or enter part number in "SEARCH" on website) to obtain additional part information including price, inventory and certifications: [LMR-LW400 Light weight version of the 400 series Low Loss Coax LMR-LW400](#)



LMR-LW400 Light weight version of the 400 series Low Loss Coax

RF Cables Technical Data Sheet



LMR-LW400

Dielectric	Foam PE	0.285 in [7.24 mm]
First Shield	Aluminum Tape	[]
Second Shield	Aluminium	[]
Jacket	PE, Black	0.405 in [10.29 mm]

Environmental Specifications

Temperature

Operating Range	-40 to +85 deg C
Installation Range	-40 to +85 deg C
Storage Range	-70 to +85 deg C

Compliance Certifications (see [product page](#) for current document)

Plotted and Other Data

Notes:

LMR-LW400 Light weight version of the 400 series Low Loss Coax from Pasternack Enterprises has same day shipment for domestic and International orders. Our RF, microwave and millimeter wave products maintain a 99.4% availability and are part of the broadest selection in the industry.

Click the following link (or enter part number in "SEARCH" on website) to obtain additional part information including price, inventory and certifications: [LMR-LW400 Light weight version of the 400 series Low Loss Coax LMR-LW400](#)

URL: <https://www.pasternack.com/low-loss-flexible-lmr-lw400-pe-jacket-aluminum-tape-over-aluminium-outer-conductor-double-shielded-lmr-lw400-p.aspx>

The information contained in this document is accurate to the best of our knowledge and representative of the part described herein. It may be necessary to make modifications to the part and/or the documentation of the part, in order to implement improvements. Pasternack reserves the right to make such changes as required. Unless otherwise stated, all specifications are nominal. Pasternack does not make any representation or warranty regarding the suitability of the part described herein for any particular purpose, and Pasternack does not assume any liability arising out of the use of any part or documentation.

REVISIONS		
REV.	DESCRIPTION	DATE
A	INITIAL RELEASE	06-04-2021
		APPROVED
		SELLIS

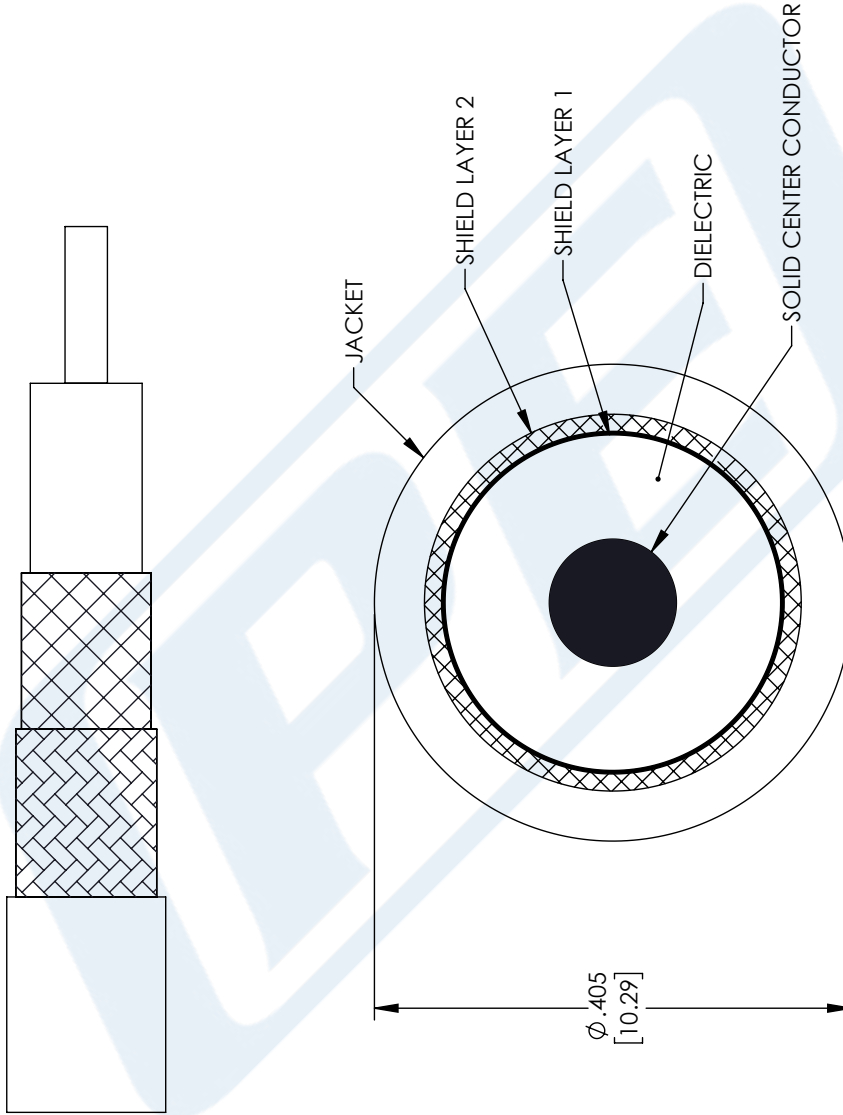

UNLESS OTHERWISE SPECIFIED LEADING DIMENSIONS ARE INCHES DIMENSIONS IN [] ARE MILLIMETERS TOLERANCES: .X = ±.2 [.508] FRACTIONS ± 1/32 .XX = ±.02 [.51] ± 1/32 .XXX = ±.005 [.13] ANGLES ± 1° CABLE LENGTH (L): TOLERANCES: L ≤ 12 [305] = +1 [25] / -0 12 [305] < L ≤ 60 [1524] = +2 [51] / -0 60 [1524] < L ≤ 120 [3048] = +4 [102] / -0 120 [3048] < L ≤ 300 [7620] = +6 [152] / -0 300 [7620] < L = +5% / -0 ALL DIMENSIONS SHOWN ARE FOR REFERENCE ONLY.	PE PASTERNAK an INFINITI brand Pasternack Enterprises, Inc. P. O. Box 16759, Irvine, CA 92623. Phone: 1.949.261.1920 1.866.727.8376 Fax: 1.949.261.7451 Website: www.pasternack.com E-mail: sales@pasternack.com	THIRD-ANGLE PROJECTION THE INFORMATION AND DESIGN IN THIS DOCUMENT IS THE PROPERTY OF PASTERNAK CORPORATION ALL RIGHTS RESERVED. SHEET 1 OF 1 SCALE N/A
	SIZE A CAGE CODE 53919 DRAWN BY MVEERAPPAN ITEM NO. LMR-LW400	REV A

THESE COMMODITIES, TECHNOLOGY OR SOFTWARE WERE EXPORTED FROM THE UNITED STATES IN ACCORDANCE WITH THE EXPORT ADMINISTRATION REGULATIONS. DIVERSION CONTRARY TO U.S. LAW PROHIBITED.