



# BNC Female Connector Clamp/Solder Attachment 4 Hole Flange Mount for RG58, RG142, RG223, RG400, RG141, .500 inch Threaded Hole Spacing

## RF Connectors Technical Data Sheet

PE4056

### Configuration

- BNC Female Connector
- 50 Ohms
- Straight Body Geometry
- Connector Interface Types: RG58, RG142, RG223, RG400, RG141, RG303, RG55, LMR-195, PE-C195, PE-P195
- 4 Hole Flange

### Features

- Gold Plated Brass Contact

### Applications

- General Purpose Test
- Rack and Panel Mount Applications
- Custom Cable Assemblies

### Description

Pasternack's PE4056 BNC female 4 hole flange mount connector with clamp/solder attachment for RG58, RG142, RG223, RG400, RG141, RG303, RG55, LMR-195, PE-C195 and PE-P195 (.500 inch threaded hole spacing) is part of our full line of RF components available for same-day shipping. This BNC 4 hole flange connector allows designers to create external connections on their product enclosures, and can be used in a variety of other rack mount and panel mount applications.

Our BNC female 4 hole flange connector PE4056 datasheet specifications and drawing with dimensions are shown below in this PDF. Pasternack's broad catalog of RF, microwave and millimeter wave connectors allows designers to configure and customize their signal connections however they like. Whether the need is to provide an I/O for a board design, or simply create a custom cable assembly configuration, Pasternack has the right connector for the job. Pasternack can also expertly build your custom cable assemblies for you and ship same-day.

### Mechanical Specifications

#### Size

Length	1.15 in [29.21 mm]
Width/Dia.	0.687 in [17.45 mm]
Height	0.687 in [17.45 mm]
Weight	0.039 lbs [17.69 g]

#### Material Specifications

Description	Material	Plating
Contact	Brass	Gold
Insulation	PTFE	
Body	Brass	Nickel

Click the following link (or enter part number in "SEARCH" on website) to obtain additional part information including price, inventory and certifications: [BNC Female Connector Clamp/Solder Attachment 4 Hole Flange Mount for RG58, RG142, RG223, RG400, RG141, .500 inch Threaded Hole Spacing PE4056](#)



BNC Female Connector Clamp/Solder Attachment  
4 Hole Flange Mount for RG58, RG142, RG223,  
RG400, RG141, .500 inch Threaded Hole Spacing

RF Connectors  
Technical Data Sheet

PE4056

**Environmental Specifications**

**Compliance Certifications** (see [product page](#) for current document)

**Plotted and Other Data**

Notes:

BNC Female Connector Clamp/Solder Attachment 4 Hole Flange Mount for RG58, RG142, RG223, RG400, RG141, .500 inch Threaded Hole Spacing from Pasternack Enterprises has same day shipment for domestic and International orders. Our RF, microwave and millimeter wave products maintain a 99.4% availability and are part of the broadest selection in the industry.

Click the following link (or enter part number in "SEARCH" on website) to obtain additional part information including price, inventory and certifications: [BNC Female Connector Clamp/Solder Attachment 4 Hole Flange Mount for RG58, RG142, RG223, RG400, RG141, .500 inch Threaded Hole Spacing PE4056](#)

URL: <https://www.pasternack.com/bnc-female-rg58-rg142-rg400-rg141-rg303-rg55-lmr-195-connector-pe4056-p.aspx>

The information contained in this document is accurate to the best of our knowledge and representative of the part described herein. It may be necessary to make modifications to the part and/or the documentation of the part, in order to implement improvements. Pasternack reserves the right to make such changes as required. Unless otherwise stated, all specifications are nominal. Pasternack does not make any representation or warranty regarding the suitability of the part described herein for any particular purpose, and Pasternack does not assume any liability arising out of the use of any part or documentation.

# PE4056 CAD Drawing

BNC Female Connector Clamp/Solder Attachment 4 Hole Flange Mount for  
RG58, RG142, RG223, RG400, RG141, .500 inch Threaded Hole Spacing

REVISIONS		
REV.	DESCRIPTION	DATE
B	REMOVE WASHER	02/03/2022
		APPROVED
		MDING

## ASSEMBLY PROCEDURES

- SLIDE CLAMP NUT (1), & GASKET (2) OVER CABLE. STRIP CABLE AS SHOWN. DO NOT NICK BRAID WHILE CUTTING JACKET. TAPER END OF BRAID TO PERMIT ASSEMBLY OF BRAID CLAMP (3). SLIDE BRAID CLAMP (3) OVER BRAID & SEAT AGAINST CABLE.
- FORM BRAID OVER CLAMP NUT (3). TRIM BRAID BACK TO SHOULDER. CUT DIELECTRIC & CENTER CONDUCTOR TO DIMENSION SHOWN. DO NOT NICK CENTER CONDUCTOR. REMOVE EXCESS SOLDER. DO NOT OVER HEAT DIELECTRIC. INSERT CABLE ASSEMBLY INTO BODY & TIGHTEN.

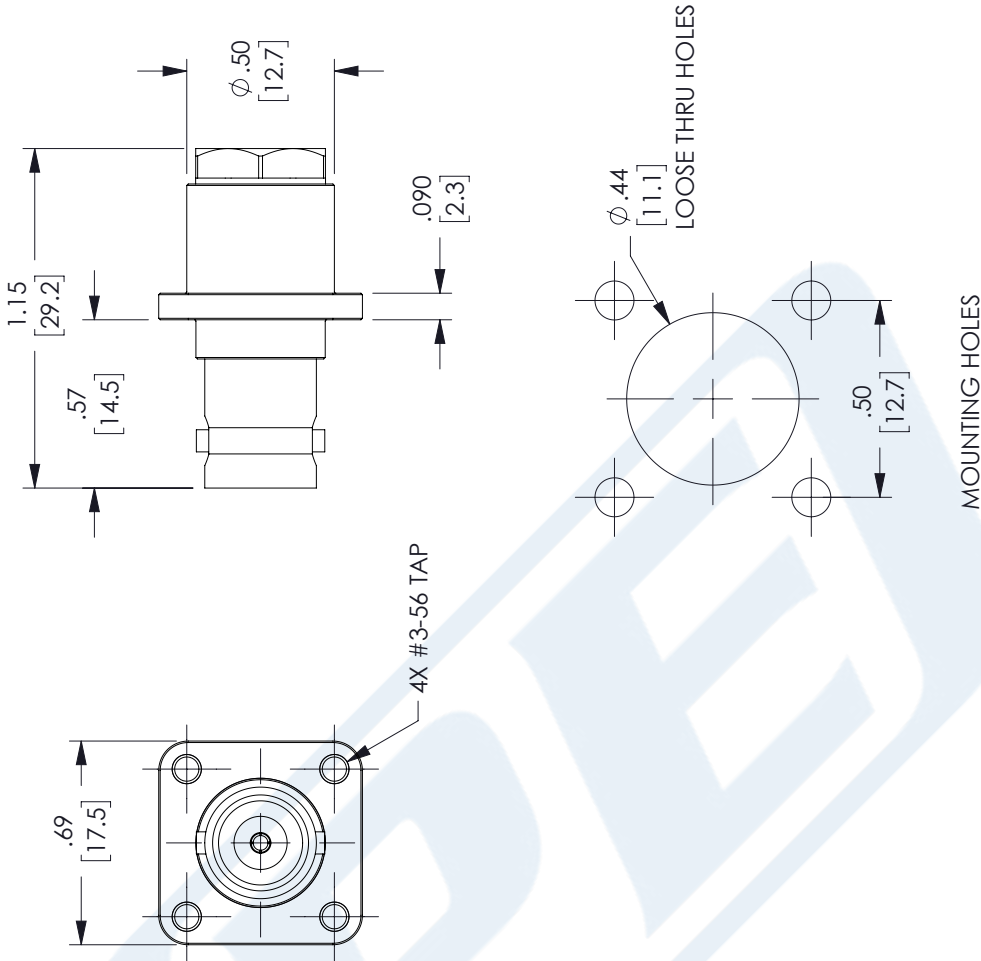

MOUNTING HOLES

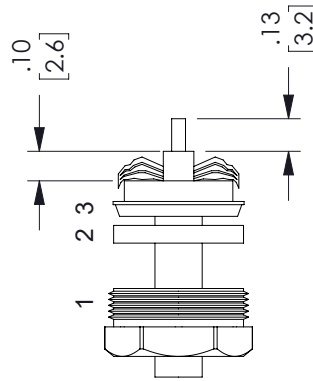

UNLESS OTHERWISE SPECIFIED  
LEADING DIMENSIONS ARE INCHES  
DIMENSIONS IN [ ] ARE MILLIMETERS

TOLERANCES:  
 .X = ±.2 [5.08]    FRACTIONS ± 1/32  
 .XX = ±.02 [.51]    ANGLES ± 1°  
 .XXX = ±.005 [.13]  
 CABLE LENGTH (L) TOLERANCES:  
 L ≤ 12 [305] = +1 [25] / -0  
 12 [305] < L ≤ 60 [1524] = +2 [51] / -0  
 60 [1524] < L ≤ 120 [3048] = +4 [102] / -0  
 120 [3048] < L ≤ 300 [7620] = +6 [152] / -0  
 300 [7620] < L = +5%L / -0  
 ALL DIMENSIONS SHOWN  
 ARE FOR REFERENCE ONLY.



THE INFORMATION AND  
DESIGN IN THIS DOCUMENT  
IS THE PROPERTY OF  
PASTERNAK CORPORATION  
ALL RIGHTS RESERVED.

SHEET 1 OF 1  
SCALE N/A



Pasternack Enterprises, Inc.  
P. O. Box 16759, Irvine, CA 92623.  
Phone: 1.949.261.1920 | 1.866.727.8376  
Fax: 1.949.261.7451  
Website: www.pasternack.com  
E-mail: sales@pasternack.com

ITEM NO. PE4056  
DRAWN BY DMAY  
CAGE CODE A 53919

REV B



**BNC Female Connector Clamp/Solder Attachment  
4 Hole Flange Mount for RG58, RG142, RG223,  
RG400, RG141, .500 inch Threaded Hole Spacing**

**RF Connectors  
Technical Data Sheet**

**PE4056**

**Configuration**

- BNC Female Connector
- 50 Ohms
- Straight Body Geometry
- Connector Interface Types: RG58, RG142, RG223, RG400, RG141, RG303, RG55, LMR-195, PE-C195, PE-P195
- 4 Hole Flange

**Features**

- Gold Plated Brass Contact

**Applications**

- General Purpose Test
- Rack and Panel Mount Applications
- Custom Cable Assemblies

**Description**

Pasternack's PE4056 BNC female 4 hole flange mount connector with clamp/solder attachment for RG58, RG142, RG223, RG400, RG141, RG303, RG55, LMR-195, PE-C195 and PE-P195 (.500 inch threaded hole spacing) is part of our full line of RF components available for same-day shipping. This BNC 4 hole flange connector allows designers to create external connections on their product enclosures, and can be used in a variety of other rack mount and panel mount applications.

Our BNC female 4 hole flange connector PE4056 datasheet specifications and drawing with dimensions are shown below in this PDF. Pasternack's broad catalog of RF, microwave and millimeter wave connectors allows designers to configure and customize their signal connections however they like. Whether the need is to provide an I/O for a board design, or simply create a custom cable assembly configuration, Pasternack has the right connector for the job. Pasternack can also expertly build your custom cable assemblies for you and ship same-day.

**Mechanical Specifications**

**Size**

Length	1.15 in [29.21 mm]
Width/Dia.	0.687 in [17.45 mm]
Height	0.687 in [17.45 mm]
Weight	0.039 lbs [17.69 g]

**Material Specifications**

Description	Material	Plating
Contact	Brass	Gold
Insulation	PTFE	
Body	Brass	Nickel

Click the following link (or enter part number in "SEARCH" on website) to obtain additional part information including price, inventory and certifications: [BNC Female Connector Clamp/Solder Attachment 4 Hole Flange Mount for RG58, RG142, RG223, RG400, RG141, .500 inch Threaded Hole Spacing PE4056](#)



BNC Female Connector Clamp/Solder Attachment  
4 Hole Flange Mount for RG58, RG142, RG223,  
RG400, RG141, .500 inch Threaded Hole Spacing

RF Connectors  
Technical Data Sheet

PE4056

**Environmental Specifications**

**Compliance Certifications** (see [product page](#) for current document)

**Plotted and Other Data**

Notes:

BNC Female Connector Clamp/Solder Attachment 4 Hole Flange Mount for RG58, RG142, RG223, RG400, RG141, .500 inch Threaded Hole Spacing from Pasternack Enterprises has same day shipment for domestic and International orders. Our RF, microwave and millimeter wave products maintain a 99.4% availability and are part of the broadest selection in the industry.

Click the following link (or enter part number in "SEARCH" on website) to obtain additional part information including price, inventory and certifications: [BNC Female Connector Clamp/Solder Attachment 4 Hole Flange Mount for RG58, RG142, RG223, RG400, RG141, .500 inch Threaded Hole Spacing PE4056](#)

URL: <https://www.pasternack.com/bnc-female-rg58-rg142-rg400-rg141-rg303-rg55-lmr-195-connector-pe4056-p.aspx>

The information contained in this document is accurate to the best of our knowledge and representative of the part described herein. It may be necessary to make modifications to the part and/or the documentation of the part, in order to implement improvements. Pasternack reserves the right to make such changes as required. Unless otherwise stated, all specifications are nominal. Pasternack does not make any representation or warranty regarding the suitability of the part described herein for any particular purpose, and Pasternack does not assume any liability arising out of the use of any part or documentation.

# PE4056 CAD Drawing

BNC Female Connector Clamp/Solder Attachment 4 Hole Flange Mount for  
RG58, RG142, RG223, RG400, RG141, .500 inch Threaded Hole Spacing

REVISIONS		
REV.	DESCRIPTION	DATE
B	REMOVE WASHER	02/03/2022
		APPROVED
		MDING

## ASSEMBLY PROCEDURES

- SLIDE CLAMP NUT (1), & GASKET (2) OVER CABLE. STRIP CABLE AS SHOWN. DO NOT NICK BRAID WHILE CUTTING JACKET. TAPER END OF BRAID TO PERMIT ASSEMBLY OF BRAID CLAMP (3). SLIDE BRAID CLAMP (3) OVER BRAID & SEAT AGAINST CABLE.
- FORM BRAID OVER CLAMP NUT (3). TRIM BRAID BACK TO SHOULDER. CUT DIELECTRIC & CENTER CONDUCTOR TO DIMENSION SHOWN. DO NOT NICK CENTER CONDUCTOR. REMOVE EXCESS SOLDER. DO NOT OVER HEAT DIELECTRIC. INSERT CABLE ASSEMBLY INTO BODY & TIGHTEN.

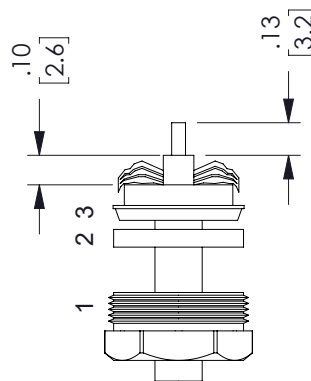
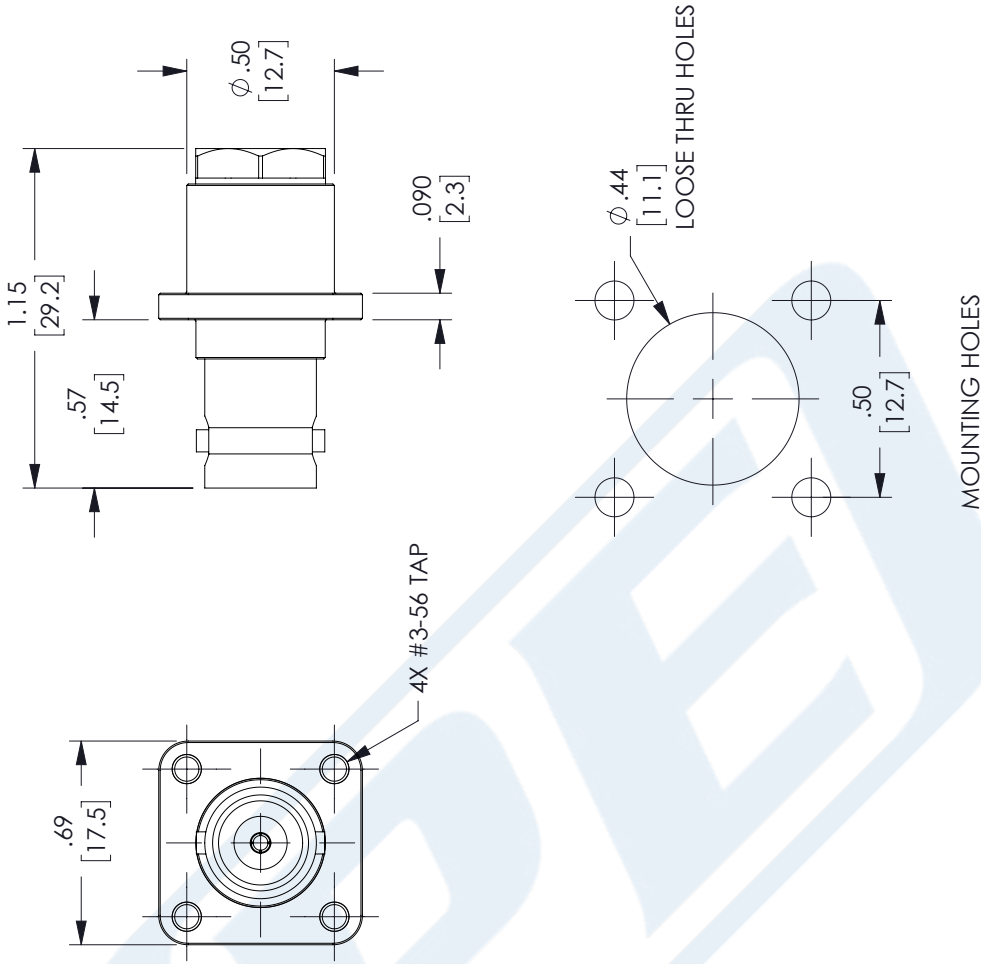

<p>UNLESS OTHERWISE SPECIFIED LEADING DIMENSIONS ARE INCHES DIMENSIONS IN [ ] ARE MILLIMETERS</p> <p>TOLERANCES:</p> <p>.X = ±.2 [5.08]    FRACTIONS ± 1/32          .XX = ±.02 [.51]    ANGLES ± 1°          .XXX = ±.005 [.13]</p> <p>CABLE LENGTH (L) TOLERANCES:          L ≤ 12 [305] = +1 [25] / -0          12 [305] &lt; L ≤ 60 [1524] = +2 [51] / -0          60 [1524] &lt; L ≤ 120 [3048] = +4 [102] / -0          120 [3048] &lt; L ≤ 300 [7620] = +6 [152] / -0          300 [7620] &lt; L = +5%L / -0</p> <p>ALL DIMENSIONS SHOWN ARE FOR REFERENCE ONLY.</p>	<p>THIRD-ANGLE PROJECTION</p> <p>THE INFORMATION AND DESIGN IN THIS DOCUMENT IS THE PROPERTY OF PASTERNAK CORPORATION ALL RIGHTS RESERVED.</p> <p>SHEET 1 OF 1</p> <p>SCALE N/A</p>
	<p>ITEM NO. PE4056</p> <p>REV B</p>
<p>SIZE A</p> <p>CAGE CODE 53919</p> <p>DRAWN BY DMAY</p>	<p>ITEM NO. PE4056</p> <p>REV B</p>

**PE PASTERNAK**  
an INFINITE brand

Pasternack Enterprises, Inc.  
P.O. Box 16759, Irvine, CA 92623.  
Phone: 1.949.261.1920 | 1.866.727.8376  
Fax: 1.949.261.7451  
Website: www.pasternack.com  
E-mail: sales@pasternack.com

THESE COMMODITIES, TECHNOLOGY OR SOFTWARE WERE EXPORTED FROM THE UNITED STATES IN ACCORDANCE WITH THE EXPORT ADMINISTRATION REGULATIONS. DIVERSION CONTRARY TO U.S. LAW PROHIBITED.



## Flexible RG141 Coax Cable Single Shielded with Beige PTFE (Fiberglass reinforced) Jacket

### RF Cables Technical Data Sheet

RG141A/U

#### Configuration

- Flexible Cable
- 1 Shield(s)

#### Electrical Specifications

Description	Minimum	Typical	Maximum	Units
Frequency Range	DC		10	GHz
Impedance		50 ±2		Ohms
Velocity of Propagation		70		%
Dielectric Withstanding Voltage (AC)			5,000	Vrms
Jacket Spark			2,000	Vrms
Nominal Capacitance		29.4 [96.46]		pF/ft [pF/m]

#### Performance by Frequency Band

Description	F1	F2	F3	F4	F5	Units
Frequency	0.01	0.1	1	5	10	GHz
Attenuation, Typ	1.2	3.9	13	36	62	dB/100ft
	3.94	12.8	42.65	118.11	203.41	dB/100m

#### Mechanical Specifications

Diameter	0.19 in [4.83 mm]
Weight	0.033 lbs/ft [0.05 Kg/m]

#### Construction Specifications

Description	Material and Plating	Diameter
Inner Conductor	Copper Clad Steel, Silver, 1 Strands	0.037 in [0.94 mm]
Conductor Type	Solid	
Dielectric	PTFE	0.116 in [2.95 mm]
First Shield	Silver Plated Copper	

Click the following link (or enter part number in "SEARCH" on website) to obtain additional part information including price, inventory and certifications: [Flexible RG141 Coax Cable Single Shielded with Beige PTFE \(FG\) Jacket RG141A/U](#)



## Flexible RG141 Coax Cable Single Shielded with Beige PTFE (Fiberglass reinforced) Jacket

### RF Cables Technical Data Sheet

RG141A/U

Jacket	PTFE (FG), Beige	0.19 in [4.83 mm]
--------	------------------	-------------------

#### Environmental Specifications

##### Temperature

Operating Range -55 to +200 deg C

**Compliance Certifications** (see [product page](#) for current document)

#### Plotted and Other Data

Notes:

Flexible RG141 Coax Cable Single Shielded with Beige PTFE (Fiberglass reinforced) Jacket from Pasternack Enterprises has same day shipment for domestic and International orders. Our RF, microwave and millimeter wave products maintain a 99.4% availability and are part of the broadest selection in the industry.

Click the following link (or enter part number in "SEARCH" on website) to obtain additional part information including price, inventory and certifications: [Flexible RG141 Coax Cable Single Shielded with Beige PTFE \(FG\) Jacket RG141A/U](#)

URL: <https://www.pasternack.com/flexible-0.190-rg141-50-ohm-coax-cable-ptfe-fr-jacket-rg141a-u-p.aspx>

The information contained in this document is accurate to the best of our knowledge and representative of the part described herein. It may be necessary to make modifications to the part and/or the documentation of the part, in order to implement improvements. Pasternack reserves the right to make such changes as required. Unless otherwise stated, all specifications are nominal. Pasternack does not make any representation or warranty regarding the suitability of the part described herein for any particular purpose, and Pasternack does not assume any liability arising out of the use of any part or documentation.

# RG141A/U CAD Drawing

Flexible RG141 Coax Cable Single Shielded with Beige PTFE (Fiberglass reinforced) Jacket

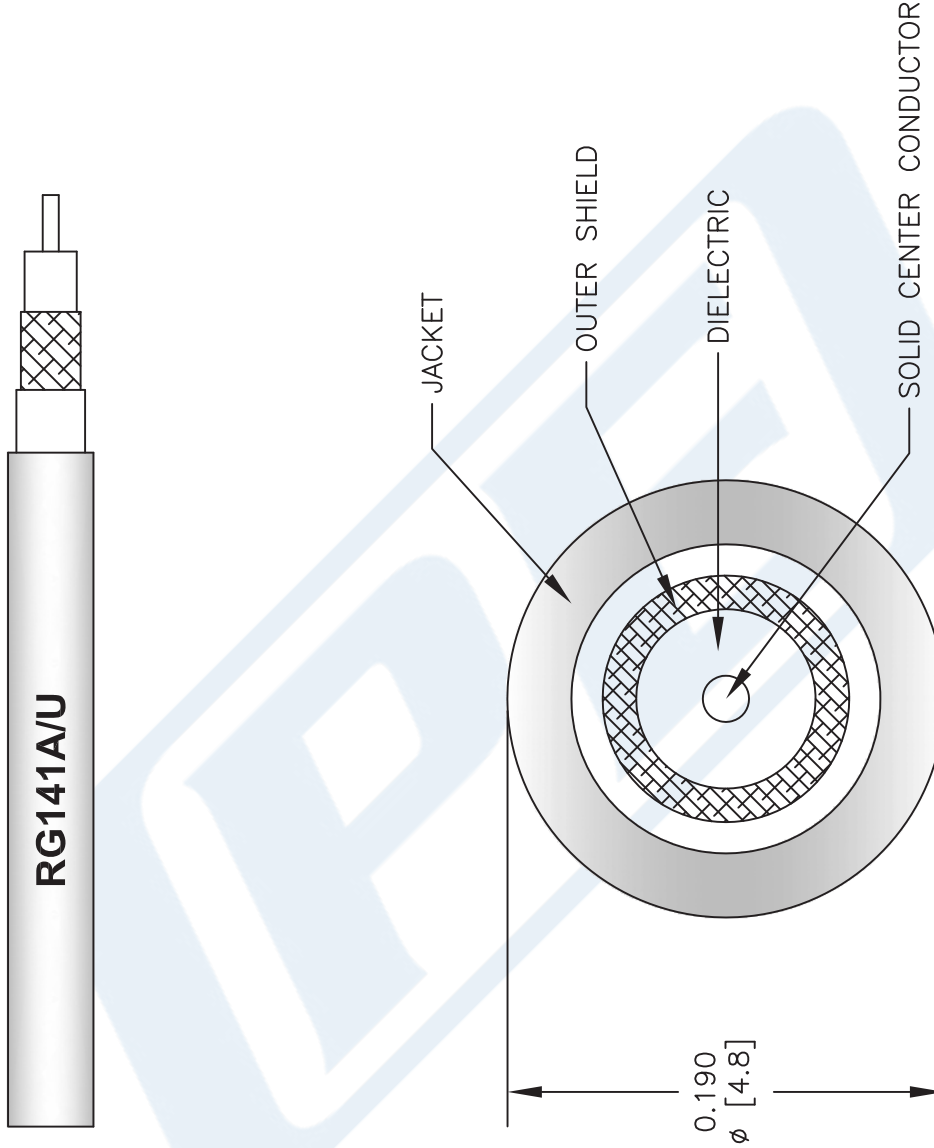

NOTES:  
1. UNLESS OTHERWISE SPECIFIED ALL DIMENSIONS ARE NOMINAL.  
2. ALL SPECIFICATIONS ARE SUBJECT TO CHANGE WITHOUT NOTICE AT ANY TIME.  
3. DIMENSIONS ARE IN INCHES [mm].

DWG TITLE  
**RG141A/U**

REV. A FSCM NO. 53919

SCALE N/A

SIZE A

CAD FILE 022808-A

147

**PE PASTERNAK®**  
Pasternack Enterprises, Inc.  
P.O. Box 16759 | Irvine | CA | 92623  
Phone: (949) 261-1920 | Fax: (949) 261-7451  
Website: www.pasternack.com | E-Mail: sales@pasternack.com