



N Male Connector Crimp/Non-Solder Contact Attachment for LMR-195, PE-C195, LMR-200, PE-C200

RF Connectors Technical Data Sheet



EZ-195-NMH-X

Times Microwave Systems Connector Specification

Configuration

- N Male Connector
- MIL-STD-348
- 50 Ohms
- Straight Body Geometry
- Connector Interface Types: LMR-195, PE-C195, LMR-200, PE-C200

Features

- Max. Operating Frequency 6 GHz
- Good VSWR of 1.3:1
- Gold Plated Beryllium Copper Contact
- 50 μ m Thickness contact plating

Applications

- General Purpose Test
- Custom Cable Assemblies

Description

Pasternack's EZ-195-NMH-X type N, N, Standard, Connector is part of our full line of RF components available for same-day shipping. Our type N male connector operates up to a maximum frequency of 6 GHz and offers good VSWR of 1.3:1.

Our type N male connector EZ-195-NMH-X datasheet specifications and drawing with dimensions are shown below in this PDF. Pasternack's broad catalog of RF, microwave and millimeter wave connectors allows designers to configure and customize their signal connections however they like. Whether the need is to provide an I/O for a board design, or simply create a custom cable assembly configuration, Pasternack has the right connector for the job. Pasternack can also expertly build your custom cable assemblies for you and ship same-day.

Electrical Specifications

Description	Minimum	Typical	Maximum	Units
Frequency Range	DC		6	GHz
VSWR			1.3:1	
Insertion Loss			0.25	dB
Impedance		50		Ohms
Dielectric Withstanding Voltage (DC)			1,000	Vdc
Insulation Resistance	5,000			MOhms

Mechanical Specifications

Size

Length	1.27 in [32.26 mm]
Width	0.81 in [20.62 mm]
Height	0.81 in [20.62 mm]
Weight	0.08 lbs [35.83 g]
Mating Cycles	500 Cycles

Click the following link (or enter part number in "SEARCH" on website) to obtain additional part information including price, inventory and certifications: [N Male Connector Crimp/Non-Solder Contact Attachment for LMR-195, PE-C195, LMR-200, PE-C200 EZ-195-NMH-X](#)



N Male Connector Crimp/Non-Solder Contact Attachment for LMR-195, PE-C195, LMR-200, PE-C200

RF Connectors Technical Data Sheet



EZ-195-NMH-X

Material Specifications

Description	Material	Plating
Contact	Beryllium Copper	Gold 50 µin Thickness
Insulation	PTFE	
Outer Conductor	Brass	Tri-Metal 80 µin Thickness
Body	Brass	Tri-Metal 80 µin Thickness
Coupling Nut	Brass	Tri-Metal 80 µin Thickness

Environmental Specifications

Temperature

Operating Range

-40 to +125 deg C

Shock

MIL-STD 202G, Meth. 213, Cond. I

Vibration

MIL-STD 202G, Meth. 204, Cond.B

Thermal Shock

MIL-STD 202G, Meth. 107, Cond.B

Compliance Certifications (see [product page](#) for current document)

Plotted and Other Data

Notes:

N Male Connector Crimp/Non-Solder Contact Attachment for LMR-195, PE-C195, LMR-200, PE-C200 from Pasternack Enterprises has same day shipment for domestic and International orders. Our RF, microwave and millimeter wave products maintain a 99.4% availability and are part of the broadest selection in the industry.

Click the following link (or enter part number in "SEARCH" on website) to obtain additional part information including price, inventory and certifications: [N Male Connector Crimp/Non-Solder Contact Attachment for LMR-195, PE-C195, LMR-200, PE-C200 EZ-195-NMH-X](#)

URL: <https://www.pasternack.com/n-male-lmr-195-pe-c195-connector-ez-195-nmh-x-p.aspx>

The information contained in this document is accurate to the best of our knowledge and representative of the part described herein. It may be necessary to make modifications to the part and/or the documentation of the part, in order to implement improvements. Pasternack reserves the right to make such changes as required. Unless otherwise stated, all specifications are nominal. Pasternack does not make any representation or warranty regarding the suitability of the part described herein for any particular purpose, and Pasternack does not assume any liability arising out of the use of any part or documentation.

TIMES MICROWAVE SYSTEMS **EZ-195-NMH-X CAD Drawing**
 N Male Connector Crimp/Non-Solder Contact Attachment
 for LMR-195, PE-C195, LMR-200, PE-C200

REVISIONS			
REV.	DESCRIPTION	DATE	APPROVED
A	INITIAL RELEASE	6/16/2022	A. GANWANI

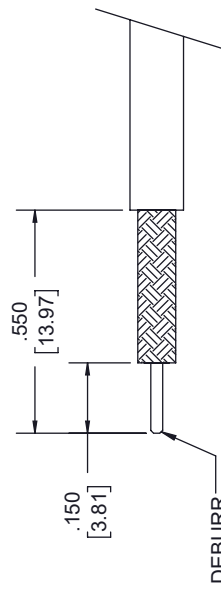
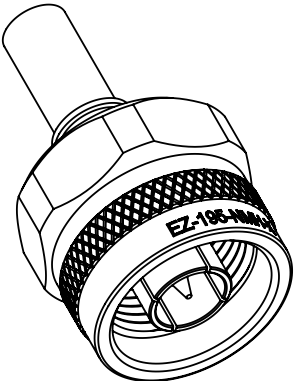
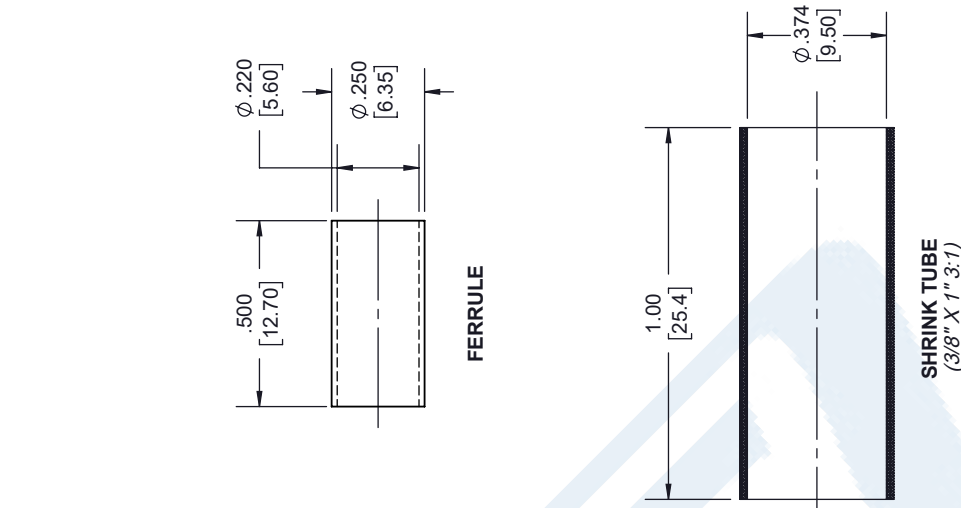

STRIPPING DIMENSIONS

- NOTES:**
- CABLE ATTACHMENT:
 - OUTER: CRIMP.
 - INNER: SOLDER.
 - CRIMP SIZE REQUIRED:
 - FERRULE: .213 [5.41] HEX. CRIMP TOOL.
 - CONTACT: SOLDER.

UNLESS OTHERWISE SPECIFIED LEADING DIMENSIONS ARE INCHES DIMENSIONS IN [] ARE MILLIMETERS

TOLERANCES:

X = ±.2	[5.08]	FRACTIONS	±.132
.XX = ±.02	[.51]	ANGLES	± 1°
.XXX = ±.005	[.13]	CABLE LENGTH (L)	TOLERANCES:
		L ≤ 12 [305]	= +1 [25] / -0
		12 [305] < L ≤ 60 [1524]	= +2 [51] / -0
		60 [1524] < L ≤ 120 [3048]	= +4 [102] / -0
		120 [3048] < L ≤ 300 [7620]	= +6 [152] / -0
		300 [7620] < L = +5% L / -0	

ALL DIMENSIONS SHOWN ARE FOR REFERENCE ONLY.

THIRD-ANGLE PROJECTION

THE INFORMATION AND DESIGN IN THIS DOCUMENT IS THE PROPERTY OF PASTERNAK CORPORATION. ALL RIGHTS RESERVED.

SHEET 1 OF 1

SCALE N/A

PE PASTERNAK
an INFINITO brand

Pasternack Enterprises, Inc.
 P.O. Box 16759, Irvine, CA 92623
 Phone: 1.949.261.1920 | 1.866.727.8376
 Fax: 1.949.261.7451
 Website: www.pasternack.com
 E-mail: sales@pasternack.com

SIZE	CAGE CODE	DRAWN BY	ITEM NO.
A	53919	K.DANG	EZ-195-NMH-X

REV A

THESE COMMODITIES, TECHNOLOGY OR SOFTWARE WERE EXPORTED FROM THE UNITED STATES IN ACCORDANCE WITH THE EXPORT ADMINISTRATION REGULATIONS. DIVERSION CONTRARY TO U.S. LAW PROHIBITED.



SMA Male Right Angle Connector Crimp/Solder Attachment for PE-C200, LMR-200

RF Connectors
Technical Data Sheet

PE45546

Configuration

- SMA Male Connector
- 50 Ohms
- Right Angle Body Geometry
- Connector Interface Types: PE-C200, LMR-200

Features

- Max. Operating Frequency 6 GHz
- Gold Plated Brass Contact

Applications

- General Purpose Test
- Custom Cable Assemblies

Description

Pasternack's PE45546 SMA male right angle connector with crimp/solder attachment for PE-C200 and LMR-200 is part of our full line of RF components available for same-day shipping. Our SMA male connector operates up to a maximum frequency of 6 GHz. Its right angle body geometry allows for easier connections in tight spaces.

Our SMA male right angle connector PE45546 datasheet specifications and drawing with dimensions are shown below in this PDF. Pasternack's broad catalog of RF, microwave and millimeter wave connectors allows designers to configure and customize their signal connections however they like. Whether the need is to provide an I/O for a board design, or simply create a custom cable assembly configuration, Pasternack has the right connector for the job. Pasternack can also expertly build your custom cable assemblies for you and ship same-day.

Electrical Specifications

Description	Minimum	Typical	Maximum	Units
Frequency Range	DC		6	GHz

Mechanical Specifications

Size	
Length	0.713 in [18.11 mm]
Weight	0.023 lbs [10.43 g]

Click the following link (or enter part number in "SEARCH" on website) to obtain additional part information including price, inventory and certifications: [SMA Male Right Angle Connector Crimp/Solder Attachment for PE-C200, LMR-200 PE45546](#)



SMA Male Right Angle Connector Crimp/Solder Attachment for PE-C200, LMR-200

RF Connectors
Technical Data Sheet

PE45546

Material Specifications

Description	Material	Plating
Contact	Brass	Gold
Insulation	PTFE	
Body	Brass	Gold
Coupling Nut	Brass	Gold

Environmental Specifications

Temperature

Operating Range -65 to +165 deg C

Compliance Certifications (see [product page](#) for current document)

Plotted and Other Data

Notes:

SMA Male Right Angle Connector Crimp/Solder Attachment for PE-C200, LMR-200 from Pasternack Enterprises has same day shipment for domestic and International orders. Our RF, microwave and millimeter wave products maintain a 99.4% availability and are part of the broadest selection in the industry.

Click the following link (or enter part number in "SEARCH" on website) to obtain additional part information including price, inventory and certifications: [SMA Male Right Angle Connector Crimp/Solder Attachment for PE-C200, LMR-200 PE45546](#)

URL: <https://www.pasternack.com/sma-male-pe-c200-lmr-200-connector-pe45546-p.aspx>

The information contained in this document is accurate to the best of our knowledge and representative of the part described herein. It may be necessary to make modifications to the part and/or the documentation of the part, in order to implement improvements. Pasternack reserves the right to make such changes as required. Unless otherwise stated, all specifications are nominal. Pasternack does not make any representation or warranty regarding the suitability of the part described herein for any particular purpose, and Pasternack does not assume any liability arising out of the use of any part or documentation.

PE45546 CAD Drawing

SMA Male Right Angle Connector Crimp/Solder Attachment for PE-C200, LMR-200

REVISIONS			
REV.	DESCRIPTION	DATE	APPROVED
A	INITIAL RELEASE	07/25/19	S.ELLIS

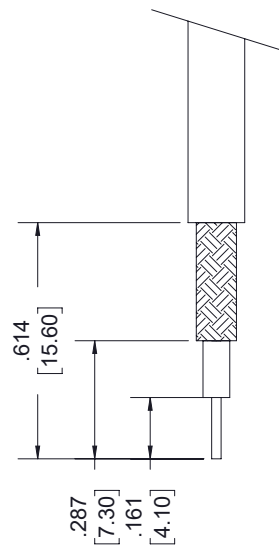
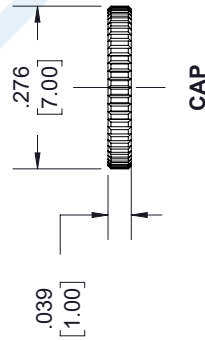
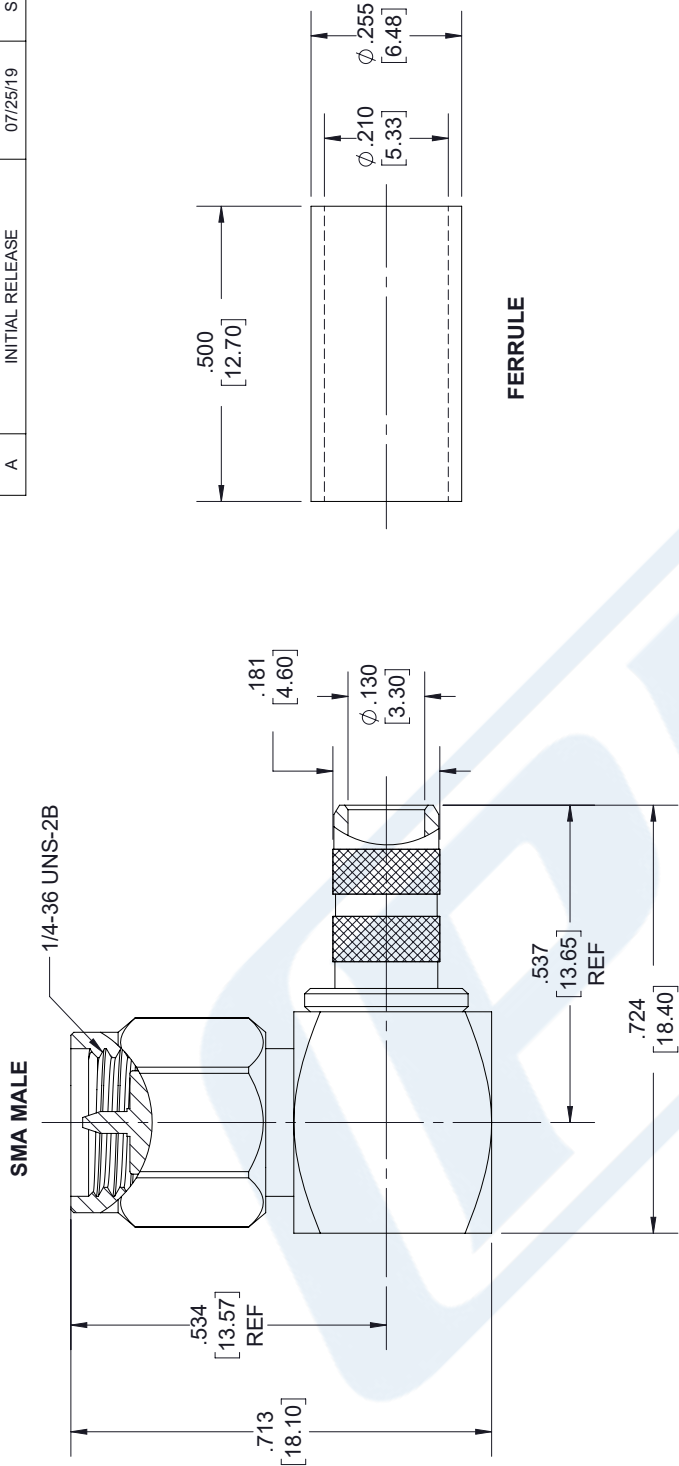

STRIPPING DIMENSIONS

NOTES:

- CABLE ATTACHMENT:
 - OUTER: CRIMP.
 - INNER: SOLDER.
- CRIMP SIZE REQUIRED:
 - FERRULE: .213 [5.41] HEX. CRIMP TOOL.

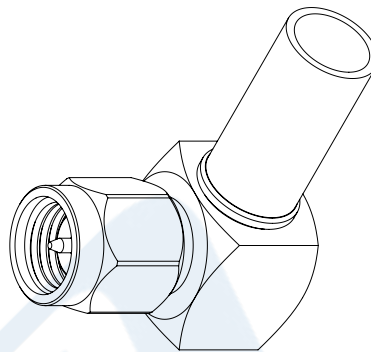

UNLESS OTHERWISE SPECIFIED LEADING DIMENSIONS ARE INCHES DIMENSIONS IN [] ARE MILLIMETERS	
TOLERANCES:	FRACTIONS
X±.2 [5.08]	±.132
.XX±.01 [0.25]	±.132
.XXX±.005 [0.13]	ANGLES ± 1°
ALL DIMENSIONS SHOWN ARE FOR REFERENCE ONLY.	
THIRD-ANGLE PROJECTION	

PE PASTERNAK
an INFINITO brand

Pasternack Enterprises, Inc.
P.O. Box 16759, Irvine, CA 92623.
Phone: 1.949.261.1920 | 1.866.727.8376
Fax: 1.949.261.7451
www.pasternack.com | e-mail: sales@pasternack.com

CAGE DRAWN BY PART NUMBER
A 53919 K.DANG PE45546

THE INFORMATION AND DESIGN IN THIS DOCUMENT IS THE PROPERTY OF PASTERNAK CORPORATION. ALL RIGHTS RESERVED.	
SHEET 1	OF 1
SCALE	N/A
REV	A

THESE COMMODITIES, TECHNOLOGY OR SOFTWARE WERE EXPORTED FROM THE UNITED STATES IN ACCORDANCE WITH THE EXPORT ADMINISTRATION REGULATIONS. DIVERSION CONTRARY TO U.S. LAW PROHIBITED.



Low Loss Flexible .200 inch Foam Dielectric Type Coax Cable Double Shielded with Black PE Jacket

TECHNICAL DATA SHEET

PE-C200

Low Loss Flexible .200 inch Foam Dielectric Type Coax Cable Double Shielded with Black PE Jacket

Configuration

Cable Design	Low Loss
Inner Conductor Material and Plating	Copper
Dielectric Type	PE (F)
Shield Materials	Aluminum Tape, Tinned Copper Braid
Jacket Material and Color	PE, Black

Electrical Specifications

Impedance, Ohms	50
Velocity of Propagation, %	83
Maximum Operating Frequency, GHz	5.8
RF Shielding, dB	90
Capacitance, pF/ft [pF/m]	24.5 [80.38]
Maximum Operating Voltage, Volts	1,000
Dielectric Withstanding Voltage, Vdc	1,000
Jacket Spark, Vrms	3,000
Peak Power, KWatts	2.5

Electrical Specifications by Frequency

Frequency 1

Frequency, MHz	50
Attenuation, dB/100ft [dB/100m]	2.3 [7.55]
Power Handling, Watts	790

Frequency 2

Frequency, MHz	150
Attenuation, dB/100ft [dB/100m]	4 [13.12]
Power Handling, Watts	450

Frequency 3

Frequency, GHz	1.5
Attenuation, dB/100ft [dB/100m]	12.9 [42.32]
Power Handling, Watts	140

Frequency 4

Frequency, GHz	2.5
Attenuation, dB/100ft [dB/100m]	16.9 [55.45]
Power Handling, Watts	110

Click the following link (or enter part number in "SEARCH" on website) to obtain additional part information including price, inventory and certifications: [Low Loss Flexible .200 inch Foam Dielectric Type Coax Cable Double Shielded with Black PE Jacket PE-C200](#)

The information contained in this document is accurate to the best of our knowledge and representative of the part described herein. It may be necessary to make modifications to the part and/or the documentation of the part, in order to implement improvements. Pasternack reserves the right to make such changes as required. Unless otherwise stated, all specifications are nominal.



Low Loss Flexible .200 inch Foam Dielectric Type Coax
 Cable Double Shielded with Black PE Jacket

TECHNICAL DATA SHEET

PE-C200

Frequency 5

Frequency, GHz	5.8
Attenuation, dB/100ft [dB/100m]	26.4 [86.61]
Power Handling, Watts	70

Mechanical Specifications

Temperature

Operating Range, deg C	-40 to +85
Storage Range, deg C	-70 to +85

Inner Conductor

Number of Strands	1
Material	Copper
Diameter, in [mm]	0.044 [1.12]

Dielectric:

Type	PE (F)
Diameter, in [mm]	0.116 [2.95]

Shield:

Number of	2
Material 1	Aluminum Tape
Material 2	Tinned Copper Braid
Diameter, in [mm]	0.144 [3.66]

Jacket:

Material	PE
Diameter, in [mm]	0.195 [4.95]
Color	Black
Weight, lbs/ft [Kg/m]	0.022 [0.03]

Compliance Certifications (visit www.Pasternack.com for current document)

RoHS Compliant	Yes
----------------	-----

Click the following link (or enter part number in "SEARCH" on website) to obtain additional part information including price, inventory and certifications: [Low Loss Flexible .200 inch Foam Dielectric Type Coax Cable Double Shielded with Black PE Jacket PE-C200](#)

The information contained in this document is accurate to the best of our knowledge and representative of the part described herein. It may be necessary to make modifications to the part and/or the documentation of the part, in order to implement improvements. Pasternack reserves the right to make such changes as required. Unless otherwise stated, all specifications are nominal.



Low Loss Flexible .200 inch Foam Dielectric Type Coax Cable Double Shielded with Black PE Jacket

TECHNICAL DATA SHEET

PE-C200

Plotted and Other Data

Notes:

Values at 25 °C, sea level

Low Loss Flexible .200 inch Foam Dielectric Type Coax Cable Double Shielded with Black PE Jacket from Pasternack Enterprises has same day shipment for domestic and International orders. Our RF, microwave and fiber optic products maintain a 99% availability and are part of the broadest selection in the industry.

Click the following link (or enter part number in "SEARCH" on website) to obtain additional part information including price, inventory and certifications: [Low Loss Flexible .200 inch Foam Dielectric Type Coax Cable Double Shielded with Black PE Jacket PE-C200](#)

URL: <http://www.pasternack.com/flexible-0.195-50-ohm-coax-cable-pe-jacket-pe-c200-p.aspx>

The information contained in this document is accurate to the best of our knowledge and representative of the part described herein. It may be necessary to make modifications to the part and/or the documentation of the part, in order to implement improvements. Pasternack reserves the right to make such changes as required. Unless otherwise stated, all specifications are nominal.

PE-C200 CAD Drawing

Low Loss Flexible .200 inch Foam Dielectric Type Coax
Cable Double Shielded with Black PE Jacket

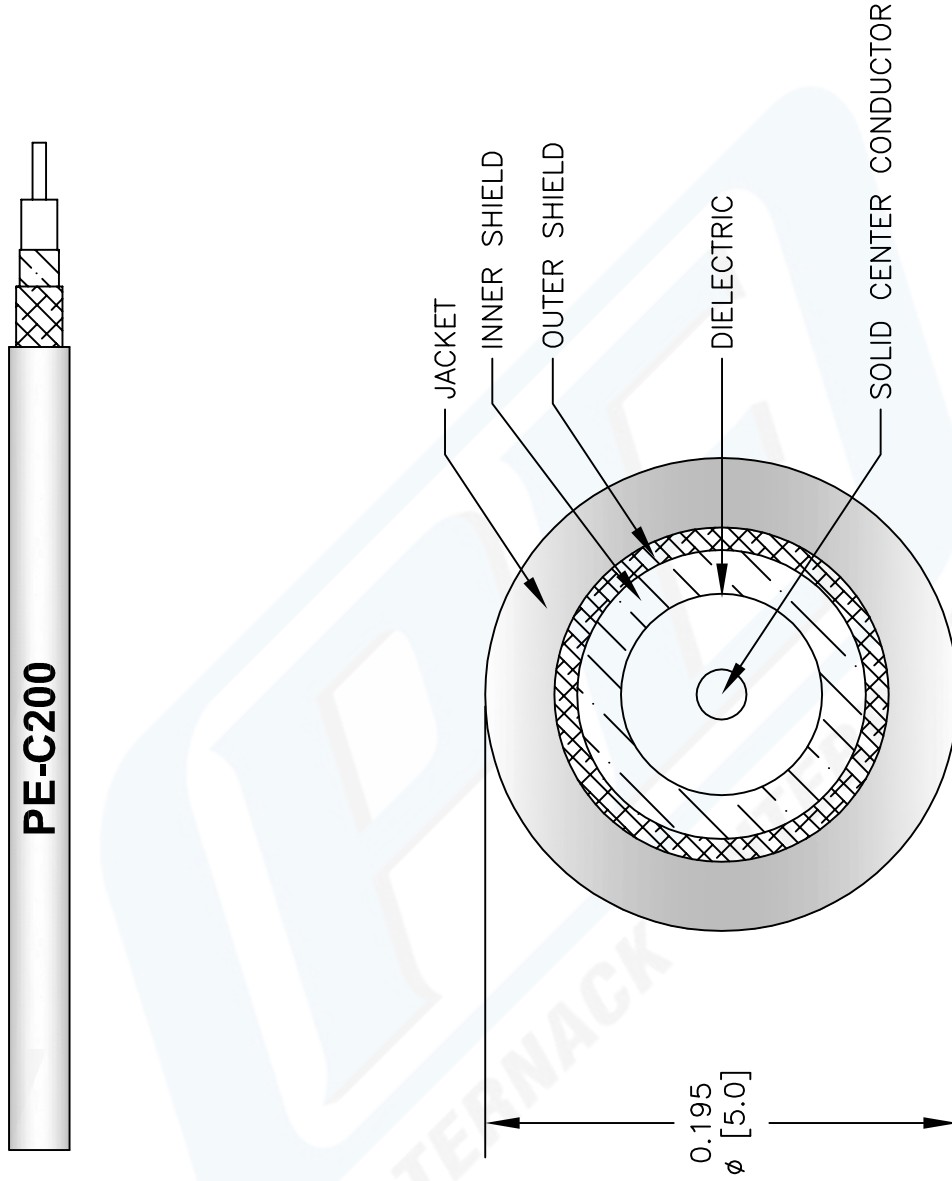

NOTES:
1. UNLESS OTHERWISE SPECIFIED ALL DIMENSIONS ARE NOMINAL.
2. ALL SPECIFICATIONS ARE SUBJECT TO CHANGE WITHOUT NOTICE AT ANY TIME.
3. DIMENSIONS ARE IN INCHES [mm].

DWG TITLE

PE-C200

FSCM NO. 53919

CAD FILE 040113-A

SCALE N/A

SIZE A

127



PASTERNAK®
Pasternack Enterprises, Inc.
P.O. Box 16759 | Irvine | CA | 92623

Phone: (949) 261-1920 | Fax: (949) 261-7451

Website: www.pasternack.com | E-Mail: sales@pasternack.com