



BMA Jack Snap-On Connector Crimp/Solder Attachment for RG142, RG223, RG400, RG55

RF Connectors Technical Data Sheet

PE45320

Configuration

- Snap-On BMA Jack Connector
- 50 Ohms
- Straight Body Geometry
- RG142, RG223, RG400, RG55 Interface Type
- Crimp/Solder Attachment

Features

- Max. Operating Frequency 12.4 GHz
- Good VSWR of 1.28:1
- Gold Plated Beryllium Copper Contact
- 51.18µ in. minimum contact plating
- Blind Mate Connector
- Low-Engagement Force
- Radial and Axial Float Versions

Applications

- General Purpose Test
- Custom Cable Assemblies
- Blind Mating
- Rack and Panel
- Phased Array Systems
- Base Stations
- RF Backplanes
- Test I/O

Description

Pasternack's PE45320 BMA jack snap-on connector with crimp/solder attachment for RG142, RG223, RG400 and RG55 is part of our full line of RF components available for same-day shipping. Our BMA jack connector operates up to a maximum frequency of 12.4 GHz and offers good VSWR of 1.28:1. The Pasternack blind mate connector is ideal for applications where direct visual or tactile access to the connection point is not possible, for example, when two circuit boards need to be mated.

Our BMA jack connector PE45320 datasheet specifications and drawing with dimensions are shown below in this PDF. Pasternack's broad catalog of RF, microwave and millimeter wave connectors allows designers to configure and customize their signal connections however they like. Whether the need is to provide an I/O for a board design, or simply create a custom cable assembly configuration, Pasternack has the right connector for the job. Pasternack can also expertly build your custom cable assemblies for you and ship same-day.

Electrical Specifications

Description	Minimum	Typical	Maximum	Units
Frequency Range	DC		12.4	GHz
VSWR			1.28:1	
Insertion Loss			0.1	dB
Operating Voltage (AC)			350	Vrms
Dielectric Withstanding Voltage (AC)			1,000	Vrms
Insulation Resistance	5,000			MOhms

Click the following link (or enter part number in "SEARCH" on website) to obtain additional part information including price, inventory and certifications: [BMA Jack Snap-On Connector Crimp/Solder Attachment for RG142, RG223, RG400, RG55 PE45320](#)



BMA Jack Snap-On Connector Crimp/Solder Attachment for RG142, RG223, RG400, RG55

RF Connectors Technical Data Sheet

PE45320

Mechanical Specifications

Size

Length	0.97 in [24.64 mm]
Width/Dia.	0.35 in [8.89 mm]
Weight	0.007 lbs [3.18 g]
Mating Cycles	1,000 Cycles

Material Specifications

Description	Material	Plating
Contact	Beryllium Copper	Gold 51.18µ in. minimum
Outer Conductor	Beryllium Copper	Gold
Body	Passivated Stainless Steel	

Mechanical Specification Notes:

Recommended axial float mount for best electrical performance: 0.51 +/- 0.25 mm (.020" +/- .010)

Environmental Specifications

Temperature

Operating Range	-55 to +165 deg C
-----------------	-------------------

Click the following link (or enter part number in "SEARCH" on website) to obtain additional part information including price, inventory and certifications: [BMA Jack Snap-On Connector Crimp/Solder Attachment for RG142, RG223, RG400, RG55 PE45320](#)



BMA Jack Snap-On Connector Crimp/Solder Attachment for RG142, RG223, RG400, RG55

RF Connectors Technical Data Sheet

PE45320

Compliance Certifications (see [product page](#) for current document)

Plotted and Other Data

Notes:

BMA Jack Snap-On Connector Crimp/Solder Attachment for RG142, RG223, RG400, RG55 from Pasternack Enterprises has same day shipment for domestic and International orders. Our RF, microwave and millimeter wave products maintain a 99.4% availability and are part of the broadest selection in the industry.

Click the following link (or enter part number in "SEARCH" on website) to obtain additional part information including price, inventory and certifications: [BMA Jack Snap-On Connector Crimp/Solder Attachment for RG142, RG223, RG400, RG55 PE45320](#)

URL: <https://www.pasternack.com/bma-jack-snap-on-rg142-rg223-rg400-rg55-connector-pe45320-p.aspx>

The information contained in this document is accurate to the best of our knowledge and representative of the part described herein. It may be necessary to make modifications to the part and/or the documentation of the part, in order to implement improvements. Pasternack reserves the right to make such changes as required. Unless otherwise stated, all specifications are nominal. Pasternack does not make any representation or warranty regarding the suitability of the part described herein for any particular purpose, and Pasternack does not assume any liability arising out of the use of any part or documentation.

PE45320 CAD Drawing

BMA Jack Snap-On Connector Crimp/Solder Attachment
for RG142, RG223, RG400, RG55

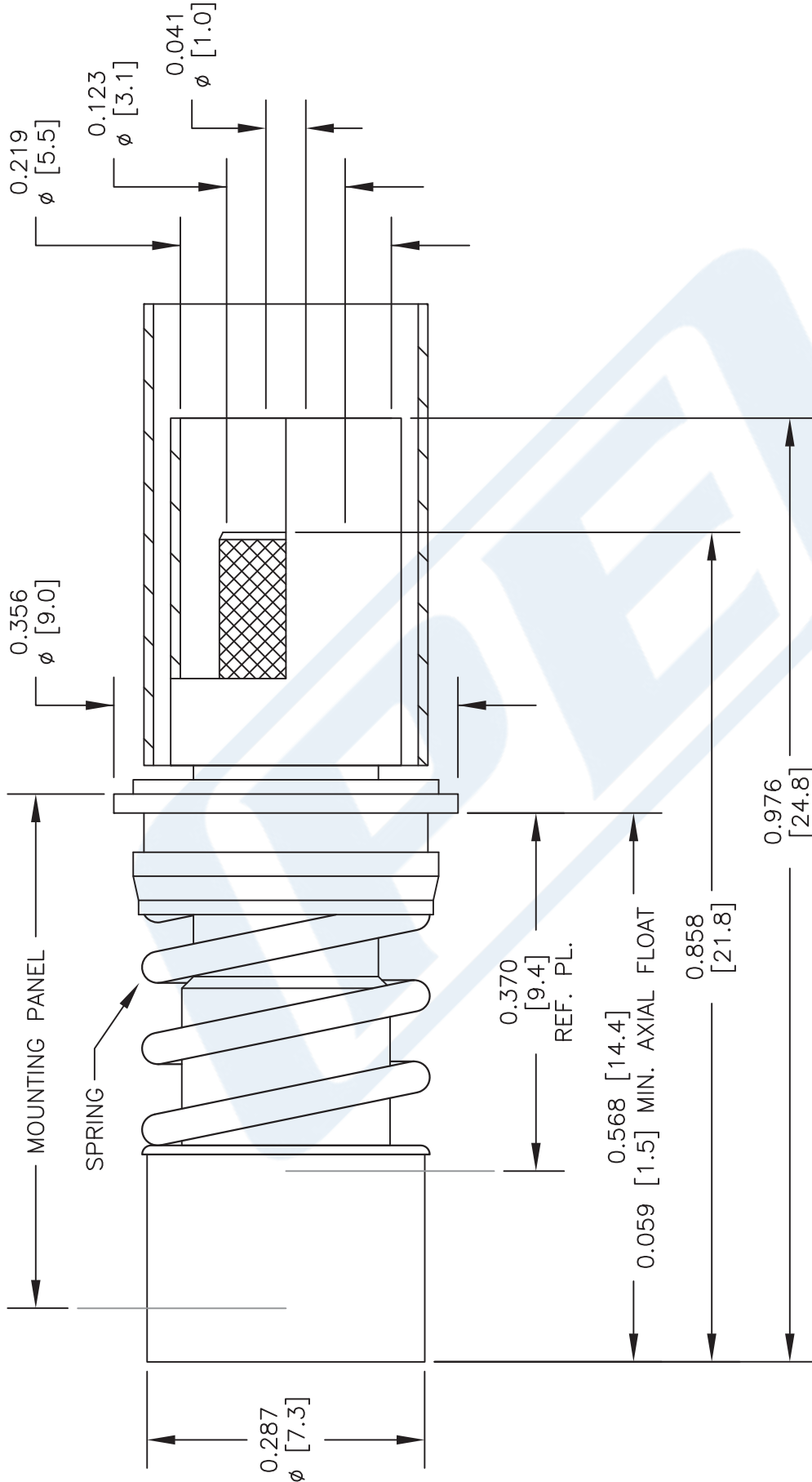

STANDARD TOLERANCES

.X ± 0.2
.XX ± 0.1
.XXX ± 0.05

*STANDARD TOLERANCES APPLY
ONLY TO DIMENSIONS IN INCHES

NOTES:

1. UNLESS OTHERWISE SPECIFIED ALL DIMENSIONS ARE NOMINAL.
2. ALL SPECIFICATIONS ARE SUBJECT TO CHANGE WITHOUT NOTICE AT ANY TIME.
3. DIMENSIONS ARE IN INCHES [mm].

DWG TITLE

PE45320

CAGE CODE 53919

CAD FILE 022017

SCALE N/A

SIZE A

2233



Pasternack Enterprises, Inc.
P.O. Box 16759 | Irvine | CA | 92623
Phone: (949) 261-1920 | Fax: (949) 261-7451
Website: www.pasternack.com | E-Mail: sales@pasternack.com

PE45320 CAD Drawing

BMA Jack Snap-On Connector Crimp/Solder Attachment
for RG142, RG223, RG400, RG55

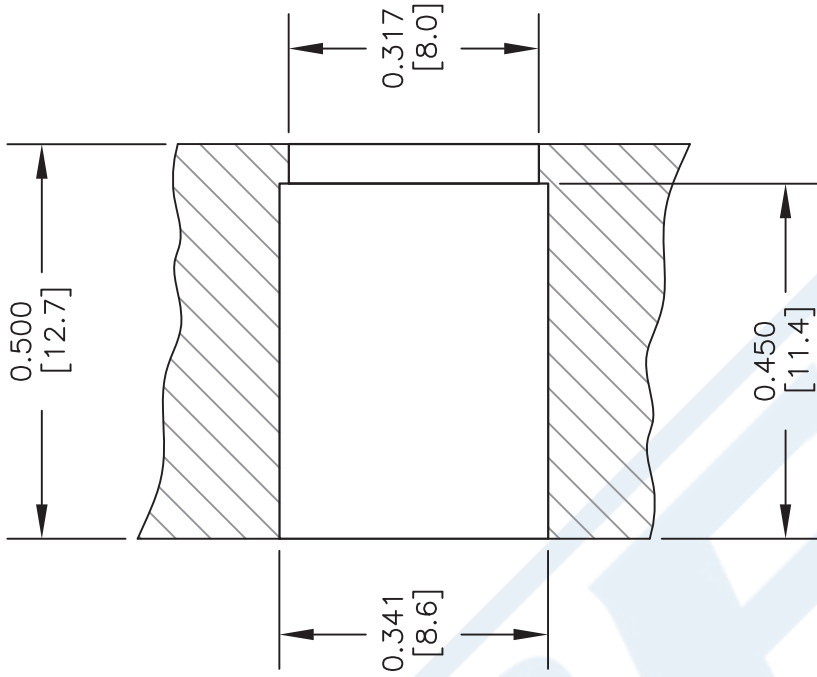

PANEL DRILLING

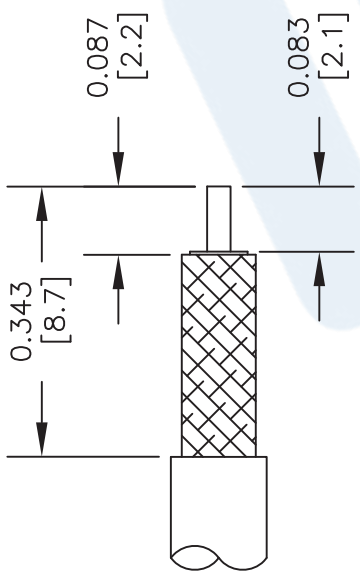

STRIPPING DIMENSIONS

ASSEMBLY PROCEDURES

1. STRIP CABLE TO THE DIMENSIONS SHOWN, DO NOT NICK CENTER CONDUCTOR OR BRAID.
2. SLIDE HEAT SHRINK AND FERRULE ONTO CABLE.
3. PUSH CENTER CONDUCTOR FULLY INTO CONTACT AND SOLDER, REMOVE ANY EXCESS SOLDER.
4. FLARE BRAID AND INSERT CONTACT INTO THE BODY UNTIL IT SEATS.
5. SLIDE FERRULE OVER BRAID AND CRIMP WITH .213" HEX CRIMP TOOL.

STANDARD TOLERANCES	
.X	±0.2
.XX	±0.1
.XXX	±0.05

*STANDARD TOLERANCES APPLY ONLY TO DIMENSIONS IN INCHES

PE PASTERNAK®
THE ENGINEER'S RF SOURCE
Pasternack Enterprises, Inc.
P.O. Box 16759 | Irvine | CA | 92623
Phone: (949) 261-1920 | Fax: (949) 261-7451
Website: www.pasternack.com | E-Mail: sales@pasternack.com

DWG TITLE
PE45320

CAGE CODE **53919**

NOTES:
1. UNLESS OTHERWISE SPECIFIED ALL DIMENSIONS ARE NOMINAL.
2. ALL SPECIFICATIONS ARE SUBJECT TO CHANGE WITHOUT NOTICE AT ANY TIME.
3. DIMENSIONS ARE IN INCHES [mm].

CAD FILE 022017

SCALE N/A

SIZE A

2233



BMA Jack Snap-On Connector Crimp/Solder Attachment for RG142, RG223, RG400, RG55

RF Connectors Technical Data Sheet

PE45320

Configuration

- Snap-On BMA Jack Connector
- 50 Ohms
- Straight Body Geometry
- RG142, RG223, RG400, RG55 Interface Type
- Crimp/Solder Attachment

Features

- Max. Operating Frequency 12.4 GHz
- Good VSWR of 1.28:1
- Gold Plated Beryllium Copper Contact
- 51.18µ in. minimum contact plating
- Blind Mate Connector
- Low-Engagement Force
- Radial and Axial Float Versions

Applications

- General Purpose Test
- Custom Cable Assemblies
- Blind Mating
- Rack and Panel
- Phased Array Systems
- Base Stations
- RF Backplanes
- Test I/O

Description

Pasternack's PE45320 BMA jack snap-on connector with crimp/solder attachment for RG142, RG223, RG400 and RG55 is part of our full line of RF components available for same-day shipping. Our BMA jack connector operates up to a maximum frequency of 12.4 GHz and offers good VSWR of 1.28:1. The Pasternack blind mate connector is ideal for applications where direct visual or tactile access to the connection point is not possible, for example, when two circuit boards need to be mated.

Our BMA jack connector PE45320 datasheet specifications and drawing with dimensions are shown below in this PDF. Pasternack's broad catalog of RF, microwave and millimeter wave connectors allows designers to configure and customize their signal connections however they like. Whether the need is to provide an I/O for a board design, or simply create a custom cable assembly configuration, Pasternack has the right connector for the job. Pasternack can also expertly build your custom cable assemblies for you and ship same-day.

Electrical Specifications

Description	Minimum	Typical	Maximum	Units
Frequency Range	DC		12.4	GHz
VSWR			1.28:1	
Insertion Loss			0.1	dB
Operating Voltage (AC)			350	Vrms
Dielectric Withstanding Voltage (AC)			1,000	Vrms
Insulation Resistance	5,000			MOhms

Click the following link (or enter part number in "SEARCH" on website) to obtain additional part information including price, inventory and certifications: [BMA Jack Snap-On Connector Crimp/Solder Attachment for RG142, RG223, RG400, RG55 PE45320](#)



BMA Jack Snap-On Connector Crimp/Solder Attachment for RG142, RG223, RG400, RG55

RF Connectors Technical Data Sheet

PE45320

Mechanical Specifications

Size

Length	0.97 in [24.64 mm]
Width/Dia.	0.35 in [8.89 mm]
Weight	0.007 lbs [3.18 g]
Mating Cycles	1,000 Cycles

Material Specifications

Description	Material	Plating
Contact	Beryllium Copper	Gold 51.18μ in. minimum
Outer Conductor	Beryllium Copper	Gold
Body	Passivated Stainless Steel	

Mechanical Specification Notes:

Recommended axial float mount for best electrical performance: 0.51 +/- 0.25 mm (.020" +/- .010)

Environmental Specifications

Temperature

Operating Range	-55 to +165 deg C
-----------------	-------------------

Click the following link (or enter part number in "SEARCH" on website) to obtain additional part information including price, inventory and certifications: [BMA Jack Snap-On Connector Crimp/Solder Attachment for RG142, RG223, RG400, RG55 PE45320](#)



BMA Jack Snap-On Connector Crimp/Solder Attachment for RG142, RG223, RG400, RG55

RF Connectors Technical Data Sheet

PE45320

Compliance Certifications (see [product page](#) for current document)

Plotted and Other Data

Notes:

BMA Jack Snap-On Connector Crimp/Solder Attachment for RG142, RG223, RG400, RG55 from Pasternack Enterprises has same day shipment for domestic and International orders. Our RF, microwave and millimeter wave products maintain a 99.4% availability and are part of the broadest selection in the industry.

Click the following link (or enter part number in "SEARCH" on website) to obtain additional part information including price, inventory and certifications: [BMA Jack Snap-On Connector Crimp/Solder Attachment for RG142, RG223, RG400, RG55 PE45320](#)

URL: <https://www.pasternack.com/bma-jack-snap-on-rg142-rg223-rg400-rg55-connector-pe45320-p.aspx>

The information contained in this document is accurate to the best of our knowledge and representative of the part described herein. It may be necessary to make modifications to the part and/or the documentation of the part, in order to implement improvements. Pasternack reserves the right to make such changes as required. Unless otherwise stated, all specifications are nominal. Pasternack does not make any representation or warranty regarding the suitability of the part described herein for any particular purpose, and Pasternack does not assume any liability arising out of the use of any part or documentation.

PE45320 CAD Drawing

BMA Jack Snap-On Connector Crimp/Solder Attachment
for RG142, RG223, RG400, RG55

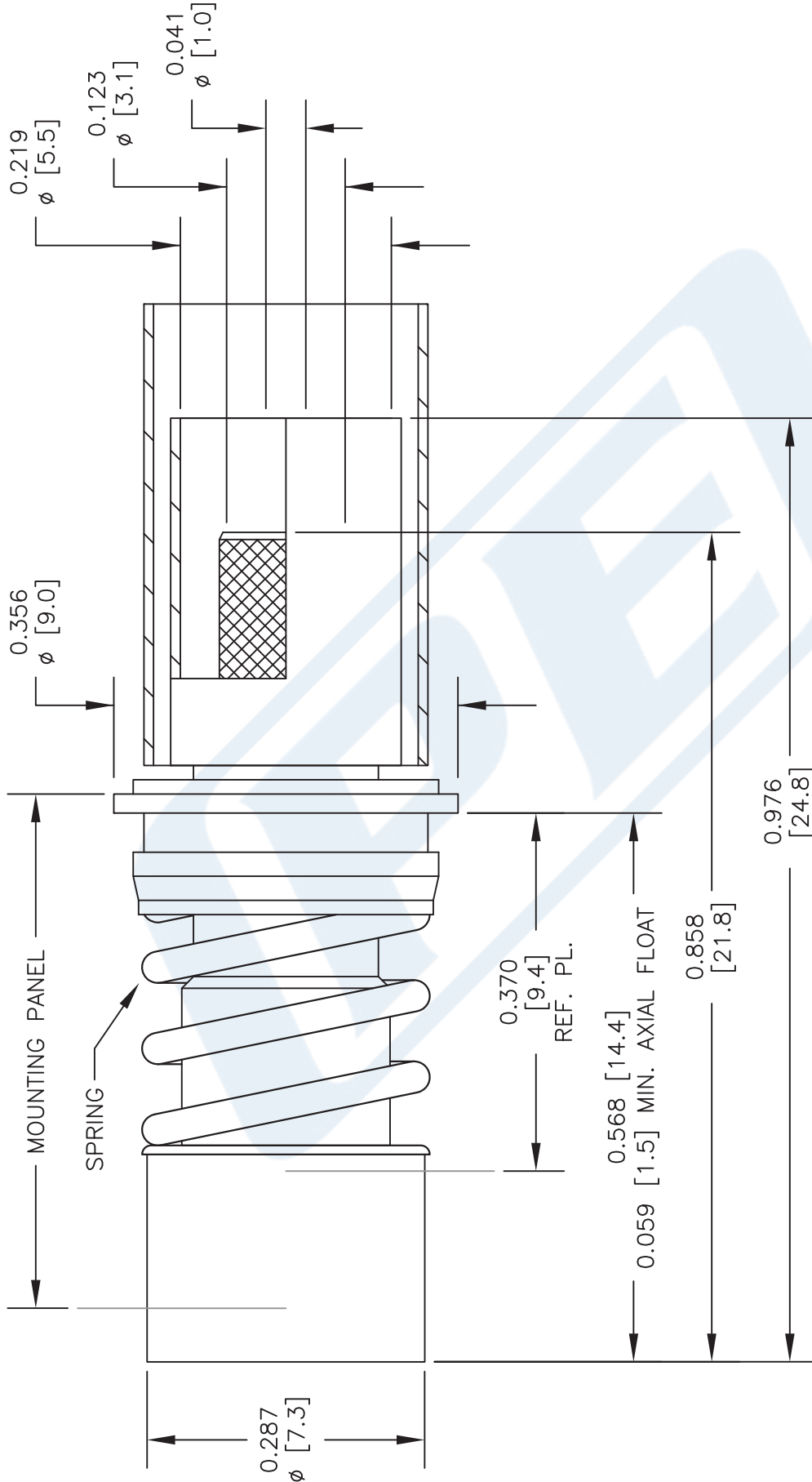

STANDARD TOLERANCES

.X ± 0.2
.XX ± 0.1
.XXX ± 0.05

*STANDARD TOLERANCES APPLY
ONLY TO DIMENSIONS IN INCHES

NOTES:

1. UNLESS OTHERWISE SPECIFIED ALL DIMENSIONS ARE NOMINAL.
2. ALL SPECIFICATIONS ARE SUBJECT TO CHANGE WITHOUT NOTICE AT ANY TIME.
3. DIMENSIONS ARE IN INCHES [mm].

DWG TITLE

PE45320

(PE) PASTERNAK®
THE ENGINEER'S RF SOURCE
Pasternack Enterprises, Inc.
P.O. Box 16759 | Irvine | CA | 92623
Phone: (949) 261-1920 | Fax: (949) 261-7451
Website: www.pasternack.com | E-Mail: sales@pasternack.com

CAGE CODE 53919

CAD FILE 022017

SCALE N/A

SIZE A

2233

PE45320 CAD Drawing

BMA Jack Snap-On Connector Crimp/Solder Attachment
for RG142, RG223, RG400, RG55

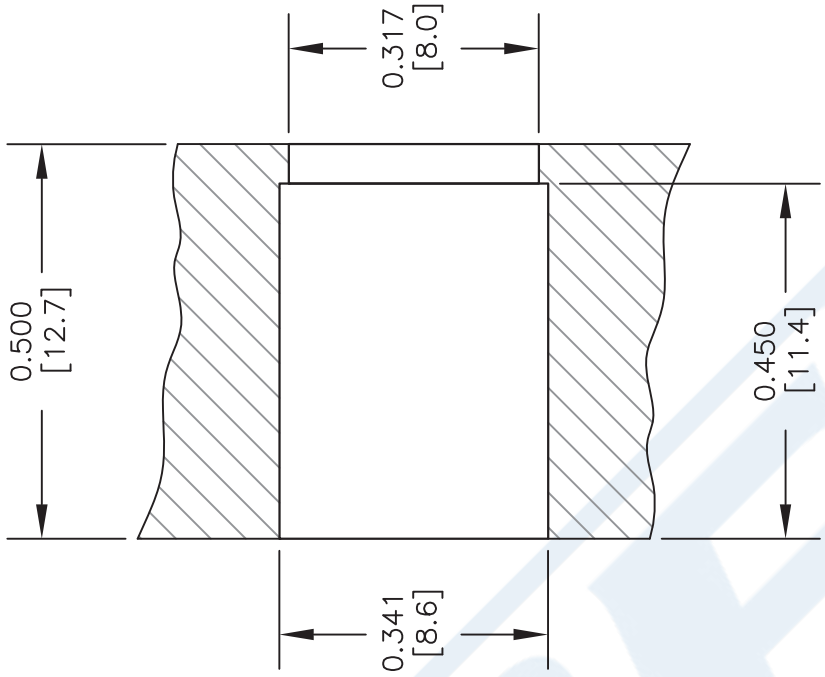

PANEL DRILLING

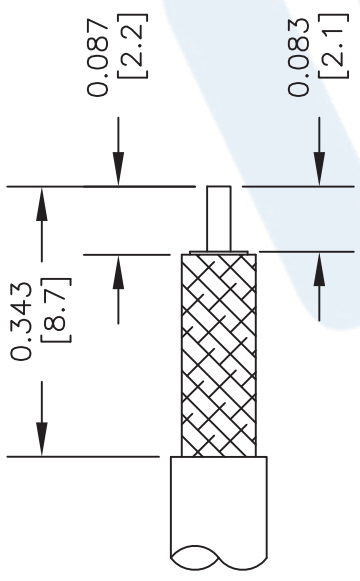

STRIPPING DIMENSIONS

ASSEMBLY PROCEDURES

1. STRIP CABLE TO THE DIMENSIONS SHOWN, DO NOT NICK CENTER CONDUCTOR OR BRAID.
2. SLIDE HEAT SHRINK AND FERRULE ONTO CABLE.
3. PUSH CENTER CONDUCTOR FULLY INTO CONTACT AND SOLDER, REMOVE ANY EXCESS SOLDER.
4. FLARE BRAID AND INSERT CONTACT INTO THE BODY UNTIL IT SEATS.
5. SLIDE FERRULE OVER BRAID AND CRIMP WITH .213" HEX CRIMP TOOL.

STANDARD TOLERANCES	
.X	±0.2
.XX	±0.1
.XXX	±0.05

*STANDARD TOLERANCES APPLY ONLY TO DIMENSIONS IN INCHES

<p>NOTES:</p> <ol style="list-style-type: none"> 1. UNLESS OTHERWISE SPECIFIED ALL DIMENSIONS ARE NOMINAL. 2. ALL SPECIFICATIONS ARE SUBJECT TO CHANGE WITHOUT NOTICE AT ANY TIME. 3. DIMENSIONS ARE IN INCHES [mm]. 	
<p>DWG TITLE</p> <h1>PE45320</h1>	
<p>CAGE CODE</p> <h2>53919</h2>	<p>CAD FILE</p> <p>022017</p>
<p>SCALE</p> <p>N/A</p>	<p>SIZE</p> <p>A</p>
<p>2233</p>	

PE PASTERNAK®
THE ENGINEER'S RF SOURCE
Pasternack Enterprises, Inc.
P.O. Box 16759 | Irvine | CA | 92623
Phone: (949) 261-1920 | Fax: (949) 261-7451
Website: www.pasternack.com | E-Mail: sales@pasternack.com



Flexible RG223 Coax Cable Double Shielded with Black PVC Jacket

TECHNICAL DATA SHEET

RG223/U

Configuration

Inner Conductor Material and Plating	Copper, Silver
Dielectric Type	PE
Shield Materials	Silver Plated Copper Braid, Silver Plated Copper Braid
Jacket Material and Color	PVC, Black

Electrical Specifications

Impedance, Ohms	50
Velocity of Propagation, %	66
Maximum Operating Frequency, GHz	12.4
Capacitance, pF/ft [pF/m]	30.8 [101.05]
Maximum Operating Voltage, Volts	1,900

Electrical Specifications by Frequency

Frequency 1

Frequency, MHz	100
Attenuation, dB/100ft [dB/100m]	4 [13.12]

Frequency 2

Frequency, MHz	400
Attenuation, dB/100ft [dB/100m]	8.2 [26.9]

Frequency 3

Frequency, MHz	1000
Attenuation, dB/100ft [dB/100m]	13.4 [43.96]

Frequency 4

Frequency, GHz	3
Attenuation, dB/100ft [dB/100m]	24.8 [81.36]

Frequency 5

Frequency, GHz	5
Attenuation, dB/100ft [dB/100m]	33.5 [109.91]

Frequency 6

Frequency, GHz	11
Attenuation, dB/100ft [dB/100m]	54.1 [177.49]

Mechanical Specifications

Temperature

Operating Range, deg C	-20 to +80
------------------------	------------

Click the following link (or enter part number in "SEARCH" on website) to obtain additional part information including price, inventory and certifications: [Flexible RG223 Coax Cable Double Shielded with Black PVC Jacket RG223/U](#)



Flexible RG223 Coax Cable Double
Shielded with Black PVC Jacket

TECHNICAL DATA SHEET

RG223/U

Inner Conductor

Number of Strands	1
Material	Copper
Plating	Silver
Diameter, in [mm]	0.035 [0.89]

Dielectric:

Type	PE
Diameter, in [mm]	0.116 [2.95]

Shield:

Number of	2
Material 1	Silver Plated Copper Braid
Material 2	Silver Plated Copper Braid
Diameter, in [mm]	0.156 [3.96]

Jacket:

Material	PVC
Diameter, in [mm]	0.21 [5.33]
Color	Black
One Time Minimum Bend Radius, in [mm]	0.21 [5.33]
Repeated Minimum Bend Radius, in [mm]	1 [25.4]
Weight, lbs/ft [Kg/m]	0.038 [0.06]

Compliance Certifications (visit www.Pasternack.com for current document)

RoHS Compliant	
REACH Compliant	06/18/2012

Plotted and Other Data

Notes:

- Values at +25 °C, sea level

Flexible RG223 Coax Cable Double Shielded with Black PVC Jacket from Pasternack Enterprises has same day shipment for domestic and International orders. Our RF, microwave and millimeter wave products maintain a 99% availability and are part of the broadest selection in the industry.

Click the following link (or enter part number in "SEARCH" on website) to obtain additional part information including price, inventory and certifications: [Flexible RG223 Coax Cable Double Shielded with Black PVC Jacket RG223/U](#)

URL: <http://www.pasternack.com/flexible-0.216-rg223-50-ohm-coax-cable-pvc-jacket-rg223-u-p.aspx>

The information contained in this document is accurate to the best of our knowledge and representative of the part described herein. It may be necessary to make modifications to the part and/or the documentation of the part, in order to implement improvements. Pasternack reserves the right to make such changes as required. Unless otherwise stated, all specifications are nominal. Pasternack does not make any representation or warranty regarding the suitability of the part described herein for any particular purpose, and Pasternack does not assume any liability arising out of the use of any part or documentation.

RG223/U CAD Drawing

Flexible RG223 Coax Cable Double Shielded with Black PVC Jacket

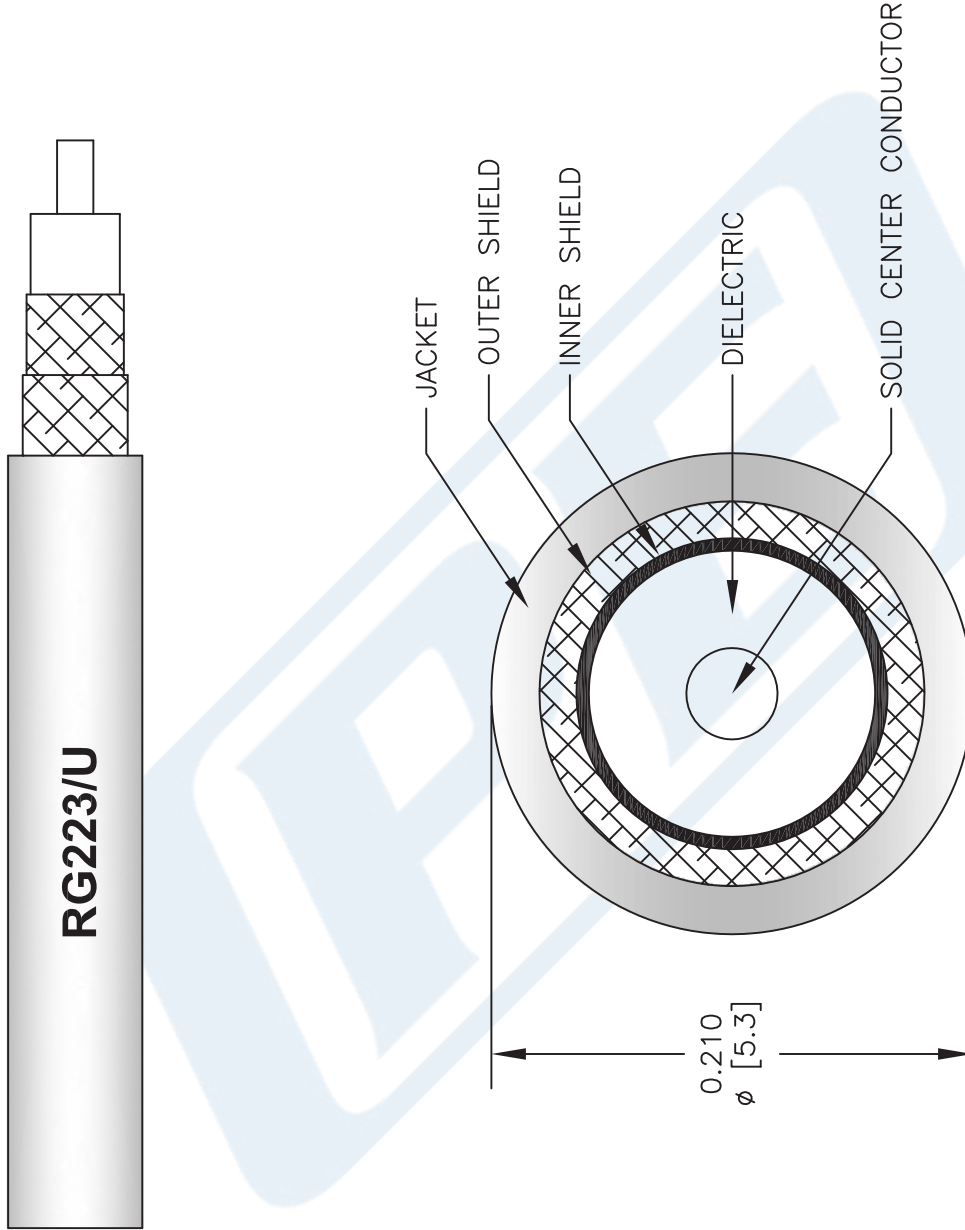

NOTES:
 1. UNLESS OTHERWISE SPECIFIED ALL DIMENSIONS ARE NOMINAL.
 2. ALL SPECIFICATIONS ARE SUBJECT TO CHANGE WITHOUT NOTICE AT ANY TIME.
 3. DIMENSIONS ARE IN INCHES [mm].

DWG TITLE
RG223/U

FSCM NO. 53919

2233

SIZE A

SCALE N/A

CAD FILE 060508-B

PE PASTERNAK®
 Pasternack Enterprises, Inc.
 P.O. Box 16759 | Irvine | CA | 92623
Phone: (949) 261-1920 | **Fax:** (949) 261-7451
Website: www.pasternack.com | **E-Mail:** sales@pasternack.com