



UHF Male Connector Clamp/Solder Attachment  
for RG58, RG55, RG141, RG142, RG223, RG400,  
RG303, PE-C195, PE-P195, LMR-195

## RF Connectors Technical Data Sheet

**PE44052**

### Configuration

- UHF Male Connector
- 50 Ohms
- Straight Body Geometry
- Connector Interface Types: RG58, RG55, RG141, RG142, RG223, RG400, RG303, PE-C195, PE-P195, LMR-195

### Features

- Max. Operating Frequency 300 MHz
- Gold Plated Brass Contact

### Applications

- General Purpose Test
- Custom Cable Assemblies

### Description

Pasternack's PE44052 UHF male connector with clamp/solder attachment for RG58, RG55, RG141, RG142, RG223, RG400, RG303, PE-C195, PE-P195 and LMR-195 is part of our full line of RF components available for same-day shipping. Our UHF male connector operates up to a maximum frequency of 300 MHz.

Our UHF male connector PE44052 datasheet specifications and drawing with dimensions are shown below in this PDF. Pasternack's broad catalog of RF, microwave and millimeter wave connectors allows designers to configure and customize their signal connections however they like. Whether the need is to provide an I/O for a board design, or simply create a custom cable assembly configuration, Pasternack has the right connector for the job. Pasternack can also expertly build your custom cable assemblies for you and ship same-day.

### Electrical Specifications

Description	Minimum	Typical	Maximum	Units
Frequency Range	DC		300	MHz
Operating Voltage (AC)			500	Vrms
Dielectric Withstanding Voltage (AC)			1,500	Vrms

### Mechanical Specifications

<b>Size</b>	
Length	1.26 in [32 mm]
Width/Dia.	0.7 in [17.78 mm]
Weight	0.054 lbs [24.49 g]

Click the following link (or enter part number in "SEARCH" on website) to obtain additional part information including price, inventory and certifications: [UHF Male Connector Clamp/Solder Attachment for RG58, RG55, RG141, RG142, RG223, RG400, RG303, PE-C195, PE-P195, LMR-195 PE44052](#)



UHF Male Connector Clamp/Solder Attachment  
for RG58, RG55, RG141, RG142, RG223, RG400,  
RG303, PE-C195, PE-P195, LMR-195

## RF Connectors Technical Data Sheet

**PE44052**

### Material Specifications

Description	Material	Plating
Contact	Brass	Gold
Insulation	PTFE	
Body	Brass	Nickel 100 µin minimum
Coupling Nut	Brass	Nickel 100 µin minimum

### Mechanical Specification Notes:

When attaching the connector to the cable use a clamp torque value of 26 to 30 in-lbs [2.94 to 3.39 Nm]

### Environmental Specifications

#### Temperature

Operating Range

-55 to +85 deg C

### Compliance Certifications (see [product page](#) for current document)

### Plotted and Other Data

Notes:

UHF Male Connector Clamp/Solder Attachment for RG58, RG55, RG141, RG142, RG223, RG400, RG303, PE-C195, PE-P195, LMR-195 from Pasternack Enterprises has same day shipment for domestic and International orders. Our RF, microwave and millimeter wave products maintain a 99.4% availability and are part of the broadest selection in the industry.

Click the following link (or enter part number in "SEARCH" on website) to obtain additional part information including price, inventory and certifications: [UHF Male Connector Clamp/Solder Attachment for RG58, RG55, RG141, RG142, RG223, RG400, RG303, PE-C195, PE-P195, LMR-195 PE44052](#)

URL: <https://www.pasternack.com/uhf-male-standard-rg58-rg55-rg141-rg142-rg223-rg400-connector-pe44052-p.aspx>

The information contained in this document is accurate to the best of our knowledge and representative of the part described herein. It may be necessary to make modifications to the part and/or the documentation of the part, in order to implement improvements. Pasternack reserves the right to make such changes as required. Unless otherwise stated, all specifications are nominal. Pasternack does not make any representation or warranty regarding the suitability of the part described herein for any particular purpose, and Pasternack does not assume any liability arising out of the use of any part or documentation.

# PE44052 CAD Drawing

UHF Male Connector Clamp/Solder Attachment for RG58, RG55, RG141, RG142, RG223, RG400, RG303, PE-C195, PE-P195, LMR-195

REVISIONS		
REV.	DESCRIPTION	DATE
A	PCR PE44052 20200817	10/20/20

## ASSEMBLY PROCEDURES



1. SLIDE CLAMP NUT (1) & GASKET (2) OVER CABLE. STRIP CABLE AS SHOWN BELOW.

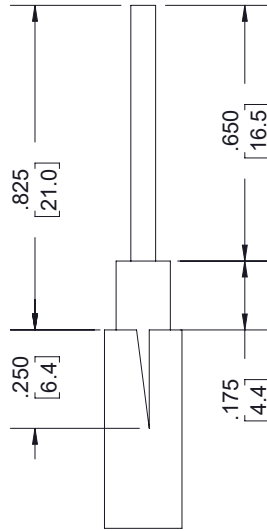

## STRIPPING DIMENSIONS

2. INSERT BRAID CLAMP (3) BETWEEN BRAID & DIELECTRIC. INSERT ASSEMBLY INTO BODY. THEN SOLDER CENTER CONDUCTOR TO CONTACT AND TIGHTEN.

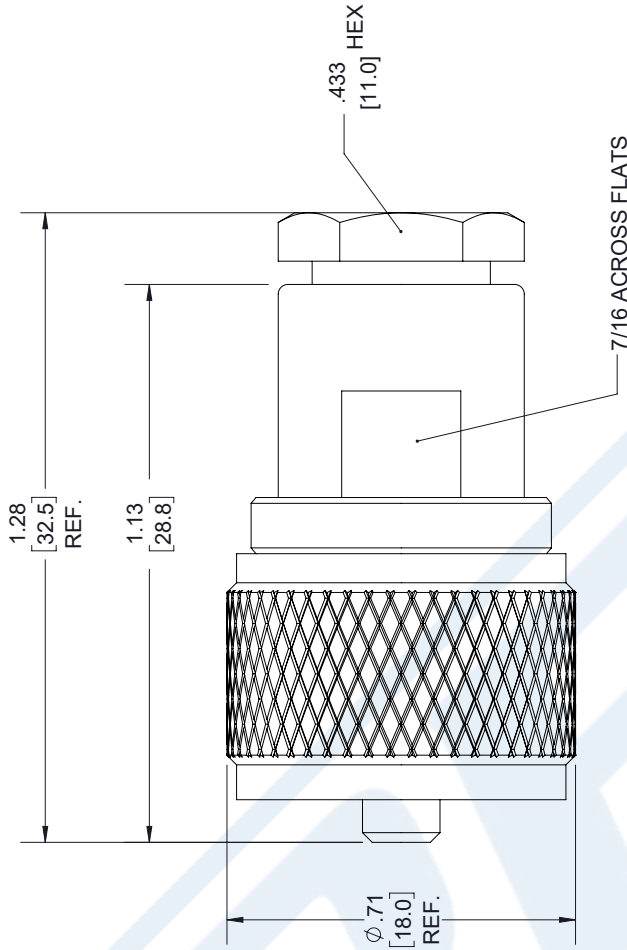

UNLESS OTHERWISE SPECIFIED LEADING DIMENSIONS ARE INCHES DIMENSIONS IN [ ] ARE MILLIMETERS

TOLERANCES:  
 .X = ±.2 [5.08] FRACTIONS ± 1/32  
 .XX = ±.02 [.51] ANGLES ± 1°  
 .XXX = ±.005 [.13]  
 CABLE LENGTH (L) TOLERANCES:  
 L ≤ 12 [305] = +1 [25] / -0  
 12 [305] < L ≤ 60 [1524] = +2 [51] / -0  
 60 [1524] < L ≤ 120 [3048] = +4 [102] / -0  
 120 [3048] < L ≤ 300 [7620] = +6 [152] / -0  
 300 [7620] < L = +5%L / -0  
 ALL DIMENSIONS SHOWN ARE FOR REFERENCE ONLY.



Pasternack Enterprises, Inc.  
 P.O. Box 16759, Irvine, CA 92623.  
 Phone: 1.949.261.1920 | 1.866.727.8376  
 Fax: 1.949.261.7451  
 Website: www.pasternack.com  
 E-mail: sales@pasternack.com



THIRD-ANGLE PROJECTION  
 THE INFORMATION AND DESIGN ARE THE PROPERTY OF PASTERNAK CORPORATION ALL RIGHTS RESERVED.

SHEET 1 OF 1  
 SCALE N/A

REV	ITEM NO.	SCALE	SHEET	OF
A	53919	SLI	1	1

SIZE	CAGE CODE	DRAWN BY	ITEM NO.
A	53919	SLI	PE44052

THESE COMMODITIES, TECHNOLOGY OR SOFTWARE WERE EXPORTED FROM THE UNITED STATES IN ACCORDANCE WITH THE EXPORT ADMINISTRATION REGULATIONS. DIVERSION CONTRARY TO U.S. LAW PROHIBITED.



UHF Male Connector Clamp/Solder Attachment  
for RG58, RG55, RG141, RG142, RG223, RG400,  
RG303, PE-C195, PE-P195, LMR-195

## RF Connectors Technical Data Sheet

**PE44052**

### Configuration

- UHF Male Connector
- 50 Ohms
- Straight Body Geometry
- Connector Interface Types: RG58, RG55, RG141, RG142, RG223, RG400, RG303, PE-C195, PE-P195, LMR-195

### Features

- Max. Operating Frequency 300 MHz
- Gold Plated Brass Contact

### Applications

- General Purpose Test
- Custom Cable Assemblies

### Description

Pasternack's PE44052 UHF male connector with clamp/solder attachment for RG58, RG55, RG141, RG142, RG223, RG400, RG303, PE-C195, PE-P195 and LMR-195 is part of our full line of RF components available for same-day shipping. Our UHF male connector operates up to a maximum frequency of 300 MHz.

Our UHF male connector PE44052 datasheet specifications and drawing with dimensions are shown below in this PDF. Pasternack's broad catalog of RF, microwave and millimeter wave connectors allows designers to configure and customize their signal connections however they like. Whether the need is to provide an I/O for a board design, or simply create a custom cable assembly configuration, Pasternack has the right connector for the job. Pasternack can also expertly build your custom cable assemblies for you and ship same-day.

### Electrical Specifications

Description	Minimum	Typical	Maximum	Units
Frequency Range	DC		300	MHz
Operating Voltage (AC)			500	Vrms
Dielectric Withstanding Voltage (AC)			1,500	Vrms

### Mechanical Specifications

<b>Size</b>	
Length	1.26 in [32 mm]
Width/Dia.	0.7 in [17.78 mm]
Weight	0.054 lbs [24.49 g]

Click the following link (or enter part number in "SEARCH" on website) to obtain additional part information including price, inventory and certifications: [UHF Male Connector Clamp/Solder Attachment for RG58, RG55, RG141, RG142, RG223, RG400, RG303, PE-C195, PE-P195, LMR-195 PE44052](#)



UHF Male Connector Clamp/Solder Attachment  
for RG58, RG55, RG141, RG142, RG223, RG400,  
RG303, PE-C195, PE-P195, LMR-195

## RF Connectors Technical Data Sheet

**PE44052**

### Material Specifications

Description	Material	Plating
Contact	Brass	Gold
Insulation	PTFE	
Body	Brass	Nickel 100 µin minimum
Coupling Nut	Brass	Nickel 100 µin minimum

### Mechanical Specification Notes:

When attaching the connector to the cable use a clamp torque value of 26 to 30 in-lbs [2.94 to 3.39 Nm]

### Environmental Specifications

#### Temperature

Operating Range

-55 to +85 deg C

### Compliance Certifications (see [product page](#) for current document)

### Plotted and Other Data

Notes:

UHF Male Connector Clamp/Solder Attachment for RG58, RG55, RG141, RG142, RG223, RG400, RG303, PE-C195, PE-P195, LMR-195 from Pasternack Enterprises has same day shipment for domestic and International orders. Our RF, microwave and millimeter wave products maintain a 99.4% availability and are part of the broadest selection in the industry.

Click the following link (or enter part number in "SEARCH" on website) to obtain additional part information including price, inventory and certifications: [UHF Male Connector Clamp/Solder Attachment for RG58, RG55, RG141, RG142, RG223, RG400, RG303, PE-C195, PE-P195, LMR-195 PE44052](#)

URL: <https://www.pasternack.com/uhf-male-standard-rg58-rg55-rg141-rg142-rg223-rg400-connector-pe44052-p.aspx>

The information contained in this document is accurate to the best of our knowledge and representative of the part described herein. It may be necessary to make modifications to the part and/or the documentation of the part, in order to implement improvements. Pasternack reserves the right to make such changes as required. Unless otherwise stated, all specifications are nominal. Pasternack does not make any representation or warranty regarding the suitability of the part described herein for any particular purpose, and Pasternack does not assume any liability arising out of the use of any part or documentation.

# PE44052 CAD Drawing

UHF Male Connector Clamp/Solder Attachment for RG58, RG55, RG141, RG142, RG223, RG400, RG303, PE-C195, PE-P195, LMR-195

REVISIONS			
REV.	DESCRIPTION	DATE	APPROVED
A	PCR PE44052 20200817	10/20/20	SRAUTJUS

## ASSEMBLY PROCEDURES

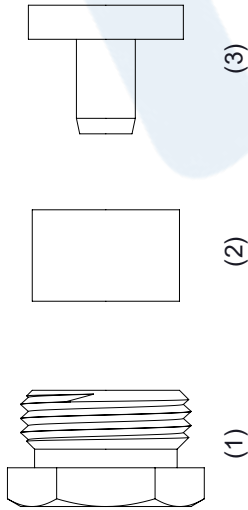

1. SLIDE CLAMP NUT (1) & GASKET (2) OVER CABLE. STRIP CABLE AS SHOWN BELOW.

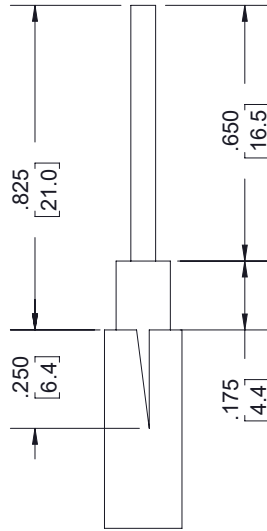

## STRIPPING DIMENSIONS

2. INSERT BRAID CLAMP (3) BETWEEN BRAID & DIELECTRIC. INSERT ASSEMBLY INTO BODY. THEN SOLDER CENTER CONDUCTOR TO CONTACT AND TIGHTEN.

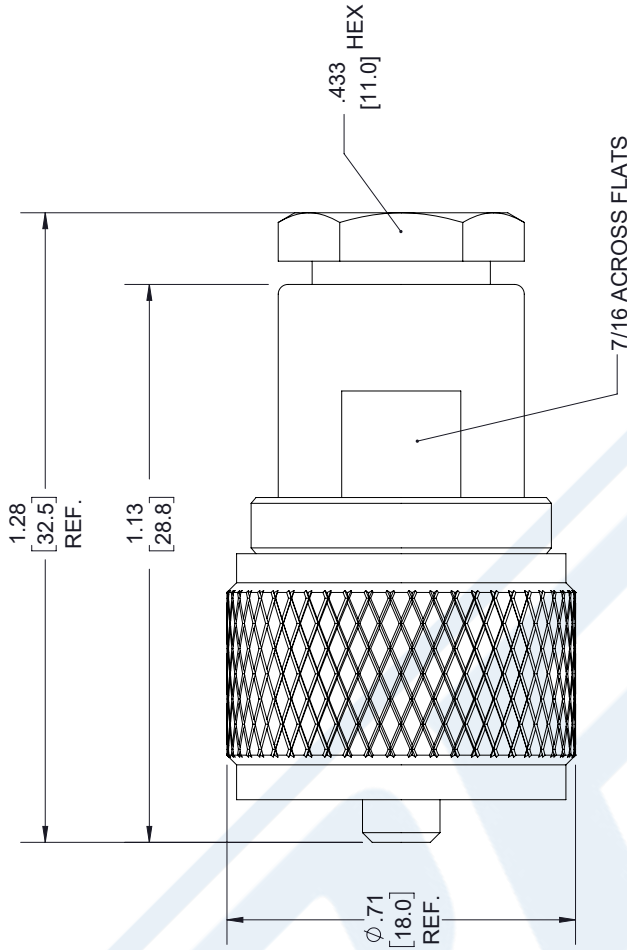

UNLESS OTHERWISE SPECIFIED LEADING DIMENSIONS ARE INCHES DIMENSIONS IN [ ] ARE MILLIMETERS

TOLERANCES:  
 .X = ±.2 [5.08] FRACTIONS ± 1/32  
 .XX = ±.02 [.51] ANGLES ± 1°  
 .XXX = ±.005 [.13]  
 CABLE LENGTH (L) TOLERANCES:  
 L ≤ 12 [305] = +1 [25] / -0  
 12 [305] < L ≤ 60 [1524] = +2 [51] / -0  
 60 [1524] < L ≤ 120 [3048] = +4 [102] / -0  
 120 [3048] < L ≤ 300 [7620] = +6 [152] / -0  
 300 [7620] < L = +5%L / -0  
 ALL DIMENSIONS SHOWN ARE FOR REFERENCE ONLY.



Pasternack Enterprises, Inc.  
 P.O. Box 16759, Irvine, CA 92623.  
 Phone: 1.949.261.1920 | 1.866.727.8376  
 Fax: 1.949.261.7451  
 Website: www.pasternack.com  
 E-mail: sales@pasternack.com

THIRD-ANGLE PROJECTION  
  
 THE INFORMATION AND DESIGN ARE PROPERTY OF PASTERNAK CORPORATION ALL RIGHTS RESERVED.

SHEET 1 OF 1  
 SCALE N/A  
 REV A

SIZE A CAGE CODE 53919 DRAWN BY SLI ITEM NO. PE44052

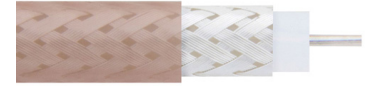

## Flexible RG303 Coax Cable Single Shielded with Tan FEP Jacket

### RF Cables Technical Data Sheet

**RG303/U**

#### Configuration

- Flexible Cable
- 1 Shield(s)

#### Electrical Specifications

Description	Minimum	Typical	Maximum	Units
Frequency Range	DC		3	GHz
Impedance		50		Ohms
Velocity of Propagation		69		%
Dielectric Withstanding Voltage (AC)			5,000	Vrms
Nominal Capacitance		32 [104.99]		pF/ft [pF/m]
Power@ 1GHz			650	Watts

#### Performance by Frequency Band

Description	F1	F2	F3	F4	F5	Units
Frequency	400					MHz
Attenuation, Typ	8.6					dB/100ft
	28.22					dB/100m

#### Mechanical Specifications

Diameter	0.17 in [4.32 mm]
Weight	0.027 lbs/ft [0.04 kg/m]

#### Construction Specifications

Description	Material and Plating	Diameter
Inner Conductor	Copper Clad Steel, Silver, 1 Strand	0.037 in [0.94 mm]
Conductor Type	Solid	
Dielectric	PTFE	0.116 in [2.95 mm]
First Shield	Silver Plated Copper Braid	0.146 in [3.71 mm]

Click the following link (or enter part number in "SEARCH" on website) to obtain additional part information including price, inventory and certifications: [Flexible RG303 Coax Cable Single Shielded with Tan FEP Jacket RG303/U](#)

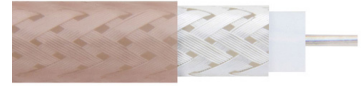

## Flexible RG303 Coax Cable Single Shielded with Tan FEP Jacket

### RF Cables Technical Data Sheet

**RG303/U**

Jacket	FEP, Tan	0.17 in [4.32 mm]
--------	----------	-------------------

#### Environmental Specifications

##### Temperature

Operating Range -55 to +200 deg C

**Compliance Certifications** (see [product page](#) for current document)

#### Plotted and Other Data

Notes:

Flexible RG303 Coax Cable Single Shielded with Tan FEP Jacket from Pasternack Enterprises has same day shipment for domestic and International orders. Our RF, microwave and millimeter wave products maintain a 99.4% availability and are part of the broadest selection in the industry.

Click the following link (or enter part number in "SEARCH" on website) to obtain additional part information including price, inventory and certifications: [Flexible RG303 Coax Cable Single Shielded with Tan FEP Jacket RG303/U](#)

URL: <https://www.pasternack.com/flexible-0.170-rg303-50-ohm-coax-cable-fep-jacket-rg303-u-p.aspx>

The information contained in this document is accurate to the best of our knowledge and representative of the part described herein. It may be necessary to make modifications to the part and/or the documentation of the part, in order to implement improvements. Pasternack reserves the right to make such changes as required. Unless otherwise stated, all specifications are nominal. Pasternack does not make any representation or warranty regarding the suitability of the part described herein for any particular purpose, and Pasternack does not assume any liability arising out of the use of any part or documentation.

# RG303/U CAD Drawing

Flexible RG303 Coax Cable Single Shielded with Tan FEP Jacket

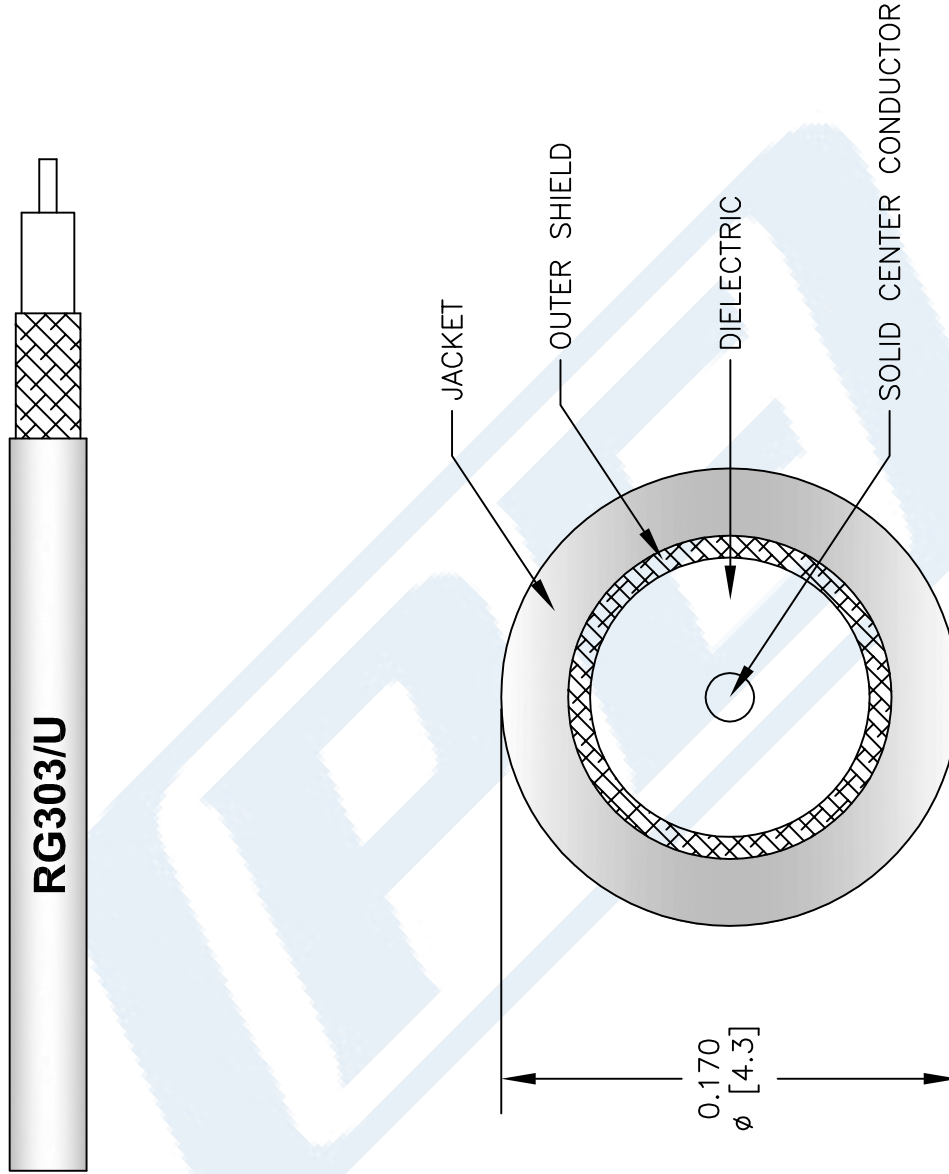

NOTES:  
 1. UNLESS OTHERWISE SPECIFIED ALL DIMENSIONS ARE NOMINAL.  
 2. ALL SPECIFICATIONS ARE SUBJECT TO CHANGE WITHOUT NOTICE AT ANY TIME.  
 3. DIMENSIONS ARE IN INCHES (mm).

DWG TITLE  
**RG303/U**

REV. A FSCM NO. 53919

SCALE N/A

SIZE A

CAD FILE 022908-A

147

**PE PASTERNAK®**  
 Pasternack Enterprises, Inc.  
 P.O. Box 16759 | Irvine | CA | 92623  
**Phone:** (949) 261-1920 | **Fax:** (949) 261-7451  
**Website:** www.pasternack.com | **E-Mail:** sales@pasternack.com