



TNC Female Connector Crimp/Non-Solder Contact Attachment for LMR-240, LMR-240-DB, LMR-240-UF, LMR-240-FR, RG8X, PE-C240

RF Connectors Technical Data Sheet

Times Microwave Systems Connector Specification

Configuration

- TNC Female Connector
- 50 Ohms
- Straight Body Geometry
- Connector Interface Types: LMR-240, LMR-240-DB, LMR-240-UF, LMR-240-FR, RG8X, PE-C240

Features

- Max. Operating Frequency 6 GHz
- Good VSWR of 1.3:1
- Tri-Metal Plated Brass Contact
- 80 μ m minimum contact plating

Applications

- General Purpose Test
- Custom Cable Assemblies

Description

EZ-240-TF-X QMA female coaxial connector has an interface type of QMA female LMR-240, LMR-240-DB, LMR-240-UF, LMR-240-FR, RG8X, and PE-C240 and a 50 Ohms impedance. Pasternack's QMA female connector uses crimp/non-solder contact as an attachment method. Our female QMA coaxial connector provides a maximum frequency of 6 GHz.

The Pasternack QMA female coaxial connector has a PTFE dielectric type and a VSWR of 1.3:1. Pasternack's QMA coaxial connector has a brass body with tri-metal plating. Our EZ-240-TF-X QMA connector uses a tri-metal plated brass contact. Additional RF connector specs and dimensions for this component can be found on its PDF specification datasheet and CAD drawings above.

The radio frequency connector is made from brass material and has a contact life of 500 cycles or more. Our high-quality EZ-240-TF-X features an 80 μ m minimum body plating specification. The Pasternack EZ-240-TF-X QMA connector operates at a temperature range of -55 to 155 deg C.

This Pasternack female QMA connector will ship the same business day as purchased. Our QMA female connector is part of over 40,000 RF, microwave, and millimeter wave components in stock for local, domestic, and international shipment. For further information on similar products, our expert technical support and trained sales team can get you the ideal RF connector as per your requirements.

Electrical Specifications

Description	Minimum	Typical	Maximum	Units
Frequency Range	DC		6	GHz
VSWR			1.3:1	
Insertion Loss			0.24	dB
Impedance		50		Ohms
Insulation Resistance	5,000			MOhms

Electrical Specification Notes:
Insertion Loss is $0.1 \cdot \sqrt{\text{fGHz}}$ dB

Click the following link (or enter part number in "SEARCH" on website) to obtain additional part information including price, inventory and certifications: [TNC Female Connector Crimp/Non-Solder Contact Attachment for LMR-240, LMR-240-DB, LMR-240-UF, LMR-240-FR, RG8X, PE-C240 EZ-240-TF-X](#)



TNC Female Connector Crimp/Non-Solder Contact Attachment for LMR-240, LMR-240-DB, LMR-240-UF, LMR-240-FR, RG8X, PE-C240

RF Connectors Technical Data Sheet



EZ-240-TF-X

Mechanical Specifications

Size

Length	1.07 in [27.18 mm]
Width	0.44 in [11.13 mm]
Height	0.44 in [11.13 mm]
Weight	0.10 lbs [45.36 g]
Mating Cycles	500 Cycles
Cable Retention Force	200 lbs 90.72 kg

Material Specifications

Description	Material	Plating
Contact	Brass	Tri-Metal 80 µin minimum
Insulation	PTFE	
Body	Brass	Tri-Metal 80 µin minimum
Crimp Sleeve	Brass	Tri-Metal 80 µin minimum

Environmental Specifications

Temperature

Operating Range	-55 to +155 deg C
Shock	MIL-STD 202G, Meth.213, Cond I
Vibration	MIL-STD 202G, Meth.204, Cond.B
Thermal Shock	MIL-STD 202G, Meth.107, Cond.B

Compliance Certifications (see [product page](#) for current document)

Plotted and Other Data

Notes:

Click the following link (or enter part number in "SEARCH" on website) to obtain additional part information including price, inventory and certifications: [TNC Female Connector Crimp/Non-Solder Contact Attachment for LMR-240, LMR-240-DB, LMR-240-UF, LMR-240-FR, RG8X, PE-C240 EZ-240-TF-X](#)



TNC Female Connector Crimp/Non-Solder Contact Attachment for LMR-240, LMR-240-DB, LMR-240-UF, LMR-240-FR, RG8X, PE-C240

RF Connectors
Technical Data Sheet

TNC Female Connector Crimp/Non-Solder Contact Attachment for LMR-240, LMR-240-DB, LMR-240-UF, LMR-240-FR, RG8X, PE-C240 from Pasternack Enterprises has same day shipment for domestic and International orders. Our RF, microwave and millimeter wave products maintain a 99.4% availability and are part of the broadest selection in the industry.

Click the following link (or enter part number in "SEARCH" on website) to obtain additional part information including price, inventory and certifications: [TNC Female Connector Crimp/Non-Solder Contact Attachment for LMR-240, LMR-240-DB, LMR-240-UF, LMR-240-FR, RG8X, PE-C240 EZ-240-TF-X](https://www.pasternack.com/tnc-female-lmr-240-lmr-240-db-connector-ez-240-tf-x-p.aspx)

URL: <https://www.pasternack.com/tnc-female-lmr-240-lmr-240-db-connector-ez-240-tf-x-p.aspx>

The information contained in this document is accurate to the best of our knowledge and representative of the part described herein. It may be necessary to make modifications to the part and/or the documentation of the part, in order to implement improvements. Pasternack reserves the right to make such changes as required. Unless otherwise stated, all specifications are nominal. Pasternack does not make any representation or warranty regarding the suitability of the part described herein for any particular purpose, and Pasternack does not assume any liability arising out of the use of any part or documentation.

ZONE	REV	DESCRIPTION	DATE	CHANGED BY	APPROVED
	A	INITIAL RELEASE	5/19/2023	KDANG	AGANWANI

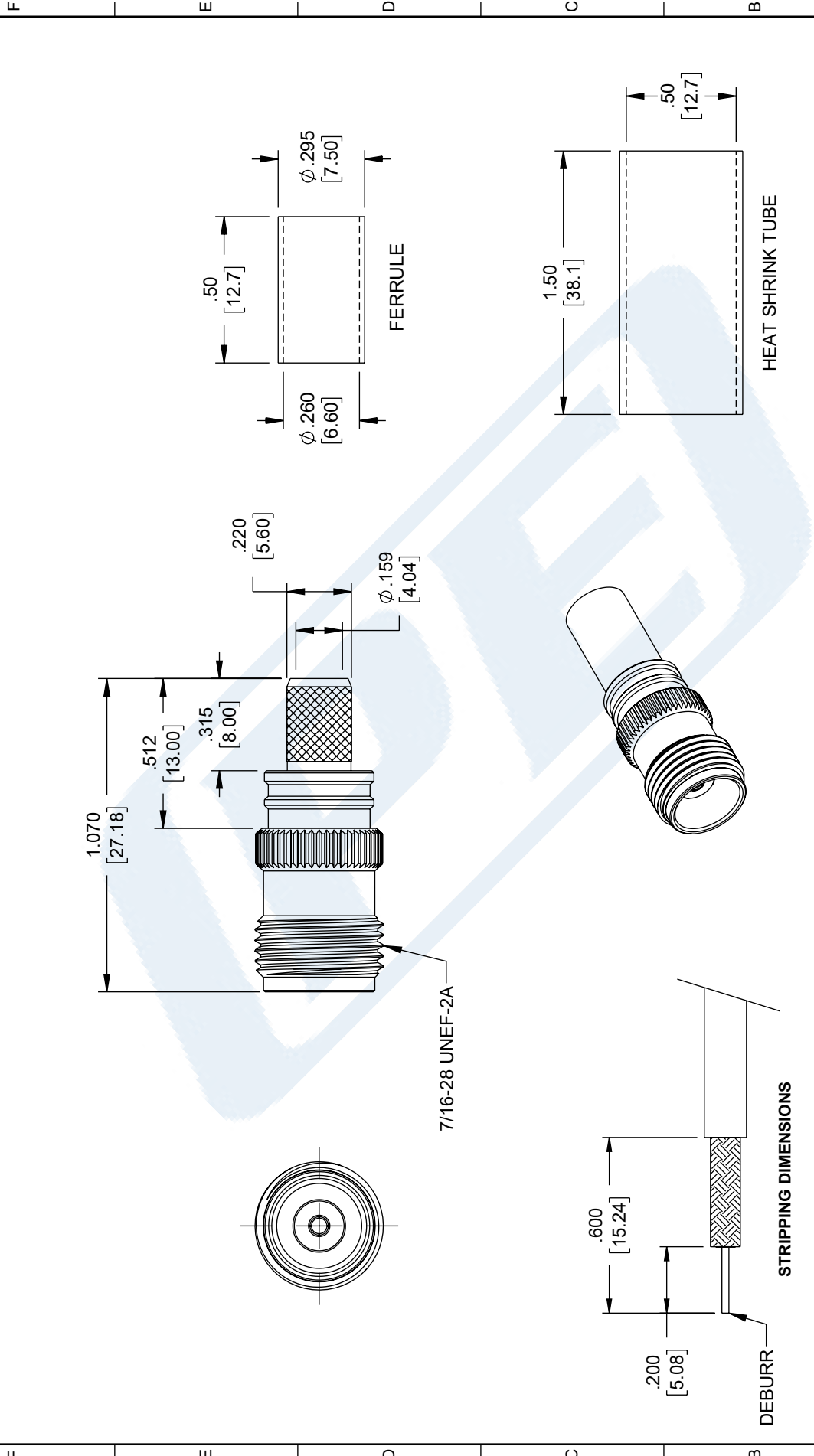

PE PASTERNAK
an INFINITI® brand

Website: www.Pasternack.com
Phone: 1.866.727.8376 | 1.949.261.1920

UNLESS OTHERWISE SPECIFIED
LEADING DIMENSIONS ARE INCHES
DIMENSIONS IN [] ARE MILLIMETERS

TOLERANCES:
 .X = ±.2 [5] FRACTIONS
 .XX = ±.02 [5] ±.1/32
 .XXX = ±.005 [13] ANGLES ± 1°
 CABLE LENGTH TOLERANCES:
 ≤12 [305] = +1 [25] / -0
 >12 [305] ≤ 60 [1524] = +2 [51] / -0
 >60 [1524] ≤ 120 [3048] = +4 [102] / -0
 >120 [3048] ≤ 300 [7620] = +6 [152] / -0
 >300 [7620] = +5% / -0

ALL DIMENSIONS ARE FOR REFERENCE ONLY
AND SUBJECT TO CHANGE WITHOUT NOTICE

INTERPRET ALL DIMENSIONS AND TOLERANCES PER ASME Y14.5
SCALE NONE SHEET 1 OF 1

DESCRIPTION
TNC Female Connector Crimp/Non-Solder Contact Attachment for LMR-240

SIZE	CAGE CODE	DRAWN BY	ITEM NO.
A	53919	KDANG	EZ-240-TF-X

NOTES:

- CABLE ATTACHMENT:
• OUTER: CRIMP.
- CRIMP SIZE REQUIRED:
• FERRULE: .255 [6.48] HEX. CRIMP TOOL.

STRIPPING DIMENSIONS

DEBURR

7/16-28 UNEF-2A

HEAT SHRINK TUBE

FERRULE

THE INFORMATION CONTAINED IN THIS DRAWING IS THE SOLE PROPERTY OF INFINITE ELECTRONICS, INC. ANY REPRODUCTION IN PART OR WHOLE WITHOUT THE WRITTEN PERMISSION OF INFINITE ELECTRONICS, INC. IS PROHIBITED. THESE COMMODITIES, TECHNOLOGY OR SOFTWARE WERE EXPORTED FROM THE UNITED STATES IN ACCORDANCE WITH THE EXPORT ADMINISTRATION REGULATIONS. DIVERSION CONTRARY TO U.S. LAW PROHIBITED.

RP-TNC Jack Connector Crimp/Non-Solder Contact Attachment for LMR-240, LMR-240-DB, LMR-240-UF, LMR-240-FR, RG8X, PE-C240



RF Connectors Technical Data Sheet



EZ-240-TF-RP-X

Times Microwave Systems Connector Specification

Configuration

- TNC Jack Reverse Polarity Connector
- 50 Ohms
- Straight Body Geometry
- Connector Interface Types: LMR-240, LMR-240-DB, LMR-240-UF, LMR-240-FR, RG8X, PE-C240

Features

- Max. Operating Frequency 6 GHz
- Good VSWR of 1.3:1
- Tri-Metal Plated Brass Contact
- 80 μ m minimum contact plating
- Reverse Polarity

Applications

- General Purpose Test
- Custom Cable Assemblies

Description

EZ-240-TF-RP-X RP TNC jack coaxial connector has an interface type of TNC jack LMR-240, LMR-240-DB, LMR-240-UF, LMR-240-FR, RG8X, and PE-C240 and a 50 Ohms impedance. Pasternack's TNC jack connector uses crimp/non-solder contact as an attachment method. Our jack TNC coaxial connector provides a maximum frequency of 6 GHz.

The Pasternack TNC jack coaxial connector has a PTFE dielectric type and a VSWR of 1.3:1. Pasternack's TNC coaxial connector has a brass body with tri-metal plating. Our EZ-240-TF-RP-X TNC connector uses a tri-metal plated brass contact. Additional RF connector specs and dimensions for this component can be found on its PDF specification datasheet and CAD drawings above.

The radio frequency connector is made from brass material and has a contact life of 500 cycles or more. Our high-quality EZ-240-TF-RP-X features an 80 μ m minimum body plating specification. The Pasternack EZ-240-TF-RP-X TNC connector operates at a temperature range of -40 to 125 deg C.

This Pasternack reverse polarity jack TNC connector will ship the same business day as purchased. Our TNC jack connector is part of over 40,000 RF, microwave, and millimeter wave components in stock for local, domestic, and international shipment. For further information on similar products, our expert technical support and trained sales team can get you the ideal RF connector as per your requirements.

Electrical Specifications

Description	Minimum	Typical	Maximum	Units
Frequency Range	DC		6	GHz
VSWR			1.3:1	
Insertion Loss			0.24	dB
Impedance		50		Ohms
Dielectric Withstanding Voltage (DC)			1,500	Vdc
Insulation Resistance	5,000			MOhms

Click the following link (or enter part number in "SEARCH" on website) to obtain additional part information including price, inventory and certifications: [RP-TNC Jack Connector Crimp/Non-Solder Contact Attachment for LMR-240, LMR-240-DB, LMR-240-UF, LMR-240-FR, RG8X, PE-C240 EZ-240-TF-RP-X](#)



RP-TNC Jack Connector Crimp/Non-Solder Contact Attachment for LMR-240, LMR-240-DB, LMR-240-UF, LMR-240-FR, RG8X, PE-C240

RF Connectors Technical Data Sheet

Electrical Specification Notes:
Insertion Loss is $0.1 \cdot \sqrt{f(\text{GHz})}$ dB

Mechanical Specifications

Size

Length	1.20 in [30.48 mm]
Width	0.43 in [10.92 mm]
Height	0.43 in [10.92 mm]
Weight	0.10 lbs [45.36 g]
Mating Cycles	500 Cycles
Cable Retention Force	250 lbs 113.4 kg

Material Specifications

Description	Material	Plating
Contact	Brass	Tri-Metal 80 µin minimum
Insulation	PTFE	
Body	Brass	Tri-Metal 80 µin minimum
Crimp Sleeve	Brass	Tri-Metal 80 µin minimum

Environmental Specifications

Temperature

Operating Range	-40 to +125 deg C
Shock	MIL-STD 202G, Meth.213, Cond.G
Vibration	MIL-STD 202G, Meth.204, Cond.B
Thermal Shock	MIL-STD 202G, Meth.107, Cond.B

Compliance Certifications (see [product page](#) for current document)

Plotted and Other Data

Notes:

Click the following link (or enter part number in "SEARCH" on website) to obtain additional part information including price, inventory and certifications: [RP-TNC Jack Connector Crimp/Non-Solder Contact Attachment for LMR-240, LMR-240-DB, LMR-240-UF, LMR-240-FR, RG8X, PE-C240 EZ-240-TF-RP-X](#)



RP-TNC Jack Connector Crimp/Non-Solder Contact Attachment for LMR-240, LMR-240-DB, LMR-240-UF, LMR-240-FR, RG8X, PE-C240

RF Connectors Technical Data Sheet

RP-TNC Jack Connector Crimp/Non-Solder Contact Attachment for LMR-240, LMR-240-DB, LMR-240-UF, LMR-240-FR, RG8X, PE-C240 from Pasternack Enterprises has same day shipment for domestic and International orders. Our RF, microwave and millimeter wave products maintain a 99.4% availability and are part of the broadest selection in the industry.

Click the following link (or enter part number in "SEARCH" on website) to obtain additional part information including price, inventory and certifications: [RP-TNC Jack Connector Crimp/Non-Solder Contact Attachment for LMR-240, LMR-240-DB, LMR-240-UF, LMR-240-FR, RG8X, PE-C240 EZ-240-TF-RP-X](#)

URL: <https://www.pasternack.com/tnc-jack-reverse-polarity-lmr-240-connector-ez-240-tf-rp-x.p.aspx>

The information contained in this document is accurate to the best of our knowledge and representative of the part described herein. It may be necessary to make modifications to the part and/or the documentation of the part, in order to implement improvements. Pasternack reserves the right to make such changes as required. Unless otherwise stated, all specifications are nominal. Pasternack does not make any representation or warranty regarding the suitability of the part described herein for any particular purpose, and Pasternack does not assume any liability arising out of the use of any part or documentation.

EZ-240-TF-RP-X CAD Drawing
 RP-TNC Jack Connector Crimp/Non-Solder Contact Attachment for LMR-240, LMR-240-DB, LMR-240-UF, LMR-240-FR, RG8X, PE-C240

ZONE	REV	DESCRIPTION	DATE	CHANGED BY	APPROVED
	A	INITIAL RELEASE	5/19/2023	KDANG	AGANWANI

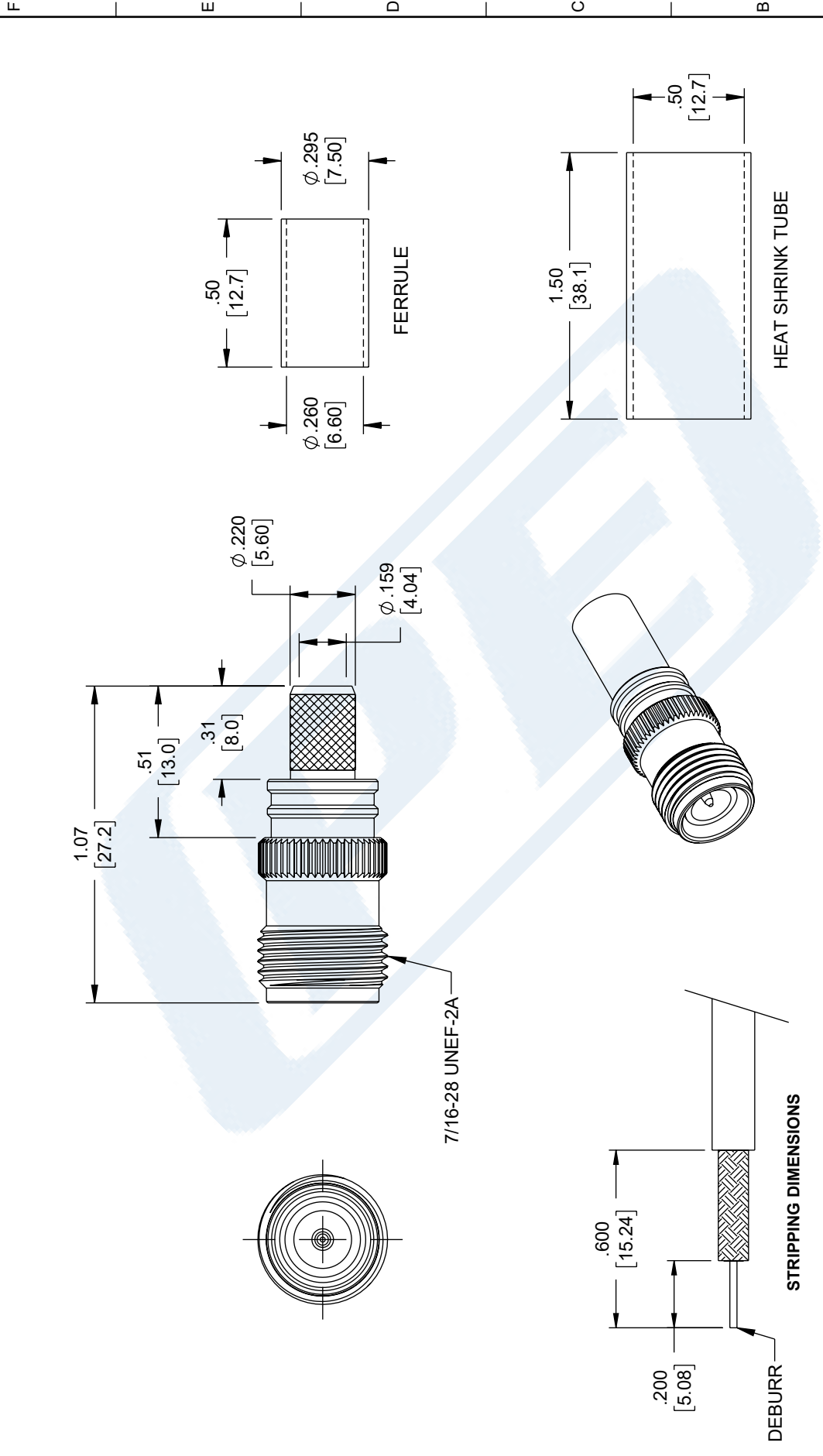

PASTERNAK
 an INFINITI® brand

Website: www.Pasternack.com
 Phone: 1.866.727.8376 | 1.949.261.1920

INTERPRET ALL DIMENSIONS AND TOLERANCES PER ASME Y14.5
 SCALE: NONE
 SHEET: 1 OF 1

DESCRIPTION:
 RP-TNC Jack Connector Crimp/Non-Solder Contact Attachment for LMR-240

SIZE	A	CAGE CODE	53919	DRAWN BY	KDANG	ITEM NO.	EZ-240-TF-RP-X
REV	A						

UNLESS OTHERWISE SPECIFIED LEADING DIMENSIONS ARE INCHES DIMENSIONS IN [] ARE MILLIMETERS
 TOLERANCES:
 .X = ±.2 [5] FRACTIONS ±.1/32
 .XX = ±.02 [5] ±.1/32
 .XXX = ±.005 [13] ANGLES ± 1°
 CABLE LENGTH TOLERANCES:
 ≤12 [305] = +1 [25] / -0
 >12 [305] ≤ 60 [1524] = +2 [51] / -0
 >60 [1524] ≤ 120 [3048] = +4 [102] / -0
 >120 [3048] ≤ 300 [7620] = +6 [152] / -0
 >300 [7620] = +5% / -0

ALL DIMENSIONS ARE FOR REFERENCE ONLY AND SUBJECT TO CHANGE WITHOUT NOTICE

NOTES:
 1. CABLE ATTACHMENT:
 • OUTER: CRIMP.
 2. CRIMP SIZE REQUIRED:
 • FERRULE: .255 [6.48] HEX. CRIMP TOOL.

THE INFORMATION CONTAINED IN THIS DRAWING IS THE SOLE PROPERTY OF INFINITE ELECTRONICS, INC. ANY REPRODUCTION IN PART OR WHOLE WITHOUT THE WRITTEN PERMISSION OF INFINITE ELECTRONICS, INC. IS PROHIBITED. THESE COMMODITIES, TECHNOLOGY OR SOFTWARE WERE EXPORTED FROM THE UNITED STATES IN ACCORDANCE WITH THE EXPORT ADMINISTRATION REGULATIONS. DIVERSION CONTRARY TO U.S. LAW PROHIBITED.



LMR-240-FR Fire Rated version of the 240 series Low Loss Coax

RF Cables Technical Data Sheet

LMR-240-FR

Times Microwave Systems Coax Cable Specification

Configuration

- Low Loss, Outdoor Flexible Cable
- 2 Shield(s)

Features

- CMR Riser Rated Coax
- Non-Halogen, Low Smoke FRPE Jacket
- Max Operating Frequency of 5.8 GHz
- Phase Velocity 83% VoP
- Max Operating Temperature +85°C
- Min Install Bend Radius of 0.75 inches

Applications

- In-Building Riser Runs
- Short Antenna Installs
- RF Test Systems
- General Purpose RF Interconnect
- Laboratory Applications

Description

LMR-240-FR Fire Rated version of the 240 series Low Loss Coax from Times Microwave is part of the large product offering by Pasternack of radio frequency coaxial cable types specifically stocked to be ready for same-day shipment. Pasternack LMR-240-FR coax cable is manufactured in a flexible design and has a 50 Ohm impedance. This low loss and CMR riser rated 50 Ohm coax cable LMR-240-FR is constructed with a 0.240 inch diameter and Black FRPE jacket.

LMR-240-FR flexible 50 Ohm coax cable with FRPE jacket is rated for a 5.8 GHz maximum operating frequency. This 50 Ohm 0.240 inch diameter and low loss fire rated coax cable is built with an aluminum double shield count and RF shielding of 90 dB. Times Microwave LMR-240-FR FRPE coax is constructed with Foam PE dielectric and a maximum operating temperature of 85 degrees C. Pasternack's offering of LMR-240-FR coax cable provides specs for this wire on its RF coax cable LMR-240-FR datasheet.

LMR-240-FR cable is part of more than one million RF, microwave parts in stock at Pasternack. This Times Microwave low loss flexible LMR-240-FR coax cable is ready to buy and can be shipped worldwide. Pasternack also maintains a wide selection of other radio frequency coaxial cable types that ship same-day from our warehouse as with the rest of our other RF/microwave components.

* LMR™ is a trademark of Times Microwave Systems.

Electrical Specifications

Description	Minimum	Typical	Maximum	Units
Frequency Range	DC		5.8	GHz
Impedance		50		Ohms
Velocity of Propagation		83		%
Time Delay		1.21 3.97		ns/ft ns/m
Shielding Effectiveness	90			dB
Dielectric Withstanding Voltage (DC)			1,500	Vdc

Click the following link (or enter part number in "SEARCH" on website) to obtain additional part information including price, inventory and certifications: [LMR-240-FR Fire Rated version of the 240 series Low Loss Coax LMR-240-FR](#)



LMR-240-FR Fire Rated version of the 240 series Low Loss Coax

RF Cables Technical Data Sheet



LMR-240-FR

Jacket Spark	5,000	Vrms
Inner Conductor DC Resistance	3.2	Ohms/1000ft
Outer Conductor DC Resistance	3.89	Ohms/1000ft
Nominal Capacitance	24.2 [79.4]	pF/ft [pF/m]
Nominal Inductance	0.06 [0.2]	uH/ft [uH/m]
Input Power (Peak)	5.6	kWatts

Performance by Frequency Band

Description	F1	F2	F3	F4	F5	Units
Frequency	50	150	220	450	900	MHz
Attenuation, Typ	1.7	3	3.7	5.3	7.6	dB/100ft
	5.58	9.84	12.14	17.39	24.93	dB/100m
Input Power (CW), Max	1,150	660	540	380	260	Watts

Description	F6	F7	F8	F9	F10	Units
Frequency	1.5	1.8	2	2.5	5.8	GHz
Attenuation, Typ	9.9	10.9	11.5	12.9	20.4	dB/100ft
	32.48	35.76	37.73	42.32	66.93	dB/100m
Input Power (CW), Max	200	180	170	150	100	Watts

Mechanical Specifications

Diameter	0.24 in 6.1 mm
Min. Bend Radius (Installation)	0.75 in [19.05 mm]
Min. Bend Radius (Repeated)	2.5 in [63.5 mm]
Bending Moment	0.25 lbs-ft [0.34 N-m]
Tensile Strength	80 lbs [36.29 kg]
Flat Plate Crush	20 lbs/in [0.36 Kg/mm]

Construction Specifications

Description	Material and Plating	Diameter
Inner Conductor	Copper, 1 Strand	0.056 in [1.42 mm]
Conductor Type	Solid	

Click the following link (or enter part number in "SEARCH" on website) to obtain additional part information including price, inventory and certifications: [LMR-240-FR Fire Rated version of the 240 series Low Loss Coax LMR-240-FR](#)



LMR-240-FR Fire Rated version of the 240 series Low Loss Coax

RF Cables
Technical Data Sheet



LMR-240-FR

Dielectric	Foam PE	0.15 in [3.81 mm]
First Shield	Aluminum Tape	[]
Second Shield	Tinned Copper	[]
Jacket	FRPE, Black	0.24 in [6.1 mm]

Environmental Specifications

Temperature

Operating Range	-40 to +85 deg C
Installation Range	-40 to +85 deg C
Storage Range	-70 to +85 deg C

Compliance Certifications (see [product page](#) for current document)

Plotted and Other Data

Notes:

LMR-240-FR Fire Rated version of the 240 series Low Loss Coax from Pasternack Enterprises has same day shipment for domestic and International orders. Our RF, microwave and millimeter wave products maintain a 99.4% availability and are part of the broadest selection in the industry.

Click the following link (or enter part number in "SEARCH" on website) to obtain additional part information including price, inventory and certifications: [LMR-240-FR Fire Rated version of the 240 series Low Loss Coax LMR-240-FR](#)

URL: <https://www.pasternack.com/low-loss-flexible-lmr-240-fr-frpe-jacket-aluminum-tape-over-tinned-copper-outer-conductor-double-shielded-lmr-240-fr-p.aspx>

The information contained in this document is accurate to the best of our knowledge and representative of the part described herein. It may be necessary to make modifications to the part and/or the documentation of the part, in order to implement improvements. Pasternack reserves the right to make such changes as required. Unless otherwise stated, all specifications are nominal. Pasternack does not make any representation or warranty regarding the suitability of the part described herein for any particular purpose, and Pasternack does not assume any liability arising out of the use of any part or documentation.

REVISIONS		
REV.	DESCRIPTION	DATE
A	INITIAL RELEASE	06-04-2021
		APPROVED
		SELLIS

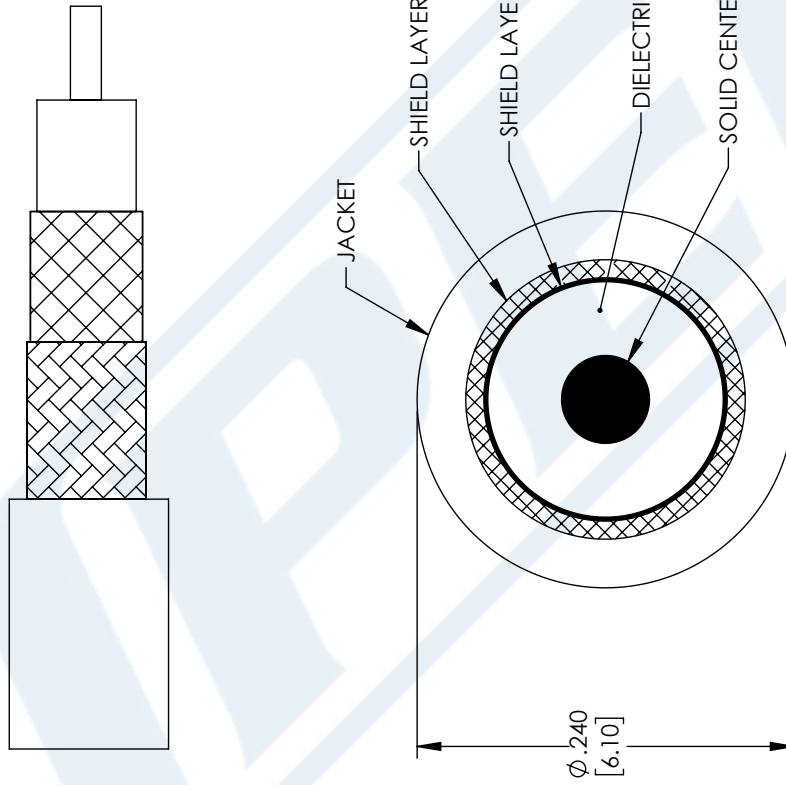

UNLESS OTHERWISE SPECIFIED
 LEADING DIMENSIONS ARE INCHES
 DIMENSIONS IN [] ARE MILLIMETERS

TOLERANCES:
 .X = ±.2 [.008] FRACTIONS ± 1/32
 .XX = ±.02 [.51] ANGLES ± 1°
 .XXX = ±.005 [.13]

CABLE LENGTH (L) TOLERANCES:
 L ≤ 12 [305] = +1 [25] / -0
 12 [305] < L ≤ 60 [1524] = +2 [51] / -0
 60 [1524] < L ≤ 120 [3048] = +4 [102] / -0
 120 [3048] < L ≤ 300 [7620] = +6 [152] / -0
 300 [7620] < L = +5% / -0

ALL DIMENSIONS SHOWN
 ARE FOR REFERENCE ONLY.

PE PASTERNAK
 an INFINITI brand

Pasternack Enterprises, Inc.
 P. O. Box 16759, Irvine, CA 92623.
 Phone: 1.949.261.1920 | 1.866.727.8376
 Fax: 1.949.261.7451
 Website: www.pasternack.com
 E-mail: sales@pasternack.com

ITEM NO. LMR-240-FR
 DRAWN BY MVEERAPPAN
 CAGE CODE 53919

THIRD-ANGLE PROJECTION

THE INFORMATION AND
 DESIGN IN THIS DOCUMENT
 IS THE PROPERTY OF
 PASTERNAK CORPORATION
 ALL RIGHTS RESERVED.

SHEET 1 OF 1
 SCALE N/A
 REV A