



# SMA Female Bulkhead Mount Connector Crimp/ Solder Attachment for RG58, RG303, LMR-195

## RF Connectors Technical Data Sheet

**PE45197**

### Configuration

- SMA Female Connector
- 50 Ohms
- Straight Body Geometry
- Connector Interface Types: RG58, RG303, LMR-195
- Bulkhead

### Features

- Max. Operating Frequency 12 GHz
- Good VSWR of 1.3:1
- Gold over Nickel over Copper Plated Phosphor Bronze Contact

### Applications

- General Purpose Test
- Rack and Panel Mount Applications
- Custom Cable Assemblies

### Description

Pasternack's PE45197 , SMA, Standard, Connector is part of our full line of RF components available for same-day shipping. Our SMA female connector operates up to a maximum frequency of 12 GHz and offers good VSWR of 1.3:1. This SMA bulkhead connector allows designers to create external connections on their product enclosures, and can be used in a variety of other rack mount and panel mount applications.

Our SMA female bulkhead connector PE45197 datasheet specifications and drawing with dimensions are shown below in this PDF. Pasternack's broad catalog of RF, microwave and millimeter wave connectors allows designers to configure and customize their signal connections however they like. Whether the need is to provide an I/O for a board design, or simply create a custom cable assembly configuration, Pasternack has the right connector for the job. Pasternack can also expertly build your custom cable assemblies for you and ship same-day.

### Electrical Specifications

Description	Minimum	Typical	Maximum	Units
Frequency Range	DC		12	GHz
VSWR			1.3:1	
Impedance		50		Ohms

### Mechanical Specifications

Size	
Length	0.74 in [18.80 mm]
Width	0.32 in [8.00 mm]
Height	0.00 in [0.00 mm]
Weight	0.02 lbs [7.26 g]
Mating Torque	8 to 10 in-lbs [0.90 to 1.13 Nm]

Click the following link (or enter part number in "SEARCH" on website) to obtain additional part information including price, inventory and certifications: [SMA Female Bulkhead Mount Connector Crimp/Solder Attachment for RG58, RG303, LMR-195 PE45197](#)



# SMA Female Bulkhead Mount Connector Crimp/ Solder Attachment for RG58, RG303, LMR-195

## RF Connectors Technical Data Sheet

**PE45197**

### Material Specifications

Description	Material	Plating
Contact	Phosphor Bronze	Gold over Nickel over Copper
Insulation	PTFE	
Body	Brass	Gold over Nickel over Copper
Coupling Nut	Brass	Gold over Nickel over Copper
Crimp Sleeve	Brass	
Washer		Gold over Nickel over Copper

### Environmental Specifications

**Compliance Certifications** (see [product page](#) for current document)

### Plotted and Other Data

Notes:

SMA Female Bulkhead Mount Connector Crimp/Solder Attachment for RG58, RG303, LMR-195 from Pasternack Enterprises has same day shipment for domestic and International orders. Our RF, microwave and millimeter wave products maintain a 99.4% availability and are part of the broadest selection in the industry.

Click the following link (or enter part number in "SEARCH" on website) to obtain additional part information including price, inventory and certifications: [SMA Female Bulkhead Mount Connector Crimp/Solder Attachment for RG58, RG303, LMR-195 PE45197](#)

URL: <https://www.pasternack.com/sma-female-rg58-rg303-lmr-195-connector-pe45197-p.aspx>

The information contained in this document is accurate to the best of our knowledge and representative of the part described herein. It may be necessary to make modifications to the part and/or the documentation of the part, in order to implement improvements. Pasternack reserves the right to make such changes as required. Unless otherwise stated, all specifications are nominal. Pasternack does not make any representation or warranty regarding the suitability of the part described herein for any particular purpose, and Pasternack does not assume any liability arising out of the use of any part or documentation.

# PE45197 CAD Drawing

SMA Female Bulkhead Mount Connector Crimp/Solder Attachment for RG58, RG303, LMR-195

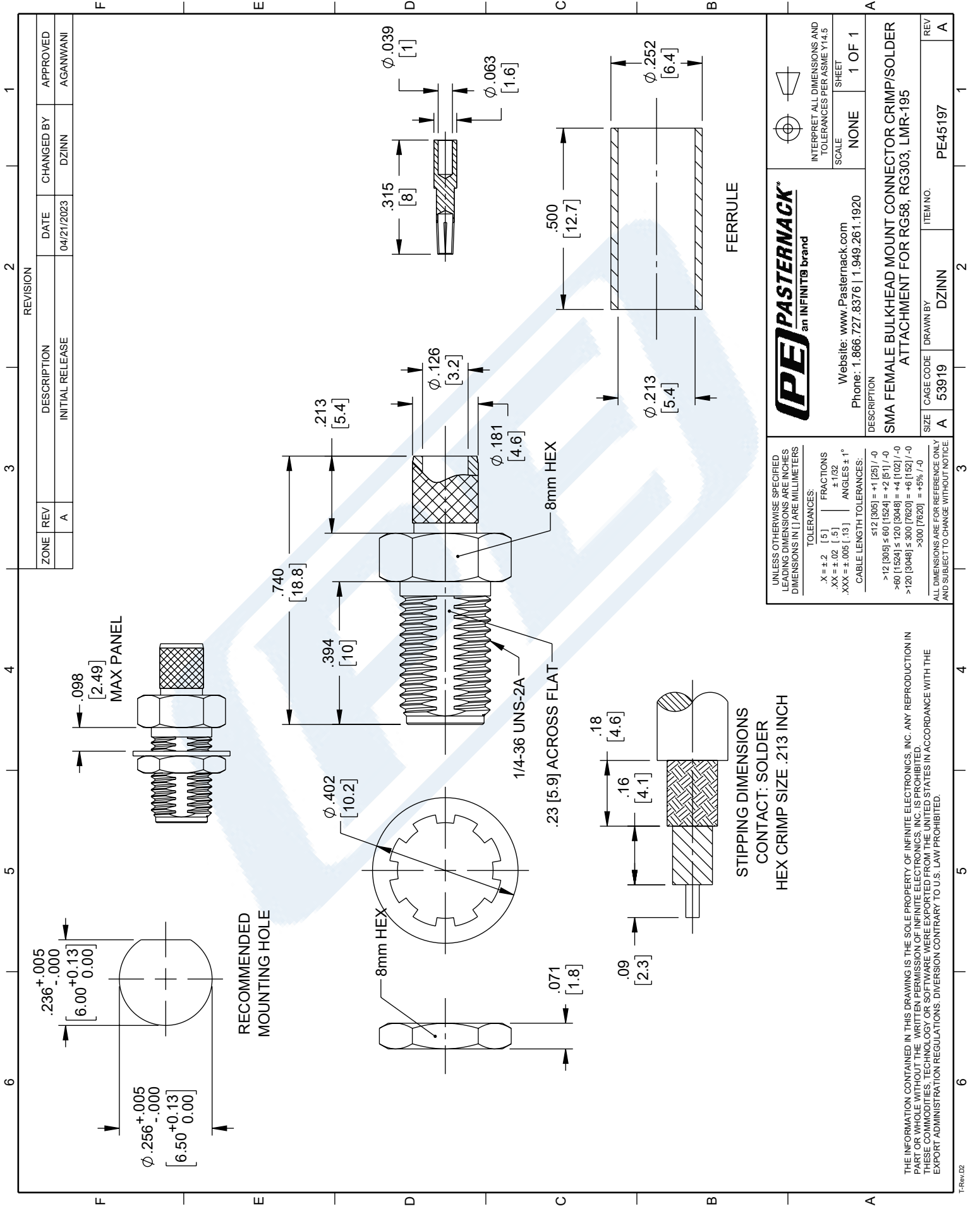



# SMA Female Bulkhead Mount Connector Crimp/ Solder Attachment for RG58, RG303, LMR-195

## RF Connectors Technical Data Sheet

**PE45197**

### Configuration

- SMA Female Connector
- 50 Ohms
- Straight Body Geometry
- Connector Interface Types: RG58, RG303, LMR-195
- Bulkhead

### Features

- Max. Operating Frequency 12 GHz
- Good VSWR of 1.3:1
- Gold over Nickel over Copper Plated Phosphor Bronze Contact

### Applications

- General Purpose Test
- Rack and Panel Mount Applications
- Custom Cable Assemblies

### Description

Pasternack's PE45197 , SMA, Standard, Connector is part of our full line of RF components available for same-day shipping. Our SMA female connector operates up to a maximum frequency of 12 GHz and offers good VSWR of 1.3:1. This SMA bulkhead connector allows designers to create external connections on their product enclosures, and can be used in a variety of other rack mount and panel mount applications.

Our SMA female bulkhead connector PE45197 datasheet specifications and drawing with dimensions are shown below in this PDF. Pasternack's broad catalog of RF, microwave and millimeter wave connectors allows designers to configure and customize their signal connections however they like. Whether the need is to provide an I/O for a board design, or simply create a custom cable assembly configuration, Pasternack has the right connector for the job. Pasternack can also expertly build your custom cable assemblies for you and ship same-day.

### Electrical Specifications

Description	Minimum	Typical	Maximum	Units
Frequency Range	DC		12	GHz
VSWR			1.3:1	
Impedance		50		Ohms

### Mechanical Specifications

Size	
Length	0.74 in [18.80 mm]
Width	0.32 in [8.00 mm]
Height	0.00 in [0.00 mm]
Weight	0.02 lbs [7.26 g]
Mating Torque	8 to 10 in-lbs [0.90 to 1.13 Nm]

Click the following link (or enter part number in "SEARCH" on website) to obtain additional part information including price, inventory and certifications: [SMA Female Bulkhead Mount Connector Crimp/Solder Attachment for RG58, RG303, LMR-195 PE45197](#)



SMA Female Bulkhead Mount Connector Crimp/  
Solder Attachment for RG58, RG303, LMR-195

**RF Connectors**  
**Technical Data Sheet**

**PE45197**

**Material Specifications**

Description	Material	Plating
Contact	Phosphor Bronze	Gold over Nickel over Copper
Insulation	PTFE	
Body	Brass	Gold over Nickel over Copper
Coupling Nut	Brass	Gold over Nickel over Copper
Crimp Sleeve	Brass	
Washer		Gold over Nickel over Copper

**Environmental Specifications**

**Compliance Certifications** (see [product page](#) for current document)

**Plotted and Other Data**

Notes:

SMA Female Bulkhead Mount Connector Crimp/Solder Attachment for RG58, RG303, LMR-195 from Pasternack Enterprises has same day shipment for domestic and International orders. Our RF, microwave and millimeter wave products maintain a 99.4% availability and are part of the broadest selection in the industry.

Click the following link (or enter part number in "SEARCH" on website) to obtain additional part information including price, inventory and certifications: [SMA Female Bulkhead Mount Connector Crimp/Solder Attachment for RG58, RG303, LMR-195 PE45197](#)

URL: <https://www.pasternack.com/sma-female-rg58-rg303-lmr-195-connector-pe45197-p.aspx>

The information contained in this document is accurate to the best of our knowledge and representative of the part described herein. It may be necessary to make modifications to the part and/or the documentation of the part, in order to implement improvements. Pasternack reserves the right to make such changes as required. Unless otherwise stated, all specifications are nominal. Pasternack does not make any representation or warranty regarding the suitability of the part described herein for any particular purpose, and Pasternack does not assume any liability arising out of the use of any part or documentation.

# PE45197 CAD Drawing

SMA Female Bulkhead Mount Connector Crimp/Solder Attachment for RG58, RG303, LMR-195

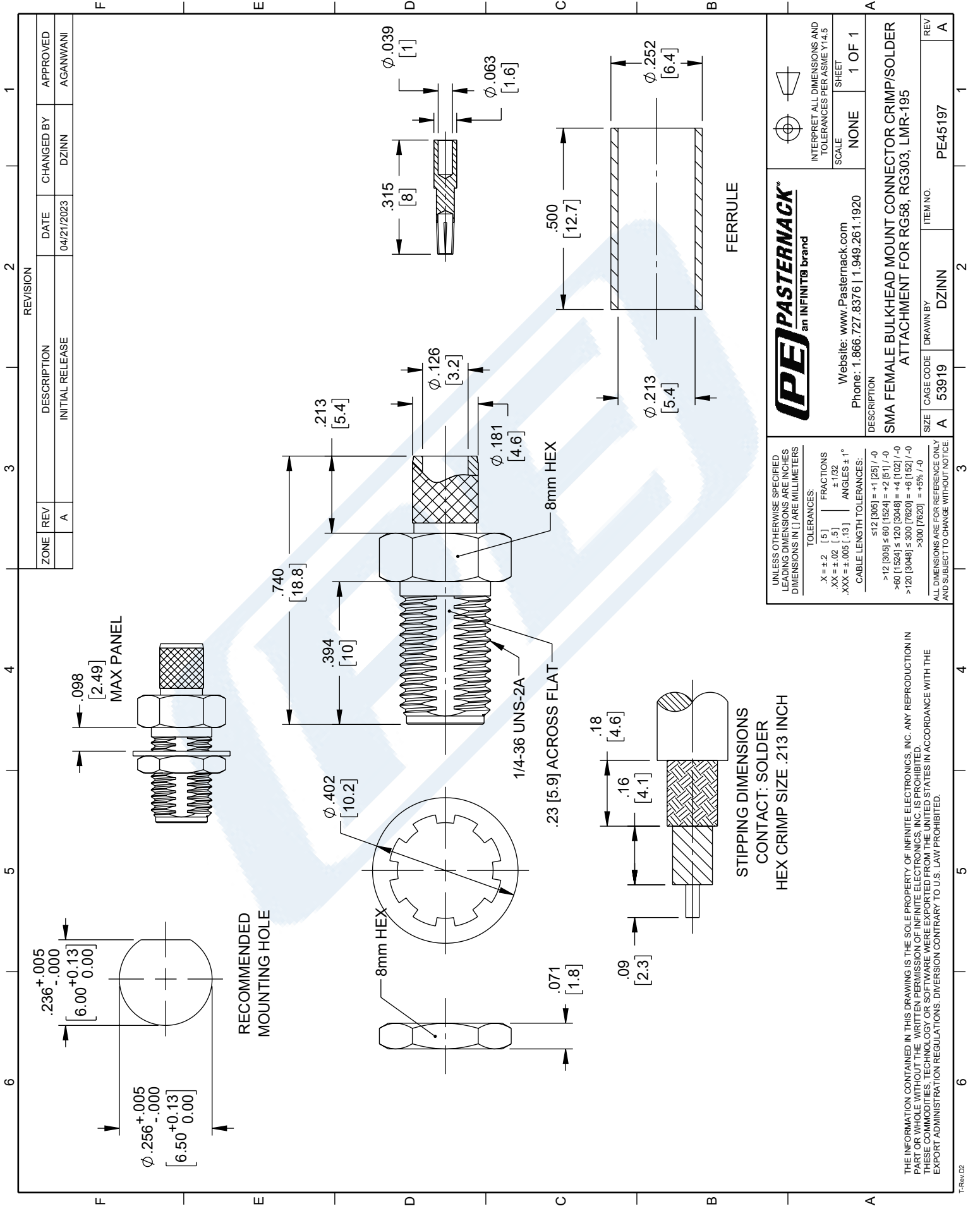

INTERPRET ALL DIMENSIONS AND TOLERANCES PER ASME Y14.5  
SCALE NONE  
SHEET 1 OF 1

Website: [www.Pasternack.com](http://www.Pasternack.com)  
Phone: 1.866.727.8376 | 1.949.261.1920

DESCRIPTION  
**SMA FEMALE BULKHEAD MOUNT CONNECTOR CRIMP/SOLDER ATTACHMENT FOR RG58, RG303, LMR-195**

SIZE A CAGE CODE 53919 DRAWN BY DZINN ITEM NO. PE45197 REV A

UNLESS OTHERWISE SPECIFIED LEADING DIMENSIONS ARE IN INCHES DIMENSIONS IN [ ] ARE MILLIMETERS

TOLERANCES:

X = ±.2 [5] FRACTIONS  
.XX = ±.02 [.5] ±.1/32  
.XXX = ±.005 [.13] ANGLES ± 1°

CABLE LENGTH TOLERANCES:

≤12 [305] = +1 [25] / -0  
>12 [305] ≤ 60 [1524] = +2 [51] / -0  
>60 [1524] ≤ 120 [3048] = +4 [102] / -0  
>120 [3048] ≤ 300 [7620] = +6 [152] / -0  
>300 [7620] = +5% / -0

ALL DIMENSIONS ARE FOR REFERENCE ONLY AND SUBJECT TO CHANGE WITHOUT NOTICE

THE INFORMATION CONTAINED IN THIS DRAWING IS THE SOLE PROPERTY OF INFINITE ELECTRONICS, INC. ANY REPRODUCTION IN PART OR WHOLE WITHOUT THE WRITTEN PERMISSION OF INFINITE ELECTRONICS, INC. IS PROHIBITED. THESE COMMODITIES, TECHNOLOGY OR SOFTWARE WERE EXPORTED FROM THE UNITED STATES IN ACCORDANCE WITH THE EXPORT ADMINISTRATION REGULATIONS. DIVERSION CONTRARY TO U.S. LAW PROHIBITED.

## 086 Semi-rigid Coax Cable with Copper Outer Conductor

### TECHNICAL DATA SHEET

RG405/U

#### 086 Semi-rigid Coax Cable with Copper Outer Conductor

##### Configuration

Inner Conductor Material and Plating	Copper Clad Steel, Silver
Dielectric Type	PTFE
Shield Materials	Copper
Jacket Material and Color	Tan

##### Electrical Specifications

Impedance, Ohms	50
Maximum Operating Frequency, GHz	40
Dielectric Withstanding Voltage, Vrms	5,000

##### Electrical Specifications by Frequency

###### Frequency 1

Frequency, MHz	1000
Attenuation, dB/100ft [dB/100m]	22 [72.18]
Power Handling, Watts	130

###### Frequency 2

Frequency, GHz	10
Attenuation, dB/100ft [dB/100m]	80 [262.47]
Power Handling, Watts	35

###### Frequency 3

Frequency, GHz	20
Attenuation, dB/100ft [dB/100m]	120 [393.7]
Power Handling, Watts	20

##### Mechanical Specifications

###### Temperature

Operating Range, deg C	-55 to +125
------------------------	-------------

###### Inner Conductor

Number of Strands	1
Material	Copper Clad Steel
Plating	Silver
Diameter, in [mm]	0.02 [0.51]

###### Dielectric:

Type	PTFE
Diameter, in [mm]	0.066 [1.68]

Click the following link (or enter part number in "SEARCH" on website) to obtain additional part information including price, inventory and certifications: [086 Semi-rigid Coax Cable with Copper Outer Conductor RG405/U](#)

The information contained in this document is accurate to the best of our knowledge and representative of the part described herein. It may be necessary to make modifications to the part and/or the documentation of the part, in order to implement improvements. Pasternack reserves the right to make such changes as required. Unless otherwise stated, all specifications are nominal.

## 086 Semi-rigid Coax Cable with Copper Outer Conductor

### TECHNICAL DATA SHEET

RG405/U

**Shield:**

Number of	1
Material 1	Copper
Diameter, in [mm]	0.087 [2.21]

**Jacket:**

Color	Tan
One Time Minimum Bend Radius, in [mm]	0.05 [1.27]
Weight, lbs/ft [Kg/m]	0.015 [0.02]

**Compliance Certifications** (visit [www.Pasternack.com](http://www.Pasternack.com) for current document)

RoHS Compliant	Yes
----------------	-----

**Plotted and Other Data**

Notes:	Values at 25 °C, sea level
--------	----------------------------

086 Semi-rigid Coax Cable with Copper Outer Conductor from Pasternack Enterprises has same day shipment for domestic and International orders. Our RF, microwave and fiber optic products maintain a 99% availability and are part of the broadest selection in the industry.

Click the following link (or enter part number in "SEARCH" on website) to obtain additional part information including price, inventory and certifications: [086 Semi-rigid Coax Cable with Copper Outer Conductor RG405/U](#)

URL: <http://www.pasternack.com/semirigid-0.085-rg405-50-ohm-coax-cable-copper-rg405-u-p.aspx>

The information contained in this document is accurate to the best of our knowledge and representative of the part described herein. It may be necessary to make modifications to the part and/or the documentation of the part, in order to implement improvements. Pasternack reserves the right to make such changes as required. Unless otherwise stated, all specifications are nominal.

# RG405/U CAD Drawing

086 Semi-rigid Coax Cable with Copper Outer Conductor



NOTES:  
 1. UNLESS OTHERWISE SPECIFIED ALL DIMENSIONS ARE NOMINAL.  
 2. ALL SPECIFICATIONS ARE SUBJECT TO CHANGE WITHOUT NOTICE AT ANY TIME.  
 3. DIMENSIONS ARE IN INCHES [mm].

DWG TITLE

**RG405/U**

FSCM NO. 53919

CAD FILE 022908

SCALE N/A

SIZE A

2233



**PASTERNAK**<sup>®</sup>  
 Pasternack Enterprises, Inc.  
 P.O. Box 16759 | Irvine | CA | 92623  
**Phone:** (949) 261-1920 | **Fax:** (949) 261-7451  
**Website:** www.pasternack.com | **E-Mail:** sales@pasternack.com