



BNC Male Right Angle Connector Crimp/Non-Solder Contact Attachment for LMR-240, LMR-240-DB, LMR-240-UF, LMR-240-FR, RG8X, PE-C240

## RF Connectors Technical Data Sheet



**EZ-240-BM-RA-X**

### Times Microwave Systems Connector Specification

#### Configuration

- BNC Male Connector
- 50 Ohms
- Right Angle Body Geometry
- Connector Interface Types: LMR-240, LMR-240-DB, LMR-240-UF, LMR-240-FR, RG8X, PE-C240

#### Features

- Max. Operating Frequency 6 GHz
- Good VSWR of 1.35:1
- Gold over nickel Plated Brass Contact
- 50  $\mu$ m minimum contact plating

#### Applications

- General Purpose Test
- Custom Cable Assemblies

#### Description

EZ-240-BM-RA-X BNC male right angle coaxial connector has an interface type of BNC male LMR-240, LMR-240-DB, LMR-240-UF, LMR-240-FR, RG8X, and PE-C240 and a 50 Ohms impedance. Pasternack's BNC male connector uses crimp/non-solder contact as an attachment method. Our male BNC right angle coaxial connector provides a maximum frequency of 6 GHz.

The Pasternack right angle BNC male coaxial connector has a teflon dielectric type and a VSWR of 1.35:1. Pasternack's BNC coaxial connector has a brass body with tri-metal plating. Our EZ-240-BM-RA-X BNC right angle connector uses a gold over nickel-plated brass contact. Additional RF connector specs and dimensions for this component can be found on its PDF specification datasheet and CAD drawings above.

The radio frequency connector is made from brass material and has a contact life of 500 cycles or more. Our high-quality EZ-240-BM-RA-X features an 80  $\mu$ m minimum body plating specification. The Pasternack EZ-240-BM-RA-X BNC connector operates at a temperature range of -55 to 155 deg C. The Pasternack BNC male connector has a maximum operating voltage of 500 Vrms.

This Pasternack right angle male BNC connector will ship the same business day as purchased. Our BNC right angle male connector is part of over 40,000 RF, microwave, and millimeter wave components in stock for local, domestic, and international shipment. For further information on similar products, our expert technical support and trained sales team can get you the ideal RF connector as per your requirements.

#### Electrical Specifications

Description	Minimum	Typical	Maximum	Units
Frequency Range	DC		6	GHz
VSWR			1.35:1	
Operating Voltage (AC)			500	Vrms
Impedance		50		Ohms
Dielectric Withstanding Voltage (DC)			750	Vdc
Insulation Resistance	5,000			MOhms

Click the following link (or enter part number in "SEARCH" on website) to obtain additional part information including price, inventory and certifications: [BNC Male Right Angle Connector Crimp/Non-Solder Contact Attachment for LMR-240, LMR-240-DB, LMR-240-UF, LMR-240-FR, RG8X, PE-C240 EZ-240-BM-RA-X](#)



BNC Male Right Angle Connector Crimp/Non-Solder Contact Attachment for LMR-240, LMR-240-DB, LMR-240-UF, LMR-240-FR, RG8X, PE-C240

**RF Connectors**  
**Technical Data Sheet**

**Mechanical Specifications**

**Size**

Length	1.32 in [33.53 mm]
Width	0.57 in [14.50 mm]
Height	1.19 in [30.10 mm]
Weight	0.10 lbs [45.36 g]
Mating Cycles	500 Cycles
Cable Retention Force	60 lbs 27.22 kg

**Material Specifications**

Description	Material	Plating
Contact	Brass	Gold over nickel 50 µin minimum
Insulation	Teflon	
Body	Brass	Tri-Metal 80 µin minimum
Crimp Sleeve	Brass	Tri-Metal 80 µin minimum

**Environmental Specifications**

**Temperature**

Operating Range	-55 to +155 deg C
Shock	US MIL-STD 202, Meth.213, Cond.I
Vibration	US MIL-STD 202, Meth.204, Cond.B
Thermal Shock	US MIL-STD 202, Meth.107, Cond.B

**Compliance Certifications** (see [product page](#) for current document)

**Plotted and Other Data**

Notes:

Click the following link (or enter part number in "SEARCH" on website) to obtain additional part information including price, inventory and certifications: [BNC Male Right Angle Connector Crimp/Non-Solder Contact Attachment for LMR-240, LMR-240-DB, LMR-240-UF, LMR-240-FR, RG8X, PE-C240 EZ-240-BM-RA-X](#)



BNC Male Right Angle Connector Crimp/Non-Solder  
Contact Attachment for LMR-240, LMR-240-DB,  
LMR-240-UF, LMR-240-FR, RG8X, PE-C240

## RF Connectors Technical Data Sheet



**EZ-240-BM-RA-X**

BNC Male Right Angle Connector Crimp/Non-Solder Contact Attachment for LMR-240, LMR-240-DB, LMR-240-UF, LMR-240-FR, RG8X, PE-C240 from Pasternack Enterprises has same day shipment for domestic and International orders. Our RF, microwave and millimeter wave products maintain a 99.4% availability and are part of the broadest selection in the industry.

Click the following link (or enter part number in "SEARCH" on website) to obtain additional part information including price, inventory and certifications: [BNC Male Right Angle Connector Crimp/Non-Solder Contact Attachment for LMR-240, LMR-240-DB, LMR-240-UF, LMR-240-FR, RG8X, PE-C240 EZ-240-BM-RA-X](https://www.pasternack.com/bnc-male-lmr-240-lmr-240-db-connector-ez-240-bm-ra-x-p.aspx)

URL: <https://www.pasternack.com/bnc-male-lmr-240-lmr-240-db-connector-ez-240-bm-ra-x-p.aspx>

The information contained in this document is accurate to the best of our knowledge and representative of the part described herein. It may be necessary to make modifications to the part and/or the documentation of the part, in order to implement improvements. Pasternack reserves the right to make such changes as required. Unless otherwise stated, all specifications are nominal. Pasternack does not make any representation or warranty regarding the suitability of the part described herein for any particular purpose, and Pasternack does not assume any liability arising out of the use of any part or documentation.

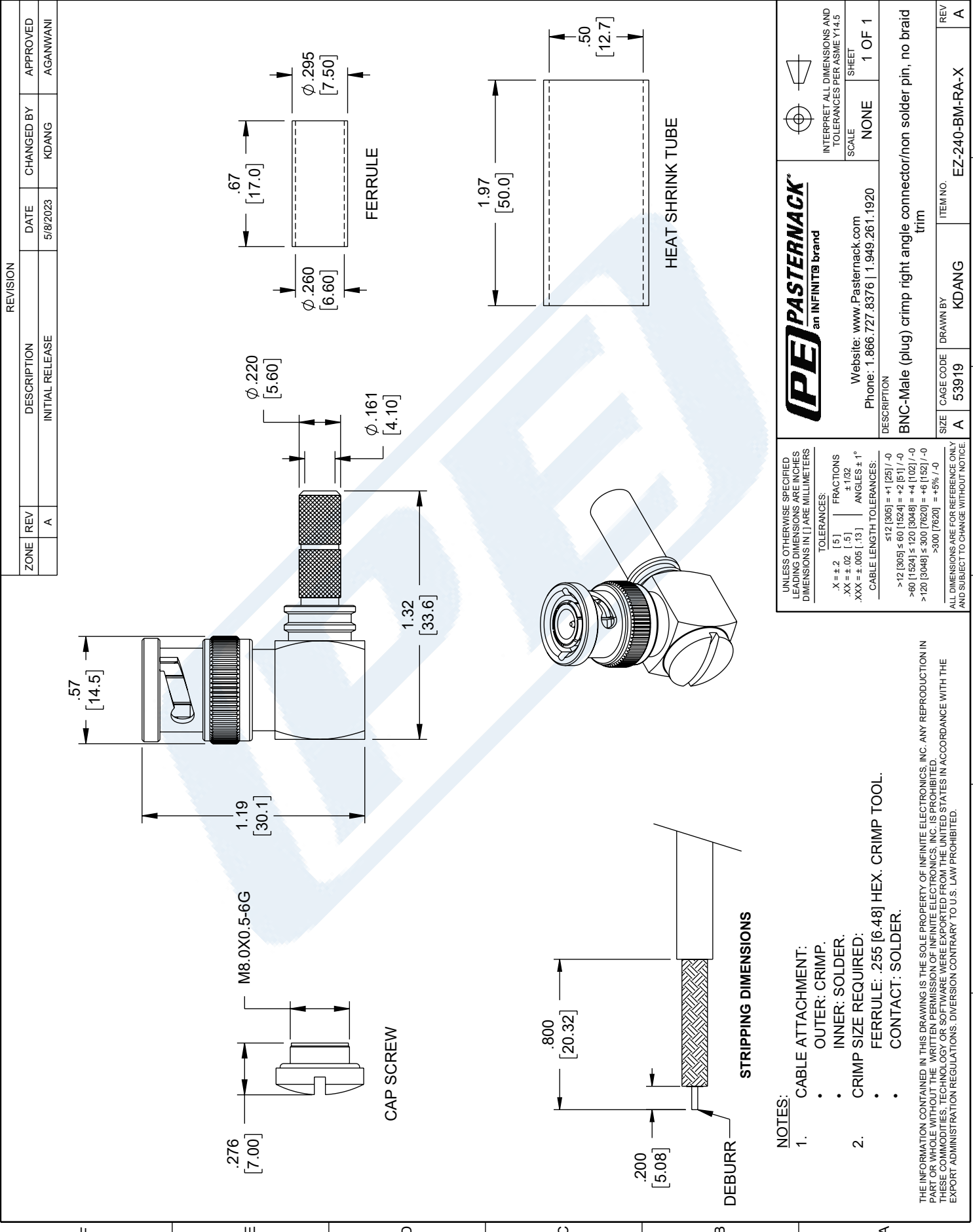

ZONE	REV	DESCRIPTION	DATE	CHANGED BY	APPROVED
	A	INITIAL RELEASE	5/19/2023	KDANG	AGANWANI

**PE PASTERNAK**  
an INFINITI® brand

Website: [www.Pasternack.com](http://www.Pasternack.com)  
Phone: 1.866.727.8376 | 1.949.261.1920

SCALE: NONE  
SHEET: 1 OF 1

INTERPRET ALL DIMENSIONS AND TOLERANCES PER ASME Y14.5

DESCRIPTION:  
BNC-Male (plug) crimp right angle connector/non solder pin, no braid trim

ITEM NO. EZ-240-BM-RA-X

REV A

UNLESS OTHERWISE SPECIFIED LEADING DIMENSIONS ARE INCHES DIMENSIONS IN [ ] ARE MILLIMETERS

TOLERANCES:

X = ± .2	[ .5 ]	FRACTIONS
.XX = ± .02	[ .5 ]	± 1/32
.XXX = ± .005	[ .13 ]	ANGLES ± 1°

CABLE LENGTH TOLERANCES:

≤ 12 [305]	± .125 [ -0 ]
> 12 [305]	± .60 [1524] = +2 [51] / -0
> 60 [1524]	± 120 [3048] = +4 [102] / -0
> 120 [3048]	± 300 [7620] = +6 [152] / -0
> 300 [7620]	± 6% / -0

ALL DIMENSIONS ARE FOR REFERENCE ONLY AND SUBJECT TO CHANGE WITHOUT NOTICE

- NOTES:
- CABLE ATTACHMENT:
    - OUTER: CRIMP.
    - INNER: SOLDER.
  - CRIMP SIZE REQUIRED:
    - FERRULE: .255 [6.48] HEX. CRIMP TOOL.
    - CONTACT: SOLDER.
- STRIPPING DIMENSIONS
- DEBURR
- CAP SCREW
- HEAT SHRINK TUBE
- FERRULE



N Female Connector Crimp/Non-Solder Contact Attachment for LMR-240, LMR-240-DB, LMR-240-UF, LMR-240-FR, RG8X, PE-C240

## RF Connectors Technical Data Sheet

## Times Microwave Systems Connector Specification

### Configuration

- N Female Connector
- 50 Ohms
- Straight Body Geometry
- Connector Interface Types: LMR-240, LMR-240-DB, LMR-240-UF, LMR-240-FR, RG8X, PE-C240

### Features

- Max. Operating Frequency 6 GHz
- Good VSWR of 1.3:1
- Gold over nickel Plated Phosphor Bronze Contact
- 50  $\mu$ m minimum contact plating

### Applications

- General Purpose Test
- Custom Cable Assemblies

### Description

EZ-240-NF-X BNC female coaxial connector has an interface type of BNC female LMR-240, LMR-240-DB, LMR-240-UF, LMR-240-FR, RG8X, and PE-C240 and a 50 Ohms impedance. Pasternack's BNC female connector uses crimp/non-solder contact as an attachment method. Our female BNC coaxial connector provides a maximum frequency of 6 GHz.

The Pasternack BNC female coaxial connector has a teflon dielectric type and a VSWR of 1.3:1. Pasternack's BNC coaxial connector has a brass body with tri-metal plating. Our EZ-240-NF-X BNC connector uses a gold over nickel-plated phosphor bronze contact. Additional RF connector specs and dimensions for this component can be found on its PDF specification datasheet and CAD drawings above.

The radio frequency connector is made from brass material and has a contact life of 500 cycles or more. Our high-quality EZ-240-NF-X features an 80  $\mu$ m minimum body plating specification. The Pasternack EZ-240-NF-X BNC connector operates at a temperature range of -55 to 155 deg C.

This Pasternack female BNC connector will ship the same business day as purchased. Our BNC female connector is part of over 40,000 RF, microwave, and millimeter wave components in stock for local, domestic, and international shipment. For further information on similar products, our expert technical support and trained sales team can get you the ideal RF connector as per your requirements.

### Electrical Specifications

Description	Minimum	Typical	Maximum	Units
Frequency Range	DC		6	GHz
VSWR			1.3:1	
Impedance		50		Ohms
Dielectric Withstanding Voltage (DC)			1,000	Vdc
Insulation Resistance	5,000			MOhms

Click the following link (or enter part number in "SEARCH" on website) to obtain additional part information including price, inventory and certifications: [N Female Connector Crimp/Non-Solder Contact Attachment for LMR-240, LMR-240-DB, LMR-240-UF, LMR-240-FR, RG8X, PE-C240 EZ-240-NF-X](#)



N Female Connector Crimp/Non-Solder Contact Attachment for LMR-240, LMR-240-DB, LMR-240-UF, LMR-240-FR, RG8X, PE-C240

## RF Connectors Technical Data Sheet

#### Mechanical Specifications

##### Size

Length	1.40 in [35.43 mm]
Width	0.62 in [15.80 mm]
Height	0.62 in [15.80 mm]
Weight	0.10 lbs [45.36 g]
Mating Cycles	500 Cycles

#### Material Specifications

Description	Material	Plating
Contact	Phosphor Bronze	Gold over nickel 50 µin minimum
Insulation	Teflon	
Body	Brass	Tri-Metal 80 µin minimum
Crimp Sleeve	Brass	Tri-Metal 80 µin minimum

#### Environmental Specifications

##### Temperature

Operating Range	-55 to +155 deg C
Shock	MIL-STD 202G, Meth.213, Cond I
Vibration	MIL-STD 202G, Meth.204, Cond.B
Thermal Shock	MIL-STD 202G, Meth.107, Cond.B

**Compliance Certifications** (see [product page](#) for current document)

#### Plotted and Other Data

Notes:

Click the following link (or enter part number in "SEARCH" on website) to obtain additional part information including price, inventory and certifications: [N Female Connector Crimp/Non-Solder Contact Attachment for LMR-240, LMR-240-DB, LMR-240-UF, LMR-240-FR, RG8X, PE-C240 EZ-240-NF-X](#)



N Female Connector Crimp/Non-Solder Contact Attachment for LMR-240, LMR-240-DB, LMR-240-UF, LMR-240-FR, RG8X, PE-C240

## RF Connectors Technical Data Sheet

N Female Connector Crimp/Non-Solder Contact Attachment for LMR-240, LMR-240-DB, LMR-240-UF, LMR-240-FR, RG8X, PE-C240 from Pasternack Enterprises has same day shipment for domestic and International orders. Our RF, microwave and millimeter wave products maintain a 99.4% availability and are part of the broadest selection in the industry.

Click the following link (or enter part number in "SEARCH" on website) to obtain additional part information including price, inventory and certifications: [N Female Connector Crimp/Non-Solder Contact Attachment for LMR-240, LMR-240-DB, LMR-240-UF, LMR-240-FR, RG8X, PE-C240 EZ-240-NF-X](https://www.pasternack.com/n-female-lmr-240-lmr-240-db-connector-ez-240-nf-x.aspx)

URL: <https://www.pasternack.com/n-female-lmr-240-lmr-240-db-connector-ez-240-nf-x.aspx>

The information contained in this document is accurate to the best of our knowledge and representative of the part described herein. It may be necessary to make modifications to the part and/or the documentation of the part, in order to implement improvements. Pasternack reserves the right to make such changes as required. Unless otherwise stated, all specifications are nominal. Pasternack does not make any representation or warranty regarding the suitability of the part described herein for any particular purpose, and Pasternack does not assume any liability arising out of the use of any part or documentation.





## Low PIM Flexible TCOM-240 Coax Cable Double Shielded with Black PE Jacket

### RF Cables Technical Data Sheet

## Times Microwave Systems Coax Cable Specification Configuration

- Low PIM Flexible Cable
- 2 Shield(s)

### Description

TCOM-240 part number from Pasternack is a low PIM coax cable that is flexible. Pasternack flexible coax RF cable has an impedance of 50 Ohm and a Foam PE dielectric. Our TCOM-240 coax cable is constructed with a 0.24-inch jacket made of polyethylene. This coaxial cable has a dielectric withstanding voltage of 1500 Vdc.

The TCOM-240 flexible RF cable has a shield count of 2 and RF shielding of 100 dB. Our coax cable from Pasternack has a maximum frequency of 10 GHz. The maximum passive intermodulation of this low PIM cable is -155 dBc. Additional specifications for this TCOM-240 double-shielded RF coaxial cable are on our downloadable PDF datasheet above.

Our TCOM-240 coax cable can operate at temperatures ranging from -40 to 85 degrees C. This black-colored flexible RF cable with a 50 Ohm impedance has a typical insertion loss/maximum attenuation of 26.2 dB/100ft at a frequency of 10 GHz. The TCOM-240 flexible RF cable has a solid copper center conductor. This coaxial cable features a dual shield of tinned copper braid over the silver plated copper braid.

Pasternack TCOM-240 low PIM coax cables are part of over 40,000 RF, microwave, and millimeter wave components. These flexible cables and our other RF parts are available for same-day shipping worldwide. Custom RF cable assemblies using TCOM-240 or other coax can be built and shipped the same business day as well.

### Electrical Specifications

Description	Minimum	Typical	Maximum	Units
Frequency Range	DC		10	GHz
Impedance		50		Ohms
Velocity of Propagation		84		%
Time Delay		1.21 [3.97]		ns/ft [ns/m]
Shielding Effectiveness	100			dB
Passive Intermodulation			-155	dBc
Dielectric Withstanding Voltage (DC)			1,500	Vdc
Jacket Spark			5,000	Vrms
Inner Conductor DC Resistance			3.2	Ohms/1000ft
Outer Conductor DC Resistance			2.06	Ohms/1000ft
Nominal Capacitance		24.2 [79.4]		pF/ft [pF/m]
Nominal Inductance		0.06 [0.2]		uH/ft [uH/m]
Input Power (Peak)			5.6	kWatts

Click the following link (or enter part number in "SEARCH" on website) to obtain additional part information including price, inventory and certifications: [Low PIM Flexible TCOM-240 Coax Cable Double Shielded with Black PE Jacket TCOM-240](#)



Low PIM Flexible TCOM-240 Coax Cable  
Double Shielded with Black PE Jacket

**RF Cables**  
**Technical Data Sheet**



**Performance by Frequency Band**

Description	F1	F2	F3	F4	F5	Units
Frequency	0.15	0.22	0.45	0.9	1.5	GHz
Attenuation, Typ	2.9	3.5	5	7.2	9.4	dB/100ft
	9.51	11.48	16.4	23.62	30.84	dB/100m
Input Power (CW), Max	700	570	400	280	210	Watts

Description	F6	F7	F8	F9	F10	Units
Frequency	1.8	2	2.5	5.8	10	GHz
Attenuation, Typ	10.3	10.9	12.3	19.4	26.2	dB/100ft
	33.79	35.76	40.35	63.65	85.96	dB/100m
Input Power (CW), Max	190	180	160	100	70	Watts

**Mechanical Specifications**

Diameter	0.24 in [6.1 mm]
Weight	0.03 lbs/ft [0.04 kg/m]
Min. Bend Radius (Installation)	0.75 in [19.05 mm]
Min. Bend Radius (Repeated)	2.5 in [63.5 mm]
Bending Moment	0.25 lbs-ft [0.34 N-m]
Tensile Strength	80 lbs [36.29 kg]
Flat Plate Crush	20 lbs/in [0.36 kg/mm]

**Construction Specifications**

Description	Material and Plating	Diameter
Inner Conductor	Copper, 1 Strand	0.056 in [1.42 mm]
Conductor Type	Solid	
Dielectric	PE (F)	0.15 in [3.81 mm]
First Shield	Silver Plated Copper Braid	0.16 in [4.06 mm]

Click the following link (or enter part number in "SEARCH" on website) to obtain additional part information including price, inventory and certifications: [Low PIM Flexible TCOM-240 Coax Cable Double Shielded with Black PE Jacket TCOM-240](#)



## Low PIM Flexible TCOM-240 Coax Cable Double Shielded with Black PE Jacket

### RF Cables Technical Data Sheet



**TCOM-240**

Second Shield	Tinned Copper Braid	0.188 in [4.78 mm]
Jacket	PE, Black	0.24 in [6.1 mm]

#### Environmental Specifications

##### Temperature

Operating Range	-40 to +85 deg C
Installation Range	-40 to +85 deg C
Storage Range	-70 to +85 deg C

#### Compliance Certifications (see [product page](#) for current document)

#### Plotted and Other Data

Notes:

Low PIM Flexible TCOM-240 Coax Cable Double Shielded with Black PE Jacket from Pasternack Enterprises has same day shipment for domestic and International orders. Our RF, microwave and millimeter wave products maintain a 99.4% availability and are part of the broadest selection in the industry.

Click the following link (or enter part number in "SEARCH" on website) to obtain additional part information including price, inventory and certifications: [Low PIM Flexible TCOM-240 Coax Cable Double Shielded with Black PE Jacket TCOM-240](#)

URL: <https://www.pasternack.com/low-pim-flexible-tcom240-pe-jacket-silver-plated-copper-braid-over-tinned-copper-braid-outer-conductor-double-shielded-tcom-240-p.aspx>

The information contained in this document is accurate to the best of our knowledge and representative of the part described herein. It may be necessary to make modifications to the part and/or the documentation of the part, in order to implement improvements. Pasternack reserves the right to make such changes as required. Unless otherwise stated, all specifications are nominal. Pasternack does not make any representation or warranty regarding the suitability of the part described herein for any particular purpose, and Pasternack does not assume any liability arising out of the use of any part or documentation.

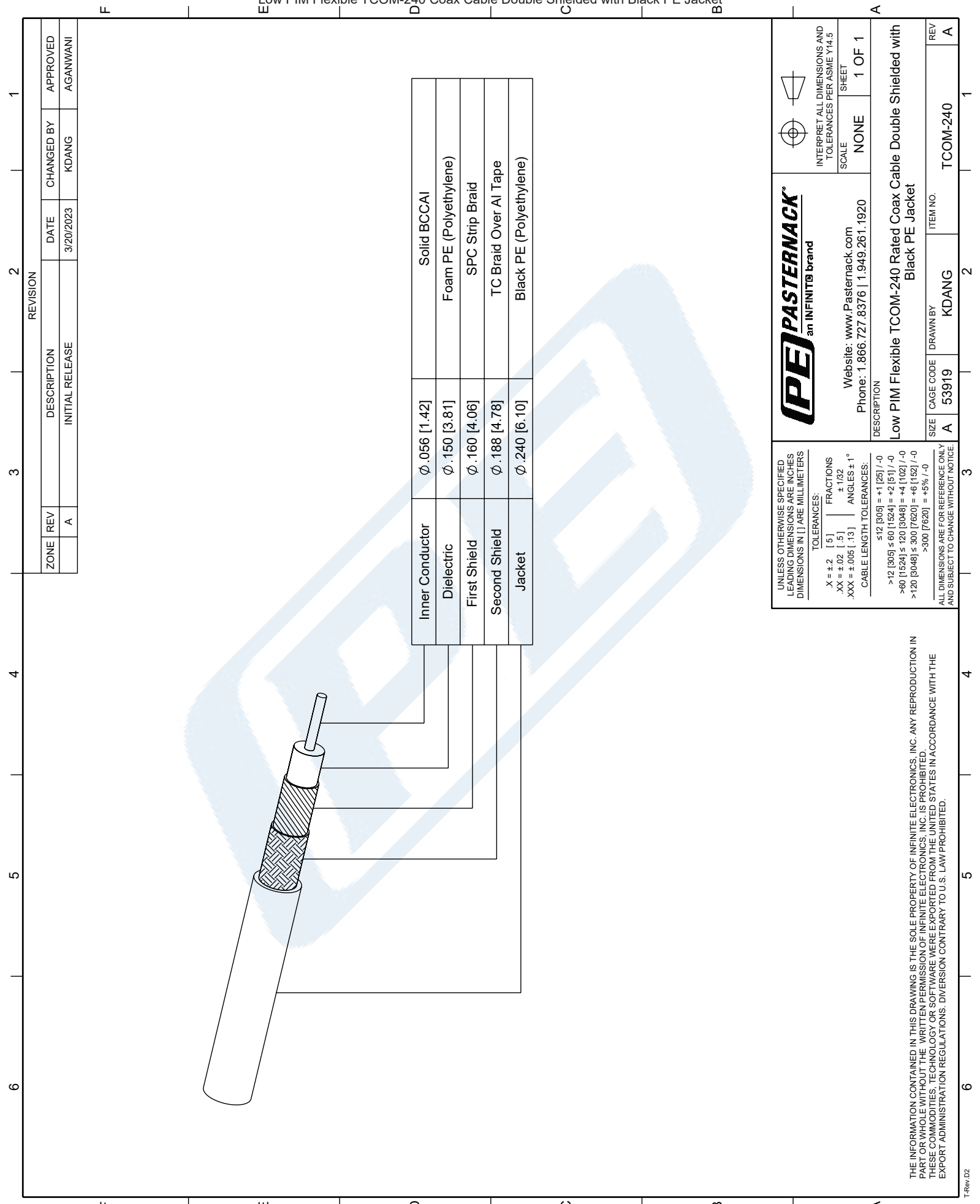

Inner Conductor	$\phi$ .056 [1.42]	Solid BCCA1
Dielectric	$\phi$ .150 [3.81]	Foam PE (Polyethylene)
First Shield	$\phi$ .160 [4.06]	SPC Strip Braid
Second Shield	$\phi$ .188 [4.78]	TC Braid Over Al Tape
Jacket	$\phi$ .240 [6.10]	Black PE (Polyethylene)

ZONE	REV	DESCRIPTION	DATE	CHANGED BY	APPROVED
	A	INITIAL RELEASE	3/20/2023	KDANG	AGANWANI

REVISION

UNLESS OTHERWISE SPECIFIED LEADING DIMENSIONS ARE INCHES DIMENSIONS IN [ ] ARE MILLIMETERS

TOLERANCES:  
 .X = ±.2 [ .5 ]      FRACTIONS ± 1/32  
 .XX = ±.02 [ .5 ]      ANGLES ± 1°  
 .XXX = ±.005 [ .13 ]

CABLE LENGTH TOLERANCES:  
 ≤12 [305] = +1 [25] / -0  
 >12 [305] ≤ 60 [1524] = +2 [51] / -0  
 >60 [1524] ≤ 120 [3048] = +4 [102] / -0  
 >120 [3048] ≤ 300 [7620] = +6 [152] / -0  
 >300 [7620] = +5% / -0

ALL DIMENSIONS ARE FOR REFERENCE ONLY AND SUBJECT TO CHANGE WITHOUT NOTICE

**PE PASTERNAK**  
 an INFINITI® brand

Website: [www.Pasternack.com](http://www.Pasternack.com)  
 Phone: 1.866.727.8376 | 1.949.261.1920

DESCRIPTION  
 Low PIM Flexible TCOM-240 Rated Coax Cable Double Shielded with Black PE Jacket

INTERPRET ALL DIMENSIONS AND TOLERANCES PER ASME Y14.5

SCALE NONE  
 SHEET 1 OF 1

THE INFORMATION CONTAINED IN THIS DRAWING IS THE SOLE PROPERTY OF INFINITE ELECTRONICS, INC. ANY REPRODUCTION IN PART OR WHOLE WITHOUT THE WRITTEN PERMISSION OF INFINITE ELECTRONICS, INC. IS PROHIBITED. THESE COMMODITIES, TECHNOLOGY OR SOFTWARE WERE EXPORTED FROM THE UNITED STATES IN ACCORDANCE WITH THE EXPORT ADMINISTRATION REGULATIONS. DIVERSION CONTRARY TO U.S. LAW PROHIBITED.

SIZE	CABLE CODE	DRAWN BY	ITEM NO.	REV
A	53919	KDANG	TCOM-240	A