



SMA Female Connector Crimp/Solder Attachment
 for PE-C400, PE-B400, PE-B405, LMR-400,
 LMR-400-DB, LMR-400-UF, 0.400 inch

RF Connectors Technical Data Sheet

PE44669

Configuration

- SMA Female Connector
- 50 Ohms
- Straight Body Geometry
- PE-C400, PE-B400, PE-B405, LMR-400, LMR-400-DB, LMR-400-UF, 0.400 inch Interface Type
- Crimp/Solder Attachment

Features

- Gold Plated Brass Contact

Applications

- General Purpose Test
- Custom Cable Assemblies

Description

Pasternack's PE44669 SMA female connector with crimp/solder attachment for PE-C400, PE-B400, PE-B405, LMR-400, LMR-400-DB, LMR-400-UF and 0.400 inch is part of our full line of RF components available for same-day shipping.

Our SMA female connector PE44669 datasheet specifications and drawing with dimensions are shown below in this PDF. Pasternack's broad catalog of RF, microwave and millimeter wave connectors allows designers to configure and customize their signal connections however they like. Whether the need is to provide an I/O for a board design, or simply create a custom cable assembly configuration, Pasternack has the right connector for the job. Pasternack can also expertly build your custom cable assemblies for you and ship same-day.

Mechanical Specifications

Size

Length	1.708 in [43.38 mm]
Width/Dia.	0.71 in [18.03 mm]
Weight	0.068 lbs [30.84 g]

Material Specifications

Description	Material	Plating
Contact	Brass	Gold
Insulation	PTFE	
Body	Brass	Gold

Click the following link (or enter part number in "SEARCH" on website) to obtain additional part information including price, inventory and certifications: [SMA Female Connector Crimp/Solder Attachment for PE-C400, PE-B400, PE-B405, LMR-400, LMR-400-DB, LMR-400-UF, 0.400 inch PE44669](#)



SMA Female Connector Crimp/Solder Attachment
for PE-C400, PE-B400, PE-B405, LMR-400,
LMR-400-DB, LMR-400-UF, 0.400 inch

RF Connectors Technical Data Sheet

PE44669

Compliance Certifications (see [product page](#) for current document)

Plotted and Other Data

Notes:

SMA Female Connector Crimp/Solder Attachment for PE-C400, PE-B400, PE-B405, LMR-400, LMR-400-DB, LMR-400-UF, 0.400 inch from Pasternack Enterprises has same day shipment for domestic and International orders. Our RF, microwave and millimeter wave products maintain a 99% availability and are part of the broadest selection in the industry.

Click the following link (or enter part number in "SEARCH" on website) to obtain additional part information including price, inventory and certifications: [SMA Female Connector Crimp/Solder Attachment for PE-C400, PE-B400, PE-B405, LMR-400, LMR-400-DB, LMR-400-UF, 0.400 inch PE44669](#)

URL: <https://www.pasternack.com/sma-female-standard-pe-c400-0.400-connector-pe44669-p.aspx>

The information contained in this document is accurate to the best of our knowledge and representative of the part described herein. It may be necessary to make modifications to the part and/or the documentation of the part, in order to implement improvements. Pasternack reserves the right to make such changes as required. Unless otherwise stated, all specifications are nominal. Pasternack does not make any representation or warranty regarding the suitability of the part described herein for any particular purpose, and Pasternack does not assume any liability arising out of the use of any part or documentation.

PE44669 CAD Drawing

SMA Female Connector Crimp/Solder Attachment for PE-C400, PE-B400, PE-B405, LMR-400, LMR-400-DB, LMR-400-UF, 0.400 inch

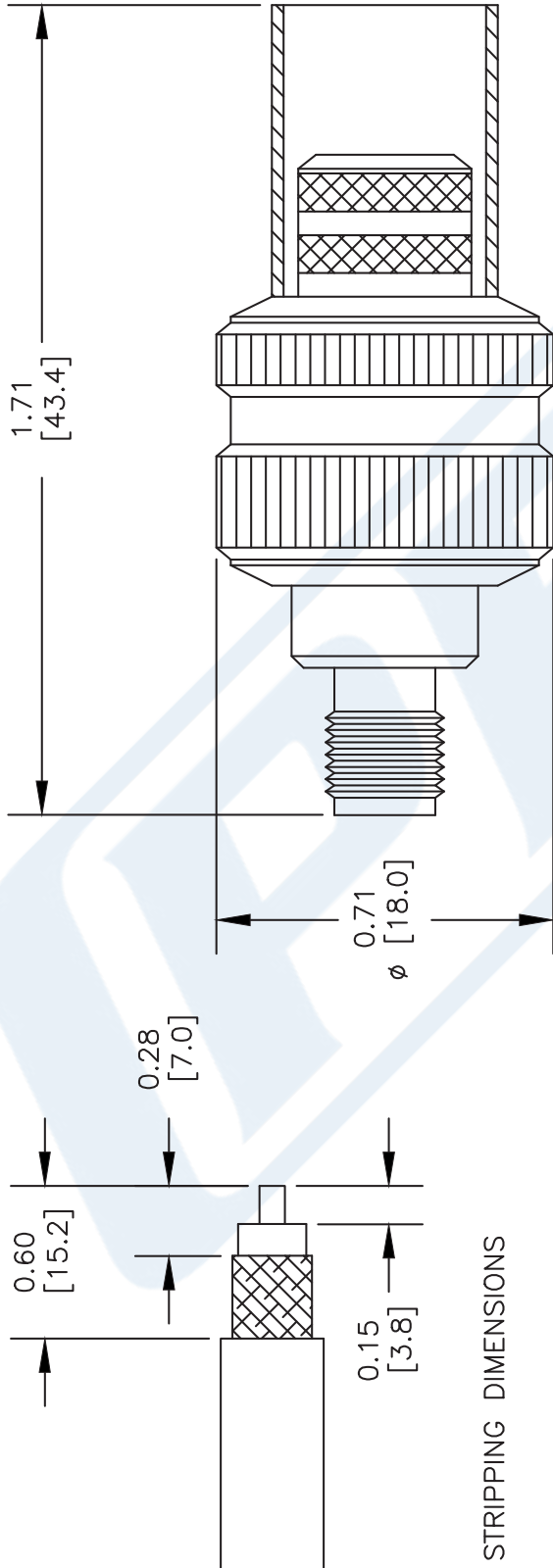

STRIPPING DIMENSIONS

CRIMP SIZE REQUIRED

CONTACT: SOLDER

FERRULE: .429" HEX CRIMP TOOL

DWG TITLE

PE44669

NOTES:

1. UNLESS OTHERWISE SPECIFIED ALL DIMENSIONS ARE NOMINAL.
2. ALL SPECIFICATIONS ARE SUBJECT TO CHANGE WITHOUT NOTICE AT ANY TIME.
3. DIMENSIONS ARE IN INCHES [mm].
4. FITS MIL-C-17 AND EQUIVALENT CABLES.

REV. -

FSCM NO. 53919

CAD FILE 102009

SCALE N/A

SIZE A

147

PE PASTERNAK®

Pasternack Enterprises, Inc.
 P.O. Box 16759 | Irvine | CA | 92623
 Phone: (949) 261-1920 | Fax: (949) 261-7451
 Website: www.pasternack.com | E-Mail: sales@pasternack.com



QN Male Right Angle Snap-On Connector Crimp/Solder Attachment for LMR-400, PE-C400, LMR-400-DB

RF Connectors Technical Data Sheet

PE45223

Configuration

- Snap-On QN Male Connector
- 50 Ohms
- Right Angle Body Geometry
- LMR-400, PE-C400, LMR-400-DB Interface Type
- Crimp/Solder Attachment

Features

- Operates to 6 GHz
- Quick Locking Snap On Connection
- Reduced connector to connector spacing
- 100 mating cycles
- No torque wrench required
- 360 degree rotation capability

Applications

- Telecommunication system
- Rack and Panel Mount Applications
- High connection density systems

Description

Pasternack's PE45223 Snap-On QN Male Right Angle connector is part of our full line of RF connectors available for same-day shipping. Our Male QN connector operates to 6 GHz. The PE45223 provides excellent VSWR of 1.5:1 maximum to 6 GHz. The PE45223 Pasternack RF connector is designed for use with LMR-400 and PE-C400 and is attached to the body using a crimp connection and the center contact employs a solder connection.

QN connectors allow for an easy snap-on connection that securely locks in place for an easy mating reliable connection. In addition to the time savings offered by the Snap-On interface the QMA interface allow for a tighter density than a Threaded N interface which requires the use of a torque wrench to properly complete the connection. The QN interface is operational to 6 GHz when used on LMR-400 Coaxial cable. This QN connector is QLF approved and insures intermateability with other QLF QN products.

Electrical Specifications

Description	Minimum	Typical	Maximum	Units
Frequency Range	DC		6	GHz
VSWR			1.5:1	
Operating Voltage (AC)			500	Vrms
Dielectric Withstanding Voltage (AC)			1,500	
Insulation Resistance	5,000			MOhms

Mechanical Specifications

Size

Length	1.43 in [36.32 mm]
Width/Dia.	0.75 in [19.05 mm]
Height	1.28 in [32.51 mm]

Click the following link (or enter part number in "SEARCH" on website) to obtain additional part information including price, inventory and certifications: [QN Male Right Angle Snap-On Connector Crimp/Solder Attachment for LMR-400, PE-C400, LMR-400-DB PE45223](#)



QN Male Right Angle Snap-On Connector Crimp/Solder Attachment for LMR-400, PE-C400, LMR-400-DB

RF Connectors Technical Data Sheet

PE45223

Weight	0.091 lbs [41.28 g]
Mating Cycles	100 Cycles

Material Specifications

Description	Material	Plating
Contact	Brass	Silver
Insulation	PTFE	
Body	Brass	Silver
Coupling Nut	Brass	Tri-Metal

Environmental Specifications

Temperature

Operating Range	-55 to 125 deg C
Hermetic Seal	ATM. cm ³ /s

Compliance Certifications (visit www.Pasternack.com for current document)

RoHS Compliant	
REACH Compliant	12/17/2015

Plotted and Other Data

Notes:

QN Male Right Angle Snap-On Connector Crimp/Solder Attachment for LMR-400, PE-C400, LMR-400-DB from Pasternack Enterprises has same day shipment for domestic and International orders. Our RF, microwave and millimeter wave products maintain a 99% availability and are part of the broadest selection in the industry.

Click the following link (or enter part number in "SEARCH" on website) to obtain additional part information including price, inventory and certifications: [QN Male Right Angle Snap-On Connector Crimp/Solder Attachment for LMR-400, PE-C400, LMR-400-DB PE45223](http://www.pasternack.com/qn-male-snap-on-lmr-400-pe-c400-lmr-400-db-connector-pe45223-p.aspx)

URL: <https://www.pasternack.com/qn-male-snap-on-lmr-400-pe-c400-lmr-400-db-connector-pe45223-p.aspx>

The information contained in this document is accurate to the best of our knowledge and representative of the part described herein. It may be necessary to make modifications to the part and/or the documentation of the part, in order to implement improvements. Pasternack reserves the right to make such changes as required. Unless otherwise stated, all specifications are nominal. Pasternack does not make any representation or warranty regarding the suitability of the part described herein for any particular purpose, and Pasternack does not assume any liability arising out of the use of any part or documentation.

PE45223 CAD Drawing

QN Male Right Angle Snap-On Connector Crimp/Solder
Attachment for LMR-400, PE-C400, LMR-400-DB

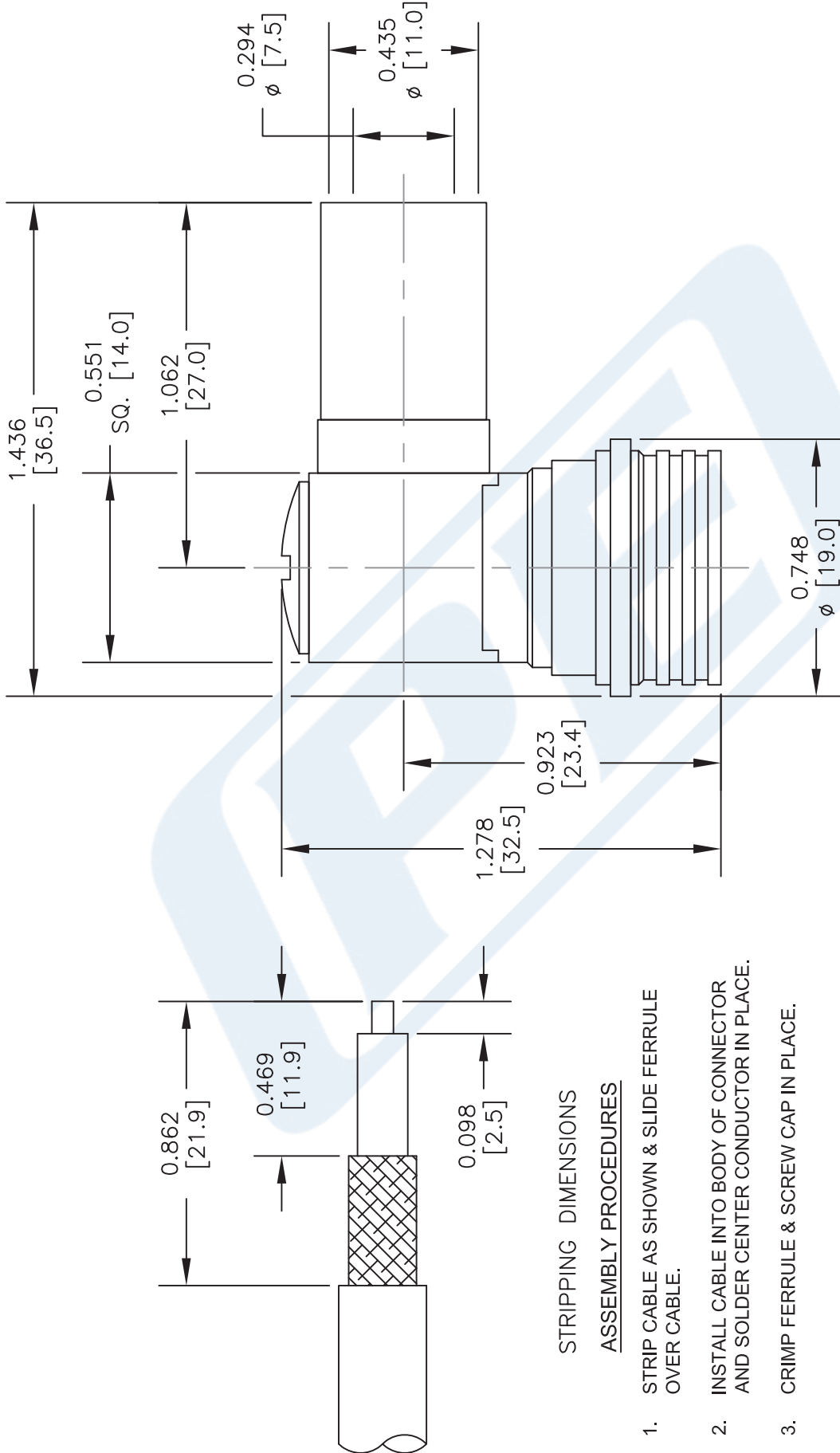

STRIPPING DIMENSIONS

ASSEMBLY PROCEDURES

1. STRIP CABLE AS SHOWN & SLIDE FERRULE OVER CABLE.
2. INSTALL CABLE INTO BODY OF CONNECTOR AND SOLDER CENTER CONDUCTOR IN PLACE.
3. CRIMP FERRULE & SCREW CAP IN PLACE.

CRIMP SIZE REQUIRED

CONTACT: SOLDER
FERRULE: .429" HEX CRIMP TOOL

DWG TITLE

PE45223

- NOTES:
1. UNLESS OTHERWISE SPECIFIED ALL DIMENSIONS ARE NOMINAL.
 2. ALL SPECIFICATIONS ARE SUBJECT TO CHANGE WITHOUT NOTICE AT ANY TIME.
 3. DIMENSIONS ARE IN INCHES [mm].
 4. FITS MIL-C-17 AND EQUIVALENT CABLES.

(PE) PASTERNAK®
THE ENGINEER'S RF SOURCE
Pasternack Enterprises, Inc.
P.O. Box 16759 | Irvine | CA | 92623
Phone: (949) 261-1920 | Fax: (949) 261-7451
Website: www.pasternack.com | E-Mail: sales@pasternack.com

FSCM NO. 53919

CAD FILE 062216

SCALE N/A

SIZE A

2233



LMR-LW400 Light weight version of the 400 series Low Loss Coax

Times Microwave Systems Coax Cable Specification

Configuration

- Low Loss, Outdoor Flexible Cable
- 2 Shield(s)

Features

- Light Weight Coax with Aluminum Shielding
- Max Operating Frequency of 8 GHz
- Phase Velocity 84% VoP
- Max Operating Temperature +85°C
- PE Jacket
- Min Install Bend Radius of 1 inches

Applications

- Antenna Installs
- RF Test Systems
- General Purpose RF Interconnect
- Laboratory Applications

Description

LMR-LW400 Light weight version of the 400 series Low Loss Coax from Times Microwave is part of the large product offering by Pasternack of radio frequency coaxial cable types specifically stocked to be ready for same-day shipment. Pasternack LMR-LW400 coax cable is manufactured in a flexible design and has a 50 Ohm impedance. This low loss and light weight flexible 50 Ohm coax cable LMR-LW400 is constructed with a 0.405 inch diameter and Black PE jacket.

LMR-LW400 flexible 50 Ohm coax cable with PE jacket is rated for a 8 GHz maximum operating frequency. This 50 Ohm 0.405 inch diameter and low loss flexible coax cable is built with an aluminum double shield count and RF shielding of 90 dB. Times Microwave LMR-LW400 PE coax is constructed with Foam PE dielectric and a maximum operating temperature of 85 degrees C. Pasternack's offering of LMR-LW400 coax cable provides specs for this wire on its RF coax cable LMR-LW400 datasheet.

LMR-LW400 cable is part of more than one million RF, microwave parts in stock at Pasternack. This Times Microwave low loss and light weight LMR-LW400 coax cable is ready to buy and can be shipped worldwide. Pasternack also maintains a wide selection of other radio frequency coaxial cable types that ship same-day from our warehouse as with the rest of our other RF/microwave components.

* LMR™ is a trademark of Times Microwave Systems.

Electrical Specifications

Description	Minimum	Typical	Maximum	Units
Frequency Range	DC		8	GHz
Impedance		50		Ohms
Velocity of Propagation		84		%
Time Delay		1.2 [3.94]		ns/ft [ns/m]
Shielding Effectiveness	90			dB
Dielectric Withstanding Voltage (DC)			2,500	Vdc
Jacket Spark			8,000	Vrms

Click the following link (or enter part number in "SEARCH" on website) to obtain additional part information including price, inventory and certifications: [LMR-LW400 Light weight version of the 400 series Low Loss Coax LMR-LW400](#)



LMR-LW400 Light weight version of the 400 series Low Loss Coax

RF Cables Technical Data Sheet



LMR-LW400

Inner Conductor DC Resistance	1.39	Ohms/1000ft
Outer Conductor DC Resistance	6.1	Ohms/1000ft
Nominal Capacitance	23.9 [78.41]	pF/ft [pF/m]
Nominal Inductance	0.06 [0.2]	uH/ft [uH/m]
Input Power (Peak)	16	kWatts

Performance by Frequency Band

Description	F1	F2	F3	F4	F5	Units
Frequency	0.05	0.15	0.45	0.9	1.5	GHz
Attenuation, Typ	0.9	1.5	2.7	3.9	5.1	dB/100ft
	2.95	4.92	8.86	12.8	16.73	dB/100m
Input Power (CW), Max	2,570	1,470	830	580	440	Watts

Description	F6	F7	F8	F9	F10	Units
Frequency	1.8	2	2.5	5.8	8	GHz
Attenuation, Typ	5.7	6	6.8	10.8	13	dB/100ft
	18.7	19.69	22.31	35.43	42.65	dB/100m
Input Power (CW), Max	400	370	330	210	170	Watts

Mechanical Specifications

Diameter	0.405 in [10.29 mm]
Weight	0.05 lbs/ft [0.07 kg/m]
Min. Bend Radius (Installation)	1 in [25.4 mm]
Min. Bend Radius (Repeated)	4 in [101.6 mm]
Bending Moment	0.5 lbs-ft [0.68 N-m]
Tensile Strength	160 lbs [72.57 kg]
Flat Plate Crush	40 lbs/in [0.71 kg/mm]

Construction Specifications

Description	Material and Plating	Diameter
Inner Conductor	Copper, 1 Strand	0.108 in [2.74 mm]
Conductor Type	Solid	

Click the following link (or enter part number in "SEARCH" on website) to obtain additional part information including price, inventory and certifications: [LMR-LW400 Light weight version of the 400 series Low Loss Coax LMR-LW400](#)



LMR-LW400 Light weight version of the 400 series Low Loss Coax

RF Cables Technical Data Sheet



LMR-LW400

Dielectric	Foam PE	0.285 in [7.24 mm]
First Shield	Aluminum Tape	[]
Second Shield	Aluminium	[]
Jacket	PE, Black	0.405 in [10.29 mm]

Environmental Specifications

Temperature

Operating Range	-40 to +85 deg C
Installation Range	-40 to +85 deg C
Storage Range	-70 to +85 deg C

Compliance Certifications (see [product page](#) for current document)

Plotted and Other Data

Notes:

LMR-LW400 Light weight version of the 400 series Low Loss Coax from Pasternack Enterprises has same day shipment for domestic and International orders. Our RF, microwave and millimeter wave products maintain a 99.4% availability and are part of the broadest selection in the industry.

Click the following link (or enter part number in "SEARCH" on website) to obtain additional part information including price, inventory and certifications: [LMR-LW400 Light weight version of the 400 series Low Loss Coax LMR-LW400](#)

URL: <https://www.pasternack.com/low-loss-flexible-lmr-lw400-pe-jacket-aluminum-tape-over-aluminium-outer-conductor-double-shielded-lmr-lw400-p.aspx>

The information contained in this document is accurate to the best of our knowledge and representative of the part described herein. It may be necessary to make modifications to the part and/or the documentation of the part, in order to implement improvements. Pasternack reserves the right to make such changes as required. Unless otherwise stated, all specifications are nominal. Pasternack does not make any representation or warranty regarding the suitability of the part described herein for any particular purpose, and Pasternack does not assume any liability arising out of the use of any part or documentation.

REVISIONS		
REV.	DESCRIPTION	DATE
A	INITIAL RELEASE	06-04-2021
		APPROVED
		SELLIS

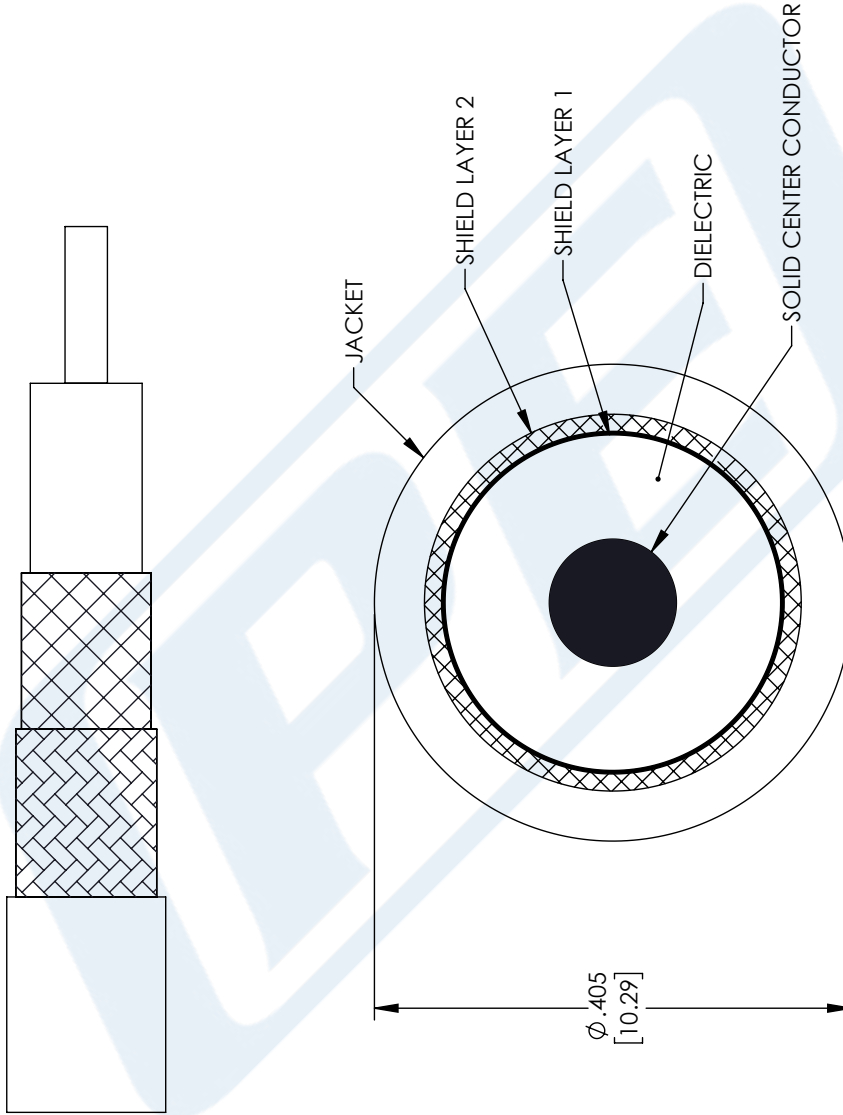

UNLESS OTHERWISE SPECIFIED
 LEADING DIMENSIONS ARE INCHES
 DIMENSIONS IN [] ARE MILLIMETERS

TOLERANCES:
 .X = ±.2 [5.08] FRACTIONS ± 1/32
 .XX = ±.02 [.51] ANGLES ± 1°
 .XXX = ±.005 [.13]

CABLE LENGTH (L) TOLERANCES:
 L ≤ 12 [305] = +1 [25] / -0
 12 [305] < L ≤ 60 [1524] = +2 [51] / -0
 60 [1524] < L ≤ 120 [3048] = +4 [102] / -0
 120 [3048] < L ≤ 300 [7620] = +6 [152] / -0
 300 [7620] < L = +5% / -0

ALL DIMENSIONS SHOWN
 ARE FOR REFERENCE ONLY.

PE PASTERNAK
 an INFINITI brand

Pasternack Enterprises, Inc.
 P. O. Box 16759, Irvine, CA 92623.
 Phone: 1.949.261.1920 | 1.866.727.8376
 Fax: 1.949.261.7451
 Website: www.pasternack.com
 E-mail: sales@pasternack.com

ITEM NO. LMR-LW400
 DRAWN BY MVEERAPPAN
 SIZE A
 CAGE CODE 53919

THIRD-ANGLE PROJECTION

THE INFORMATION AND
 DESIGN IN THIS DOCUMENT
 IS THE PROPERTY OF
 PASTERNAK CORPORATION
 ALL RIGHTS RESERVED.

SHEET 1 OF 1
 SCALE N/A
 REV A