

NOTICE OF PROPRIETARY RIGHTS THIS DOCUMENT CONTAINS CONFIDENTIAL TECHNICAL DATA, INCLUDING TRADE SECRETS, PROPRIETARY TO TIMES MICROWAVE SYSTEMS. DISCLOSURE OF THIS DATA IS EXPRESSLY CONDITIONED UPON YOUR ASSENT THAT ITS USE IS LIMITED TO USE WITHIN YOUR COMPANY ONLY. ANY OTHER USE IS STRICTLY PROHIBITED WITHOUT THE PRIOR WRITTEN CONSENT OF TIMES MICROWAVE SYSTEMS.

| SYM | REVISION DESCRIPTION | DFTM | DATE | APPD | DATE |
|-----|-------------------------|---------|--------|----------|---------|
| A | RELEASED FOR PRODUCTION | N. N. N | 9/4/13 | J. D. B. | 9/10/13 |

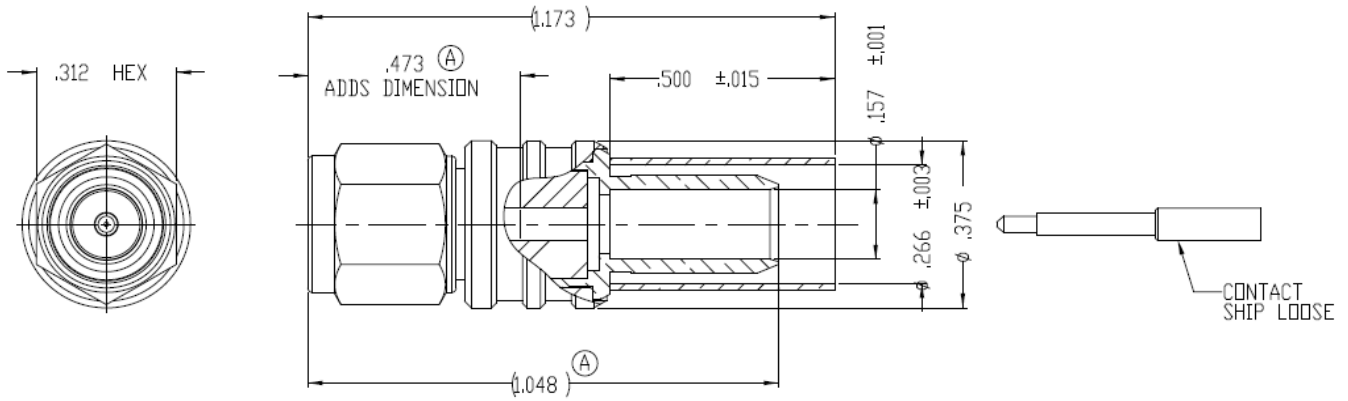

NOTES:

- ASSEMBLED CONNECTOR INTERFACE IS DESIGNED IN ACCORDANCE WITH MIL-STD-348
- MATERIAL:**

CLAMP & CONTACT - BRASS PER ASTM B16, C36000 ALLOY, TEMPER H02
 BODY, CNUT - STAINLESS STEEL PER ASTM 582, S30300 ALLOY, COND. A
 INSULATOR - TEFLON PER ASTM D1710, TYPE 1, GRADE 1, CLASS A
 GASKET - SILICONE RUBBER PER A-A-59588, 50-75 DUROMETER
 SHRINK SLEEVE - HEAT SHRINKABLE ATUM PER MIL-I-23053/4 (NOT SHOWN)
 CRIMP SLEEVE - D.H.P. COPPER CDA, ALLOY #122, TEMPER HARD
 CONTACT & LOCKING RING - BERYLLIUM COPPER PER ASTM B196, C17300 ALLOY, CONDITION HT

- FINISH:**
 CONTACT - GOLD PLATE PER ASTM B488
 CRIMP SLEEVE - SULFAMATE NICKEL PER MIL-P-27418
 CLAMP - NICKEL PLATE PER AMS-QQ-N-290
 C'NUT & BODY - PASSIVATE PER SAE-AMS-2700

| | | | | | |
|-------------|--|------------------|----------------|--|--------------------------|
| MATL: | UNLESS OTHERWISE SPECIFIED | | DFTM. N. N. N | TIMES MICROWAVE SYSTEMS | |
| | ALL DIMENSIONS ARE IN INCHES MACHINED SURFACES FINISH 63 RMS MAX. REMOVE ALL BURRS .004 MAX. BREAK MACHINE CORNERS .005 MAX. FILLET R. TOLERANCES ON DECIMALS . XX ± .01 . XXX ± .005 ANGLES ± 1° FRACTIONS ± 1/64 | | DATE 9/4/13 | | |
| USED ON: A | DO NOT SCALE DRAWING | | CHKD. J. D. B. | TC-240-SM-SS-X CONNECTOR ASSEMBLY SMAM for LMR-240 | |
| | | | DATE 9/10/13 | | |
| SCALE: NONE | DWG. SIZE A | CODE IDENT 68999 | APPD. J. D. B. | DATE 9/10/13 | 1 of 1 SD3190-2898 A |



4.3-10 Male Connector Crimp/Non-Solder Contact Attachment for LMR-240

RF Connectors Technical Data Sheet

EZ-240-4310M-X

Times Microwave Systems Connector Specification

Configuration

- 4.3-10 Male Connector
- 50 Ohms
- Straight Body Geometry
- LMR-240 Interface Type
- Crimp/Non-Solder Contact Attachment

Features

- Max. Operating Frequency 6 GHz
- Good VSWR of 1.3:1
- Gold Plated Beryllium Copper Contact

Applications

- General Purpose Test
- Custom Cable Assemblies
- Mobile Communications Systems
- Base Stations
- Distributed Antenna Systems (DAS)
- Small Cells
- Feeder Cables

Description

The Times Microwave EZ-240-4310M-X 4.3-10 male connector with crimp/non-solder attachment for LMR-240 is part of our full line of RF components available for same-day shipping. This 4.3-10 male connector operates up to a maximum frequency of 6 GHz and offers good VSWR of 1.3:1.

Our datasheet specifications and drawing with dimensions for Times Microwave's 4.3-10 male connector TC-240-4310M-X are shown below in this PDF. Pasternack's broad catalog of RF, microwave and millimeter wave connectors allows designers to configure and customize their signal connections however they like. Whether the need is to provide an I/O for a board design, or simply create a custom cable assembly configuration, Pasternack has the right connector for the job. Pasternack can also expertly build your custom cable assemblies for you and ship same-day.

Electrical Specifications

| Description | Minimum | Typical | Maximum | Units |
|-----------------------|---------|---------|---------|-------|
| Frequency Range | DC | | 6 | GHz |
| VSWR | | | 1.3:1 | |
| Insulation Resistance | 10,000 | | | MOhms |

Electrical Specification Notes:
 Insertion Loss = 0.1 x SQRT(FGHz)

Mechanical Specifications

Mating Cycles 500 Cycles

Click the following link (or enter part number in "SEARCH" on website) to obtain additional part information including price, inventory and certifications: [4.3-10 Male Connector Crimp/Non-Solder Contact Attachment for LMR-240 EZ-240-4310M-X](#)



4.3-10 Male Connector Crimp/Non-Solder Contact Attachment for LMR-240

RF Connectors
Technical Data Sheet



EZ-240-4310M-X

Material Specifications

| Description | Material | Plating |
|--------------|------------------|-----------|
| Contact | Beryllium Copper | Gold |
| Insulation | PTFE | |
| Body | Brass | Tri-Metal |
| Coupling Nut | Brass | Tri-Metal |
| Gasket | Silicone | |
| Crimp Sleeve | Brass | Tri-Metal |

Environmental Specifications

Temperature

Operating Range

-40 to +125 deg C

Shock

MIL-STD 202G, Meth. 204, Cond. B

Vibration

MIL-STD 202G, Meth. 213, Cond. I

Thermal Shock

MIL-STD 202G, Meth. 107, Cond. B

Compliance Certifications (see [product page](#) for current document)

Plotted and Other Data

Notes:

Click the following link (or enter part number in "SEARCH" on website) to obtain additional part information including price, inventory and certifications: [4.3-10 Male Connector Crimp/Non-Solder Contact Attachment for LMR-240 EZ-240-4310M-X](#)



4.3-10 Male Connector Crimp/Non-Solder Contact Attachment for LMR-240

RF Connectors Technical Data Sheet

Assembly Instruction

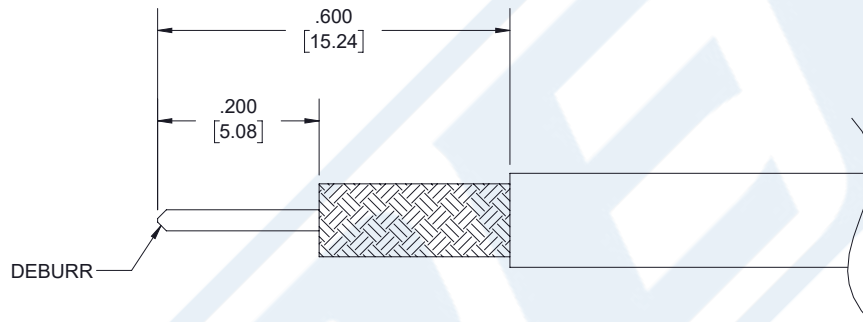

ASSEMBLY PROCEDURES

1. STRIP CABLE TO THE DIMENSIONS SHOWN, CHAMFER CENTER CONDUCTOR AND DEBURR CABLE.
2. SLIDE FERRULE OVER CABLE. INSTALL CABLE INTO BODY OF CONNECTOR UNTIL IT SEATS IN PLACE.
3. SLIDE FERRULE FORWARD AND AGAINST SHOULDER OF CONNECTOR AND CRIMP.

CRIMP SIZE REQUIRED

- FERRULE: .255" [6.48] HEX CRIMP TOOL.

Click the following link (or enter part number in "SEARCH" on website) to obtain additional part information including price, inventory and certifications: [4.3-10 Male Connector Crimp/Non-Solder Contact Attachment for LMR-240 EZ-240-4310M-X](#)



4.3-10 Male Connector Crimp/Non-Solder Contact Attachment for LMR-240

RF Connectors Technical Data Sheet



EZ-240-4310M-X

4.3-10 Male Connector Crimp/Non-Solder Contact Attachment for LMR-240 from Pasternack Enterprises has same day shipment for domestic and International orders. Our RF, microwave and millimeter wave products maintain a 99.4% availability and are part of the broadest selection in the industry.

Click the following link (or enter part number in "SEARCH" on website) to obtain additional part information including price, inventory and certifications: [4.3-10 Male Connector Crimp/Non-Solder Contact Attachment for LMR-240 EZ-240-4310M-X](https://www.pasternack.com/4.3-10-male-lmr-240-connector-ez-240-4310m-x-p.aspx)

URL: <https://www.pasternack.com/4.3-10-male-lmr-240-connector-ez-240-4310m-x-p.aspx>

The information contained in this document is accurate to the best of our knowledge and representative of the part described herein. It may be necessary to make modifications to the part and/or the documentation of the part, in order to implement improvements. Pasternack reserves the right to make such changes as required. Unless otherwise stated, all specifications are nominal. Pasternack does not make any representation or warranty regarding the suitability of the part described herein for any particular purpose, and Pasternack does not assume any liability arising out of the use of any part or documentation.

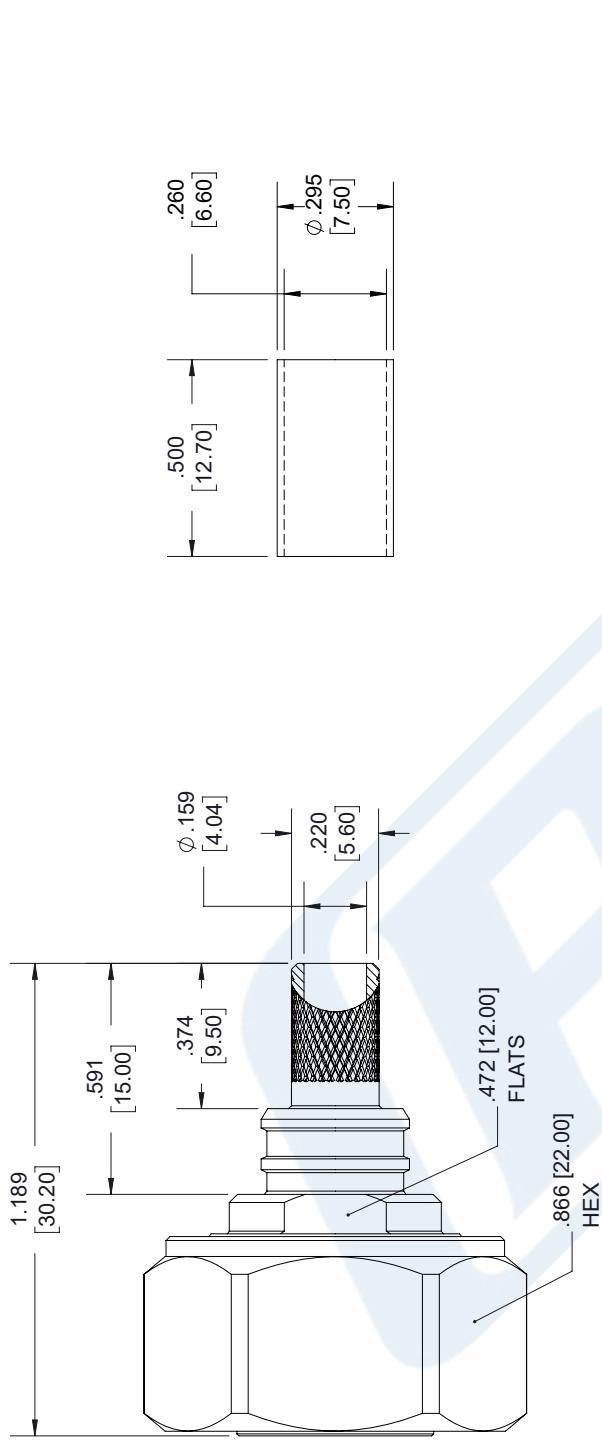

4.3-10 MALE

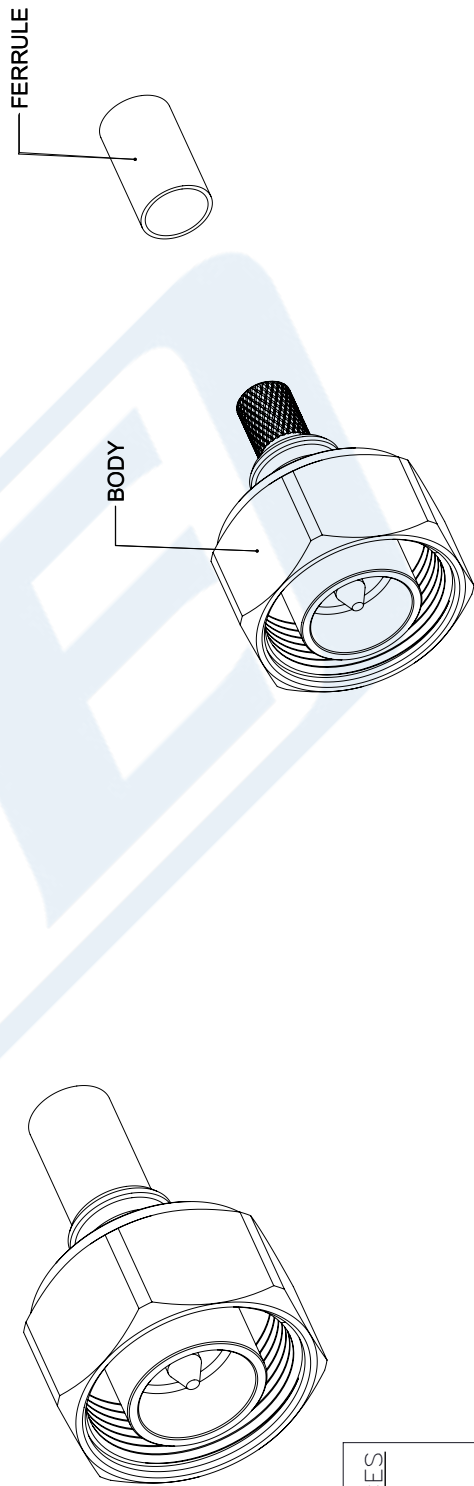

| STANDARD TOLERANCES | |
|---------------------|--------|
| .X | ±0.2 |
| .XX | ±0.01 |
| .XXX | ±0.005 |

*STANDARD TOLERANCES APPLY ONLY TO DIMENSIONS IN INCHES



Pasternack Enterprises, Inc.
 P.O. Box 16759 | Irvine | CA | 92623
Phone: (949) 261-1920 | **Fax:** (949) 261-7451
Website: www.pasternack.com | **E-Mail:** sales@pasternack.com

DWG TITLE

EZ-240-4310M-X

NOTES:
 1. UNLESS OTHERWISE SPECIFIED ALL DIMENSIONS ARE NOMINAL.
 2. ALL SPECIFICATIONS ARE SUBJECT TO CHANGE WITHOUT NOTICE AT ANY TIME.
 3. DIMENSIONS ARE IN INCHES [mm].

CAGE CODE 53919

CAD FILE 04/18/18

SCALE N/A

SIZE A

7361

LMR[®]-240 Flexible Low Loss Communications Coax

Ideal for...

- Jumper Assemblies in Wireless Communications Systems
- Short Antenna Feeder runs (e.g. WLL, GPS, LMR, Mobile Antennas)
- Any application (e.g. WLL, GPS, LMR, WLAN, WISP, WiMax, SCADA, Mobile Antennas) requiring an easily routed, low loss RF cable



• **LMR[®]** standard is a UV Resistant Polyethylene jacketed cable designed for 20-year service outdoor use. The bending and handling characteristics are significantly better than air-dielectric and corrugated hard-line cables.

• **LMR[®]-DB** is identical to standard LMR plus has the advantage of being watertight. The addition of waterproofing compound in and around the foil/braid insures continuous reliable service should the jacket be inadvertently damaged during installation or in the future.

• **LMR[®]-FR** is a non-halogen (non-toxic), low smoke, fire retardant cable designed for in-building runs that can be routed anywhere except air handling plenums. LMR-FR is UL/NEC & CSA rated 'CMR' and 'FT4' respectively, meets FAA FAR25 requirements and is MSHA-P for mining applications.

• **LMR[®]-FR-PVC** is a general-purpose indoor cable and has a UL/NEC & CSA rating of 'CMR' and 'FT4' respectively. It is less expensive than LMR-FR, however it emits toxic fumes (HCL) and greater smoke density when burned.

• **LMR[®]-PVC** is designed for low loss general-purpose applications and is somewhat more flexible than the standard polyethylene jacketed LMR.

• **LMR[®]-PVC-W** is a white-jacketed version of LMR-PVC for marine and other applications where color compatibility is desired.

• **LMR[®]-MA** is a flexible cable designed specifically for mobile antenna applications. It has a PVC jacket and un-bonded aluminum tape to facilitate end stripping with automated equipment.

• **Flexibility** and bendability are hallmarks of the LMR-240 cable design. The flexible outer conductor enables the tightest bend radius available for any cable of similar size and performance.

• **Low Loss** is another hallmark feature of LMR-240. Size for size LMR has the lowest loss of any flexible cable and comparable loss to semirigid hard-line cables.

• **RF Shielding** is 50 dB greater than typical single shielded coax (40 dB). The multi-ply bonded foil outer conductor is rated conservatively at > 90 dB (i.e. >180 dB between two adjacent cables).

• **Weatherability:** LMR-240 cables designed for outdoor exposure incorporate the best materials for UV resistance and have life expectancy in excess of 20 years.

• **Connectors:** A wide variety of connectors are available for LMR-240 cable, including all common interface types, reverse polarity, and a choice of solder or non-solder center pins. Most LMR connectors employ crimp outer attachment using standard hex crimp sizes.

• **Cable Assemblies:** All LMR-240 cable types are available as pre-terminated cable assemblies. Refer to the section on FlexTech for further details.

| Part Description | | | | | Stock |
|------------------|-------------------------|-----------|-------|-------|-------|
| Part Number | Application | Jacket | Color | Code | |
| LMR-240 | Outdoor | PE | Black | 54021 | |
| LMR-240-DB | Outdoor/Watertight | PE | Black | 54090 | |
| LMR-240-FR | Indoor/Outdoor Riser | CMR FRPE | Black | 54029 | |
| LMR-240-FR-PVC | Indoor/Outdoor Riser | CMR FRPVC | Black | 54214 | |
| LMR-240-PVC | General Purpose | PVC | Black | 54140 | |
| LMR-240-PVC-W | General Purpose | PVC | White | 54202 | |
| LMR-240-MA | Indoor & Mobile Antenna | PVC | Black | 54046 | |

| Construction Specifications | | | |
|-----------------------------|-------------------|-------|--------|
| Description | Material | In. | (mm) |
| Inner Conductor | Solid BC | 0.056 | (1.42) |
| Dielectric | Foam PE | 0.150 | (3.81) |
| Outer Conductor | Aluminum Tape | 0.155 | (3.94) |
| Overall Braid | Tinned Copper | 0.178 | (4.52) |
| Jacket | (see table above) | 0.240 | (6.10) |

| Mechanical Specifications | | | |
|---------------------------|----------------|-------|----------|
| Performance Property | Units | US | (metric) |
| Bend Radius: installation | in. (mm) | 0.75 | (19.1) |
| Bend Radius: repeated | in. (mm) | 2.5 | (63.5) |
| Bending Moment | ft-lb (N-m) | 0.25 | (0.34) |
| Weight | lb/ft (kg/m) | 0.034 | (0.05) |
| Tensile Strength | lb (kg) | 80 | (36.3) |
| Flat Plate Crush | lb/in. (kg/mm) | 20 | (0.36) |

| Environmental Specifications | | |
|--------------------------------|----------|---------|
| Performance Property | °F | °C |
| Installation Temperature Range | -40/+185 | -40/+85 |
| Storage Temperature Range | -94/+185 | -70/+85 |
| Operating Temperature Range | -40/+185 | -40/+85 |

| Electrical Specifications | | | |
|---------------------------|-------------------|-------|----------|
| Performance Property | Units | US | (metric) |
| Velocity of Propagation | % | 84 | |
| Dielectric Constant | NA | 1.42 | |
| Time Delay | nS/ft (nS/m) | 1.21 | (3.97) |
| Impedance | ohms | 50 | |
| Capacitance | pF/ft (pF/m) | 24.2 | (79.4) |
| Inductance | uH/ft (uH/m) | 0.060 | (0.20) |
| Shielding Effectiveness | dB | >90 | |
| DC Resistance | | | |
| Inner Conductor | ohms/1000ft (/km) | 3.2 | (10.5) |
| Outer Conductor | ohms/1000ft (/km) | 3.89 | (12.8) |
| Voltage Withstand | Volts DC | | 1500 |
| Jacket Spark | Volts RMS | | 5000 |
| Peak Power | kW | | 5.6 |

Attenuation vs. Frequency (typical)

| Frequency (MHz) | 30 | 50 | 150 | 220 | 450 | 900 | 1500 | 1800 | 2000 | 2500 | 5800 |
|------------------------------|------|------|------|------|------|------|------|------|------|------|------|
| Attenuation dB/100 ft | 1.3 | 1.7 | 3.0 | 3.7 | 5.3 | 7.6 | 9.9 | 10.9 | 11.5 | 12.9 | 20.4 |
| Attenuation dB/100 m | 4.4 | 5.7 | 9.9 | 12.0 | 17.3 | 24.8 | 32.4 | 35.6 | 37.7 | 42.4 | 66.8 |
| Avg. Power kW | 1.49 | 1.15 | 0.66 | 0.54 | 0.38 | 0.26 | 0.20 | 0.18 | 0.17 | 0.15 | 0.10 |

Calculate Attenuation =

$$(0.242080) \cdot \sqrt{\text{FMHz}} + (0.000330) \cdot \text{FMHz}$$

(interactive calculator available at http://www.timesmicrowave.com/cable_calculators)

Attenuation:

VSWR=1.0 ; Ambient = +25°C (77°F)

Power: VSWR=1.0; Ambient = +40°C; Inner Conductor = 100°C (212°F); Sea Level; dry air; atmospheric pressure; no solar loading

LMR[®]-240 Flexible Low Loss Communications Coax



Connectors

| Interface | Description | Part Number | Stock Code | VSWR** Freq. (GHz) | Coupling Nut | Inner Contact Attach | Outer Contact Attach | Finish* Body /Pin | Length in (mm) | Width in (mm) | Weight lb (g) |
|-------------|------------------|------------------|------------|-----------------------|--------------|----------------------|----------------------|----------------------|-------------------|------------------|------------------|
| F Male | Straight Plug | TC-240-FM | 3190-924 | <1.25:1 (2.5) | Knurl | Solder | Crimp | N/G | 1.1 (28) | 0.45 (11.4) | 0.014 (6.4) |
| N Male | Straight Plug | EZ-240-NMH-D | 3190-1127 | <1.25:1 (2.5) | Hex/Knurl | Spring Finger | Crimp | A/G | 1.5 (38.1) | 0.78 (19.8) | 0.086 (39.0) |
| N Male | Right Angle | TC-240-NM-RA | 3190-2426 | <1.35:1 (6) | Hex | Solder | Crimp | A/G | 1.3 (32.4) | 1.22 (31.0) | 0.092 (41.7) |
| N Male | Right Angle | TC-240-NMH-RA-D | 3190-2426 | <1.35:1 (6) | Hex/Knurl | Solder | Crimp | A/G | 1.2 (32.4) | 1.22 (31.0) | 0.091 (41.7) |
| N Male | Straight Plug | TC-240-NMH-D | 3190-382* | <1.25:1 (2.5) | Hex/Knurl | Solder | Crimp | N/S | 1.5 (38) | 0.75 (19.1) | 0.086 (39.0) |
| N Male | Straight Plug | TC-240-NMC | 3190-244 | <1.25:1 (2.5) | Knurl | Solder | Clamp | S/G | 1.5 (38) | 0.75 (19.1) | 0.082 (37.2) |
| 1.0/2.3 DIN | Straight Plug | EZ-240-1023M | 3190-2512 | <1.35:1 (2.5) | knurl | Spring Finger | Crimp | N/G | 1.1 (28.5) | 0.33 (8.5) | 0.014 (6.63) |
| N Female | Bulkhead Jack | TC-240-NF-BH | 3190-419 | <1.25:1 (2.5) | NA | Solder | Crimp | A/G | 1.7 (44) | 0.88 (22.2) | 0.115 (52.2) |
| N Female | Panel Mount | TC-240-NF-BHF(A) | 3190-866* | <1.25:1 (2.5) | NA | Solder | Crimp | A/G | 1.7 (44) | 0.88 (22.2) | 0.115 (52.2) |
| BNC Male | Straight Plug | TC-240-BMC | 3190-242 | <1.25:1 (2.5) | Knurl | Solder | Clamp | S/G | 1.7 (43) | 0.56 (14.2) | 0.040 (18.1) |
| BNC Male | Straight Plug | TC-240-BM(A) | 3190-867 | <1.25:1 (2.5) | Knurl | Solder | Crimp | A/G | 1.7 (43) | 0.56 (14.2) | 0.043 (19.5) |
| TNC Male | Straight Plug | EZ-240-TM | 3190-1128 | <1.25:1 (2.5) | Knurl | Spring Finger | Crimp | N/G | 1.4 (34.3) | 0.59 (15.0) | 0.043 (19.5) |
| TNC Male | Straight Plug | TC-240-TM | 3190-275 | <1.25:1 (2.5) | Knurl | Solder | Crimp | N/G | 1.7 (43) | 0.59 (15.0) | 0.043 (19.5) |
| TNC Male | Right Angle | TC-240-TM-RA | 3190-604 | <1.35:1 (2.5) | Knurl | Solder | Crimp | N/G | 1.3 (33) | 0.57 (14.5) | 0.055 (24.9) |
| TNC Male | Reverse Polarity | EZ-240-TM-RP | 3190-970 | <1.25:1 (2.5) | Knurl | Spring Finger | Crimp | A/G | 1.4 (36) | 0.59 (15.0) | 0.043 (19.5) |
| QMA Male | Straight Plug | EZ-240-QM | 3190-1533 | <1.25:1 (6) | Knurl | Spring Finger | Crimp | N/G | 1.2 (30.0) | 0.41 (10.5) | 0.014 (6.35) |
| QMA Male | Right Angle | EZ-240-QM-RA | 3190-1539 | <1.25:1 (<6) | Knurl | Spring Finger | Crimp | N/G | 0.8 (20.3) | 0.65 (16.5) | 0.019 (8.62) |
| SM A Male | Straight Plug | EZ-240-SM | 3190-1530 | <1.25:1 (6) | Hex | Spring Finger | Crimp | N/G | 1.0 (25.4) | 0.32 (8.1) | 0.016 (7.26) |
| SM A Male | Straight Plug | TC-240-SM | 3190-380* | <1.25:1 (10) | Hex | Solder | Crimp | SS/G | 1.0 (25) | 0.32 (8.1) | 0.016 (7.3) |
| SM A Male | Right Angle | TC-240-SM-RA | 3190-381* | <1.35:1 (6) | Hex | Solder | Crimp | SS/G | 0.8 (20) | 0.65 (16.5) | 0.019 (8.6) |
| SM A Male | Reverse Polarity | TC-240-SM-RP | 3190-326 | <1.25:1 (2.5) | Hex | Solder | Crimp | SS/G | 1.0 (25) | 0.32 (8.1) | 0.016 (7.3) |
| SMA Female | Bulkhead Jack | TC-240-SF-BH | 3190-824* | <1.25:1 (2.5) | NA | Solder | Crimp | SS/G | 1.1 (29) | 0.31 (7.9) | 0.019 (8.6) |
| Mini-UHF | Straight Plug | TC-240-MUHF | 3190-445 | <1.25:1 (2.5) | Knurl | Solder | Crimp | N/G | 1.1 (28) | 0.45 (11.4) | 0.014 (6.4) |

* Finish metals: N=Nickel, S=Silver, G=Gold, SS=Stainless Steel, A=Alloy **VSWR spec based on 3 foot cable with a connector pair *Available in bulk pack



Hardware Accessories

| Type | Part Number | Stock Code | Description |
|------------|-------------|------------|----------------------------|
| Ground Kit | GK-S240TT | GK-S240TT | Standard Ground Kit (each) |



Install Tools

| Type | Part Number | Stock Code | Description |
|-------------------|--------------------|------------|---|
| Crimp Tool | CT-240/200/195/100 | 3190-667 | Crimp tool for LMR-100, 195, 200 and 240 connectors |
| Strip Tool | CST-240 | 3192-070 | Strip tool |
| Deburr Tool | DBT-U | 3192-001 | Removes center conductor rough edges |
| Cutting Tool | CCT-01 | 3190-1544 | Cable end flush cut tool |
| Replacement Blade | RB-01 | 3190-1609 | Replacement blade for cutting tool |
| Replacement | RB-CST | 3192-086 | Replacement blade kit for all CST strip tools |