



Reverse Polarity SMA Male Right Angle Connector Crimp/
Solder Attachment for RG58, RG141, PE-C195, PE-P195

RF Connectors Technical Data Sheet

PE45012

Configuration

- SMA Male Reverse Polarity Connector
- 50 Ohms
- Right Angle Body Geometry
- RG58, RG141, PE-C195, PE-P195 Interface Type
- Crimp/Solder Attachment
- 5/16 in Hex

Mechanical Specifications

Size

Length	0.63 in [16 mm]
Width/Dia.	0.312 in [7.92 mm]
Height	0.79 in [20.07 mm]
Weight	0.013 lbs [5.9 g]
Mating Torque	5 in-lbs [0.57 Nm]

Material Specifications

Description	Material	Plating
Contact	Beryllium Copper	Gold
Insulation	PTFE	
Body	Brass	Nickel
Coupling Nut	Brass	Nickel

Compliance Certifications (visit www.Pasternack.com for current document)
RoHS Compliant

Click the following link (or enter part number in "SEARCH" on website) to obtain additional part information including price, inventory and certifications: [Reverse Polarity SMA Male Right Angle Connector Crimp/Solder Attachment for RG58, RG141, PE-C195, PE-P195 PE45012](#)



Reverse Polarity SMA Male Right Angle Connector Crimp/ Solder Attachment for RG58, RG141, PE-C195, PE-P195

RF Connectors Technical Data Sheet

PE45012

Plotted and Other Data

Notes:

Reverse Polarity SMA Male Right Angle Connector Crimp/Solder Attachment for RG58, RG141, PE-C195, PE-P195 from Pasternack Enterprises has same day shipment for domestic and International orders. Our RF, microwave and millimeter wave products maintain a 99% availability and are part of the broadest selection in the industry.

Click the following link (or enter part number in "SEARCH" on website) to obtain additional part information including price, inventory and certifications: [Reverse Polarity SMA Male Right Angle Connector Crimp/Solder Attachment for RG58, RG141, PE-C195, PE-P195 PE45012](http://www.pasternack.com/sma-male-reverse-polarity-rg58-rg141-pe-c195-pe-p195-connector-pe45012-p.aspx)

URL: <http://www.pasternack.com/sma-male-reverse-polarity-rg58-rg141-pe-c195-pe-p195-connector-pe45012-p.aspx>

The information contained in this document is accurate to the best of our knowledge and representative of the part described herein. It may be necessary to make modifications to the part and/or the documentation of the part, in order to implement improvements. Pasternack reserves the right to make such changes as required. Unless otherwise stated, all specifications are nominal. Pasternack does not make any representation or warranty regarding the suitability of the part described herein for any particular purpose, and Pasternack does not assume any liability arising out of the use of any part or documentation.

PE45012 CAD Drawing

Reverse Polarity SMA Male Right Angle Connector Crimp/Solder
Attachment for RG58, RG141, PE-C195, PE-P195

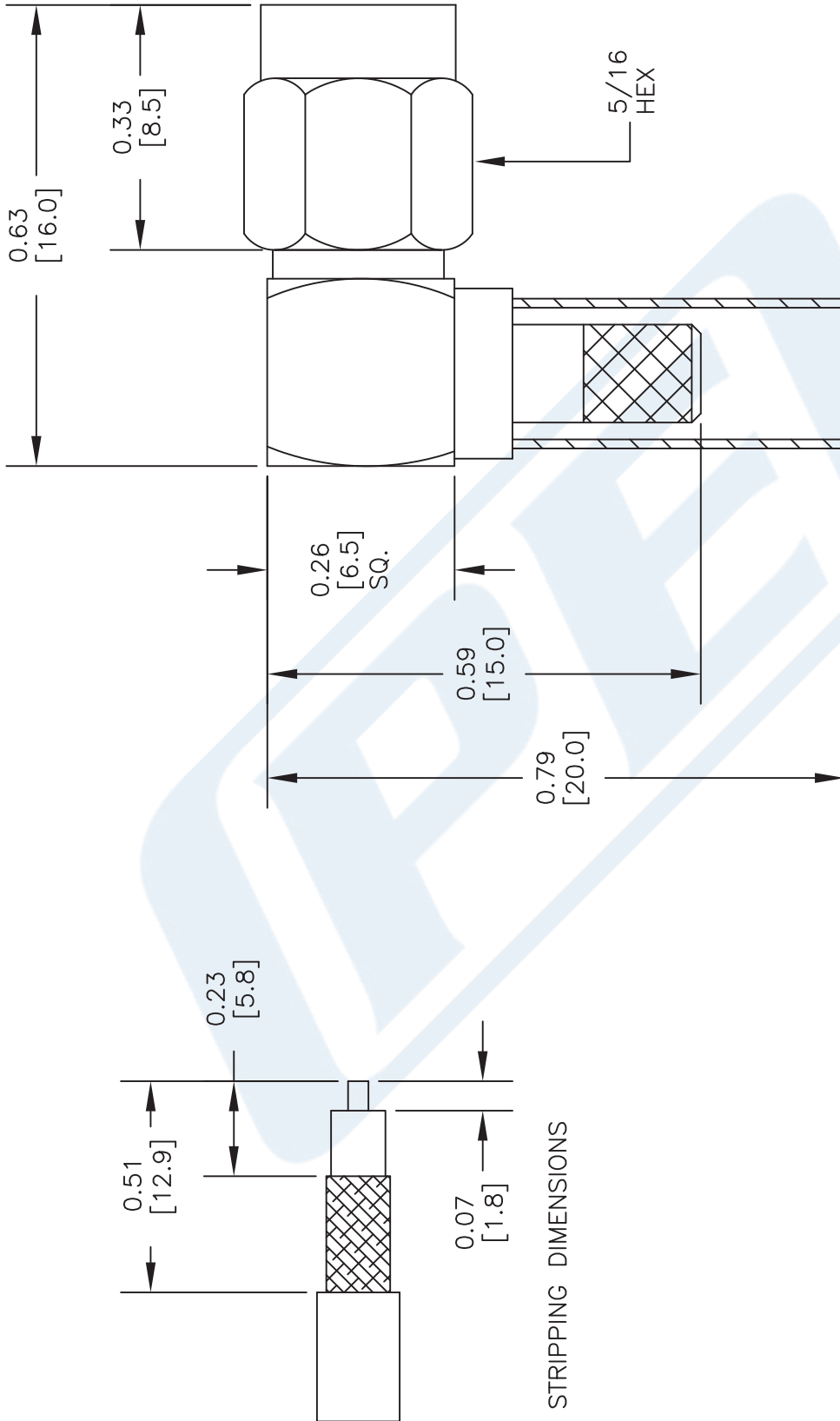

DWG TITLE

PE45012

NOTES:
1. UNLESS OTHERWISE SPECIFIED ALL DIMENSIONS ARE NOMINAL.
2. ALL SPECIFICATIONS ARE SUBJECT TO CHANGE WITHOUT NOTICE AT ANY TIME.
3. DIMENSIONS ARE IN INCHES [mm].
4. FITS MIL-C-17 AND EQUIVALENT CABLES.

FSCM NO. 53919

CAD FILE 110215

SCALE N/A

SIZE A

2233



THE ENGINEER'S RF SOURCE
Pasternack Enterprises, Inc.
P.O. Box 16759 | Irvine | CA | 92623

Phone: (949) 261-1920 | Fax: (949) 261-7451

Website: www.pasternack.com | E-Mail: sales@pasternack.com

N Male Connector Crimp/Solder
Attachment for LMR-195, PE-C195



TC-195-NMH-X



Times Microwave Systems Connector Specification

Configuration

- N Male Connector
- MIL-STD-348
- 50 Ohms
- Straight Body Geometry
- Connector Interface Types: LMR-195, PE-C195
- 13/16 Inch Hex

Features

- Max. Operating Frequency 8 GHz
- Good VSWR of 1.3:1
- Gold Plated Brass Contact
- 50 µin minimum contact plating

Applications

- General Purpose Test
- Custom Cable Assemblies

Description

Pasternack's TC-195-NMH-X type N , N, Standard, Connector is part of our full line of RF components available for same-day shipping. Our type N male connector operates up to a maximum frequency of 8 GHz and offers good VSWR of 1.3:1.

Our type N male connector TC-195-NMH-X datasheet specifications and drawing with dimensions are shown below in this PDF. Pasternack's broad catalog of RF, microwave and millimeter wave connectors allows designers to configure and customize their signal connections however they like. Whether the need is to provide an I/O for a board design, or simply create a custom cable assembly configuration, Pasternack has the right connector for the job. Pasternack can also expertly build your custom cable assemblies for you and ship same-day.

Electrical Specifications

Description	Minimum	Typical	Maximum	Units
Frequency Range	DC		8	GHz
VSWR			1.3:1	
Insertion Loss			0.28	dB
Dielectric Withstanding Voltage (AC)			1,000	Vrms
Insulation Resistance	5,000			MOhms
Impedance		50		Ohms

Mechanical Specifications

Size

- Length 1.4 in [35.56 mm]
- Width 0.81 in [20.57 mm]
- Height 0 in [0 mm]
- Weight 0.084 lbs [38.1 g]
- Mating Cycles 500 Cycles
- Mating Torque 9 to 14 in-lbs [[1.02 to 1.58 Nm]]

N Male Connector Crimp/Solder Attachment for LMR-195, PE-C195



TC-195-NMH-X

Material Specifications

Description	Material	Plating
Contact	Brass	Gold 50 µin minimum
Insulation	Teflon	
Body	Brass	Tri-Metal
Coupling Nut	Brass	Tri-Metal

Environmental Specifications

Temperature

Operating Range

-40 to +125 deg C

Shock

MIL-STD 202G, Meth. 213, Cond. I

Vibration

MIL-STD 202G, Meth. 204, Cond. B

Thermal Shock

MIL-STD-202G, Meth. 107, Cond. B

Compliance Certifications (see [product page](#) for current document)

Plotted and Other Data

Notes:

N Male Connector Crimp/Solder Attachment for LMR-195, PE-C195 from Pasternack Enterprises has same day shipment for domestic and International orders. Our RF, microwave and millimeter wave products maintain a 99.4% availability and are part of the broadest selection in the industry.

Click the following link (or enter part number in "SEARCH" on website) to obtain additional part information including price, inventory and certifications: [N Male Connector Crimp/Solder Attachment for LMR-195, PE-C195 TC-195-NMH-X](#)

URL: <https://www.pasternack.com/n-male-lmr-195-pe-c195-connector-tc-195-nmh-x-p.aspx>

The information contained within this document is accurate to the best of our knowledge and representative of the part described herein. It may be necessary to make modifications to the part and/or the documentation of the part in order to implement improvements. Pasternack Enterprises reserves the right to make such changes as required. Unless otherwise stated, all specifications are nominal. Pasternack Enterprises does not make any representation or warranty regarding the suitability of the part described herein for any particular purpose, and Pasternack Enterprises does not assume liability arising out of the use of any part or document.

TC-195-NMH-X CAD Drawing

N Male Connector Crimp/Solder Attachment for LMR-195, PE-C195

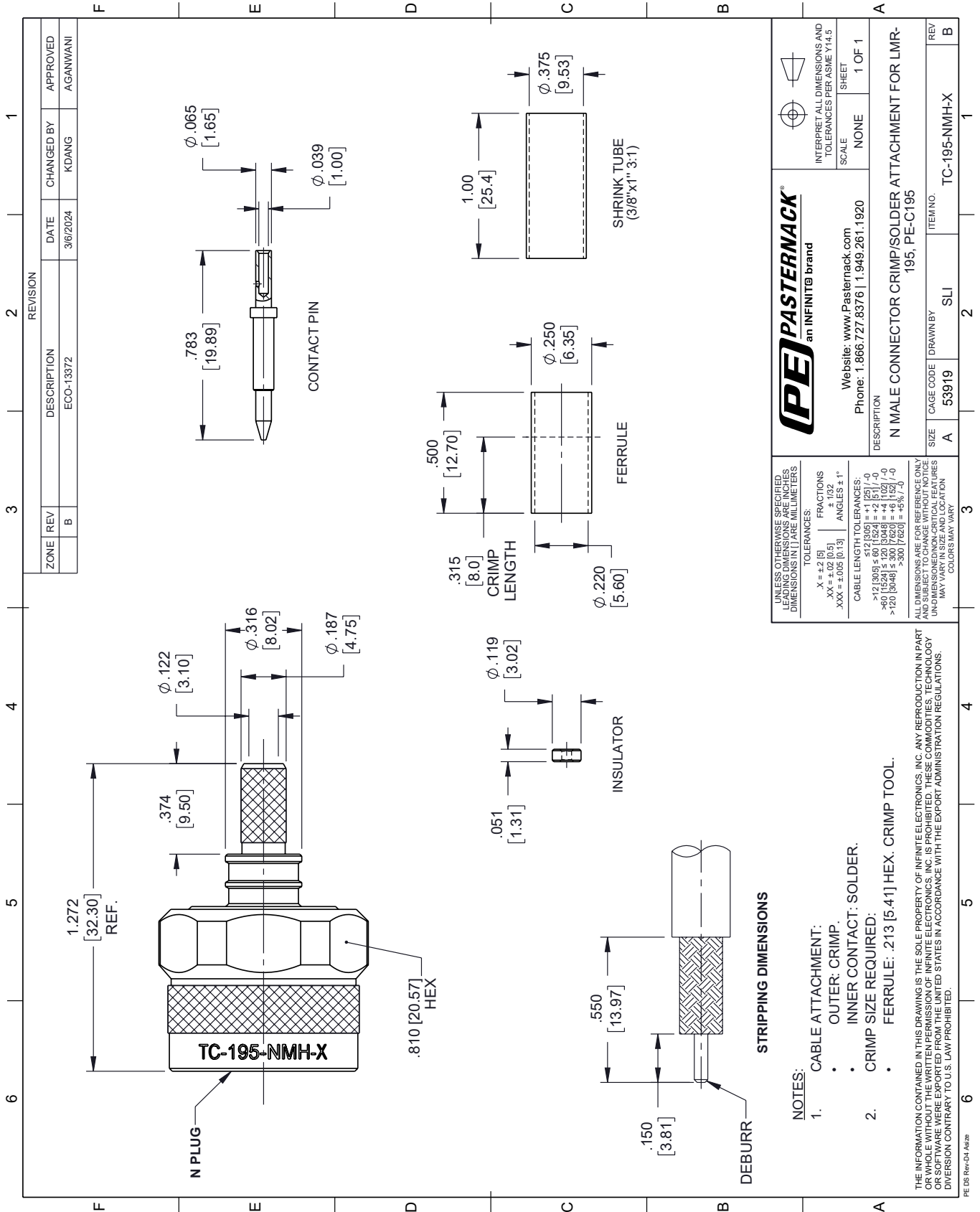

REVISION		DATE	CHANGED BY	APPROVED
ZONE	REV	DESCRIPTION		
	B	ECO-13372	KDANG	AGANWANI

PE PASTERNAK
an INFINITE brand

Website: www.Pasternack.com
Phone: 1.866.727.8376 | 1.949.261.1920

INTERPRET ALL DIMENSIONS AND TOLERANCES PER ASME Y14.5
SCALE: NONE
SHEET: 1 OF 1

DESCRIPTION: N MALE CONNECTOR CRIMP/SOLDER ATTACHMENT FOR LMR-195, PE-C195

SIZE	CAGE CODE	DRAWN BY	ITEM NO.
A	53919	SLI	TC-195-NMH-X

UNLESS OTHERWISE SPECIFIED, LEADING DIMENSIONS ARE IN INCHES, DIMENSIONS IN [] ARE MILLIMETERS

TOLERANCES:
 .X = ±.2 [5]
 .XX = ±.02 [0.5]
 .XXX = ±.005 [0.13]

FRACTIONS: ±.132
 ANGLES: ±1°

CABLE LENGTH TOLERANCES:
 <12 [305] ≤ 60 [1524] = +1 [25] / -0
 >60 [1524] ≤ 120 [3048] = +4 [102] / -0
 >120 [3048] ≤ 300 [7620] = +5% / -0

ALL DIMENSIONS ARE FOR REFERENCE ONLY. UNDIMENSIONED/NON-CRITICAL FEATURES MAY VARY IN SIZE AND LOCATION. COLORS MAY VARY.

- NOTES:**
- CABLE ATTACHMENT:
 • OUTER: CRIMP.
 • INNER CONTACT: SOLDER.
 - CRIMP SIZE REQUIRED:
 • FERRULE: .213 [5.41] HEX. CRIMP TOOL.

THE INFORMATION CONTAINED IN THIS DRAWING IS THE SOLE PROPERTY OF INFINITE ELECTRONICS, INC. ANY REPRODUCTION IN PART OR WHOLE WITHOUT THE WRITTEN PERMISSION OF INFINITE ELECTRONICS, INC. IS PROHIBITED. THESE COMMODITIES, TECHNOLOGY OR SOFTWARE ARE EXPORTED FROM THE UNITED STATES IN ACCORDANCE WITH THE EXPORT ADMINISTRATION REGULATIONS. DIVISION CONTRARY TO U.S. LAW PROHIBITED.

PE DS Rev-04 Add2



Low Loss Flexible PE-P195 Coax Cable Triple Shielded with Tan FEP Jacket

RF Cables Technical Data Sheet

PE-P195

Configuration

- Low Loss Flexible Cable
- 3 Shield(s)

Electrical Specifications

Description	Minimum	Typical	Maximum	Units
Frequency Range	DC		22	GHz
Impedance		50		Ohms
Velocity of Propagation		70		%
Operating Voltage (AC)			1,900	Vrms
Dielectric Withstanding Voltage (AC)			5,000	Vrms
Nominal Capacitance		29 [95.14]		pF/ft [pF/m]

Performance by Frequency Band

Description	F1	F2	F3	F4	F5	Units
Frequency	0.1	0.5	1	5	10	GHz
Attenuation, Typ	3.9	8.8	12.5	31.5	45	dB/100ft
	12.8	28.87	41.01	103.35	147.64	dB/100m

Description	F6	F7	F8	F9	F10	Units
Frequency	15	18	20	22		GHz
Attenuation, Typ	58	65	69	73		dB/100ft
	190.29	213.25	226.38	239.5		dB/100m

Mechanical Specifications

Diameter	0.195 in [4.95 mm]
Weight	0.038 lbs/ft [0.06 Kg/m]
Min. Bend Radius (Repeated)	1 in [25.4 mm]

Click the following link (or enter part number in "SEARCH" on website) to obtain additional part information including price, inventory and certifications: [Low Loss Flexible PE-P195 Coax Cable Triple Shielded with Tan FEP Jacket PE-P195](#)



Low Loss Flexible PE-P195 Coax Cable Triple Shielded with Tan FEP Jacket

RF Cables Technical Data Sheet

PE-P195

Construction Specifications

Description	Material and Plating	Diameter
Inner Conductor	Copper Clad Steel, Silver, 1 Strands	0.037 in [0.94 mm]
Conductor Type	Solid	
Dielectric	PTFE	0.116 in [2.95 mm]
First Shield	Silver Plated Copper Braid 96% coverage	0.126 in [3.2 mm]
Second Shield	Aluminum Tape	0.132 in [3.35 mm]
Third Shield	Silver Plated Copper Braid 96% coverage	0.155 in [3.94 mm]
Jacket	FEP, Tan	0.195 in [4.95 mm]

Environmental Specifications

Temperature

Operating Range -55 to +200 deg C

Compliance Certifications (see [product page](#) for current document)

Plotted and Other Data

Notes:

Low Loss Flexible PE-P195 Coax Cable Triple Shielded with Tan FEP Jacket from Pasternack Enterprises has same day shipment for domestic and International orders. Our RF, microwave and millimeter wave products maintain a 99.4% availability and are part of the broadest selection in the industry.

Click the following link (or enter part number in "SEARCH" on website) to obtain additional part information including price, inventory and certifications: [Low Loss Flexible PE-P195 Coax Cable Triple Shielded with Tan FEP Jacket PE-P195](#)

URL: <https://www.pasternack.com/precision-0.195-rg142-solid-center-conductor-52-ohm-coax-cable-fep-jacket-pe-p195-p.aspx>

The information contained in this document is accurate to the best of our knowledge and representative of the part described herein. It may be necessary to make modifications to the part and/or the documentation of the part, in order to implement improvements. Pasternack reserves the right to make such changes as required. Unless otherwise stated, all specifications are nominal. Pasternack does not make any representation or warranty regarding the suitability of the part described herein for any particular purpose, and Pasternack does not assume any liability arising out of the use of any part or documentation.

PE-P195 CAD Drawing

Low Loss Flexible PE-P195 Coax Cable Triple Shielded with Tan FEP Jacket

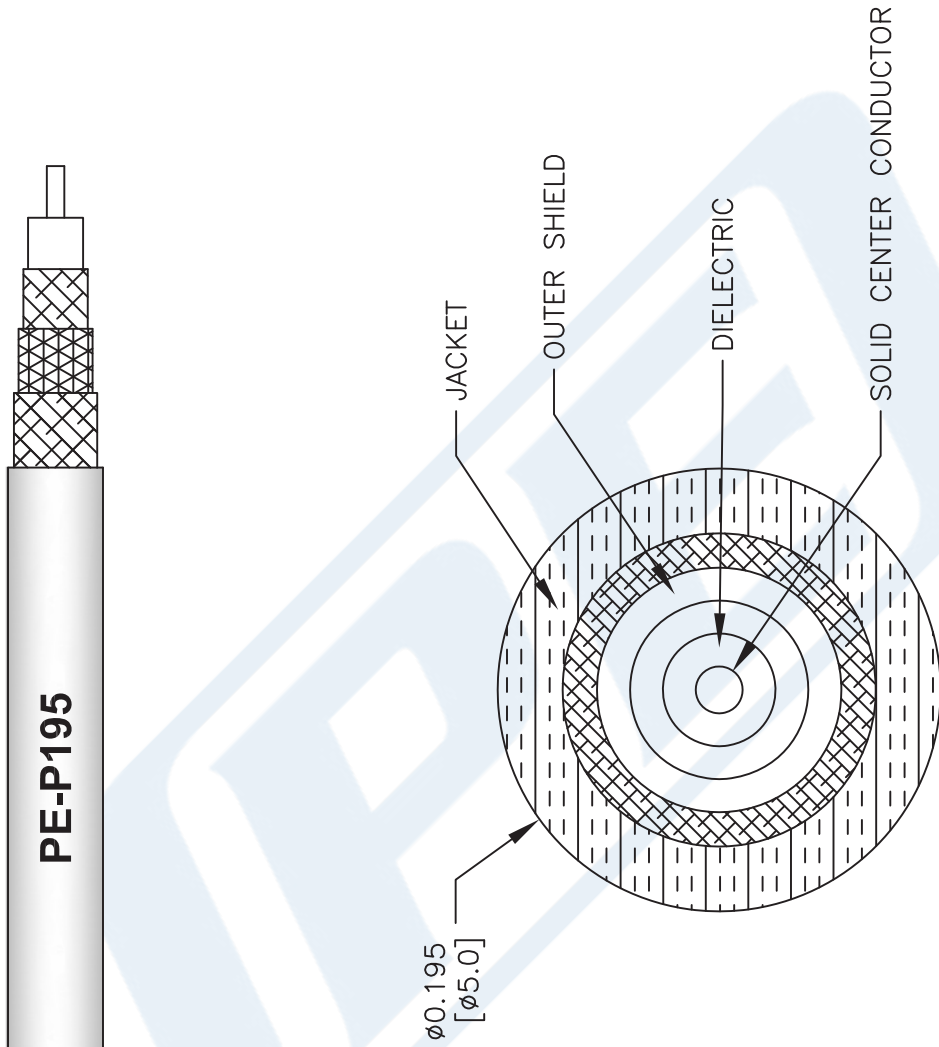

NOTES:
 1. UNLESS OTHERWISE SPECIFIED ALL DIMENSIONS ARE NOMINAL.
 2. ALL SPECIFICATIONS ARE SUBJECT TO CHANGE WITHOUT NOTICE AT ANY TIME.
 3. DIMENSIONS ARE IN INCHES [mm].

DWG TITLE		FSCM NO. 53919	
PE-P195		CAD FILE	SCALE N/A
		111716	SIZE A
			41742

PE PASTERNAK
 THE ENGINEER'S RF SOURCE
 Pasternack Enterprises, Inc.
 P.O. Box 16759 | Irvine | CA | 92623
 Phone: (949) 261-1920 | Fax: (949) 261-7451
 Website: www.pasternack.com | E-Mail: sales@pasternack.com