



## BNC Male Connector Crimp/Solder Attachment for LMR-400, PE-C400

### RF Connectors Technical Data Sheet



TC-400-BM-X

### Times Microwave Systems Connector Specification

#### Configuration

- BNC Male Connector
- 50 Ohms
- Straight Body Geometry
- Connector Interface Types: LMR-400, PE-C400

#### Features

- Max. Operating Frequency 6 GHz
- Good VSWR of 1.3:1
- Gold Plated Brass Contact
- 50 microns contact plating

#### Applications

- General Purpose Test
- Custom Cable Assemblies

#### Description

Pasternack's TC-400-BM-X BNC male connector with crimp/solder attachment for LMR-400 and PE-C400 is part of our full line of RF components available for same-day shipping. Our BNC male connector operates up to a maximum frequency of 6 GHz and offers good VSWR of 1.3:1.

Our BNC male connector TC-400-BM-X datasheet specifications and drawing with dimensions are shown below in this PDF. Pasternack's broad catalog of RF, microwave and millimeter wave connectors allows designers to configure and customize their signal connections however they like. Whether the need is to provide an I/O for a board design, or simply create a custom cable assembly configuration, Pasternack has the right connector for the job. Pasternack can also expertly build your custom cable assemblies for you and ship same-day.

#### Electrical Specifications

Description	Minimum	Typical	Maximum	Units
Frequency Range	DC		6	GHz
VSWR			1.3:1	
Insertion Loss			0.25	dB
Dielectric Withstanding Voltage (AC)			1,500	Vrms
Insulation Resistance	5,000			MOhms

#### Mechanical Specifications

##### Size

Length	1.91 in [48.51 mm]
Width/Dia.	0.55 in [13.97 mm]
Weight	0.083 lbs [37.65 g]
Mating Cycles	500 Cycles

Click the following link (or enter part number in "SEARCH" on website) to obtain additional part information including price, inventory and certifications: [BNC Male Connector Crimp/Solder Attachment for LMR-400, PE-C400 TC-400-BM-X](#)



## BNC Male Connector Crimp/Solder Attachment for LMR-400, PE-C400

### RF Connectors Technical Data Sheet



TC-400-BM-X

#### Material Specifications

Description	Material	Plating
Contact	Brass	Gold 50 microns
Insulation	PTFE	
Body	Brass	Tri-Metal 80 microns
Coupling Nut	Brass	Tri-Metal 80 microns
Gasket	Silicone	
Crimp Sleeve	Brass	Tri-Metal 80 microns

#### Environmental Specifications

##### Temperature

Operating Range

-55 to +125 deg C

Shock

MIL-STD 202G, Meth.213, Cond G

Vibration

MIL-STD 202G, Meth.204, Cond B

Thermal Shock

MIL-STD 202G, Meth.107, Cond B

#### Compliance Certifications (see [product page](#) for current document)

#### Plotted and Other Data

Notes:

BNC Male Connector Crimp/Solder Attachment for LMR-400, PE-C400 from Pasternack Enterprises has same day shipment for domestic and International orders. Our RF, microwave and millimeter wave products maintain a 99.4% availability and are part of the broadest selection in the industry.

Click the following link (or enter part number in "SEARCH" on website) to obtain additional part information including price, inventory and certifications: [BNC Male Connector Crimp/Solder Attachment for LMR-400, PE-C400 TC-400-BM-X](#)

URL: <https://www.pasternack.com/bnc-male-lmr-400-pe-c400-connector-tc-400-bm-x-p.aspx>

The information contained in this document is accurate to the best of our knowledge and representative of the part described herein. It may be necessary to make modifications to the part and/or the documentation of the part, in order to implement improvements. Pasternack reserves the right to make such changes as required. Unless otherwise stated, all specifications are nominal. Pasternack does not make any representation or warranty regarding the suitability of the part described herein for any particular purpose, and Pasternack does not assume any liability arising out of the use of any part or documentation.

REVISIONS			
REV.	DESCRIPTION	DATE	APPROVED
AA	INITIAL RELEASE	12/09/19	SELLIS

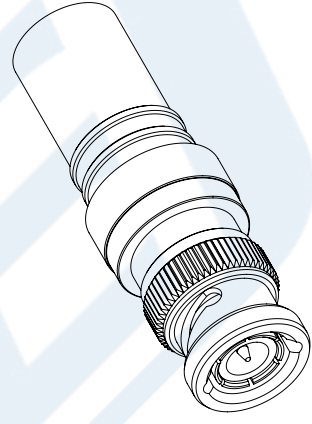
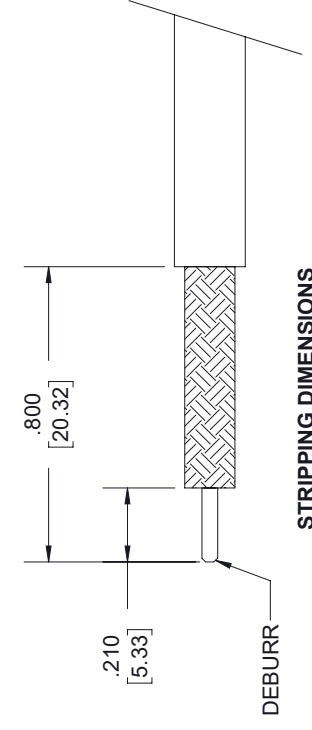
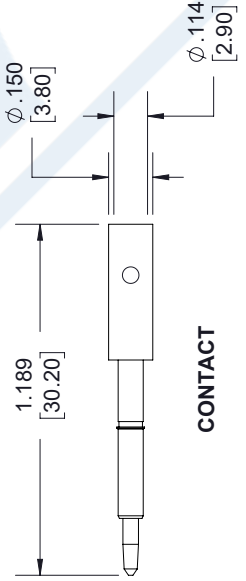
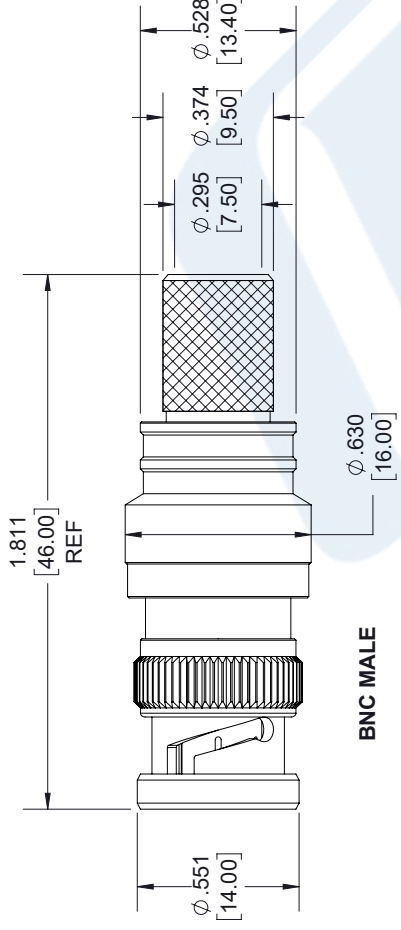
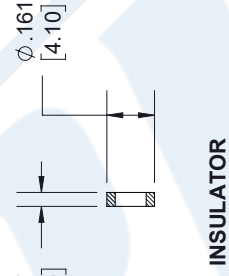
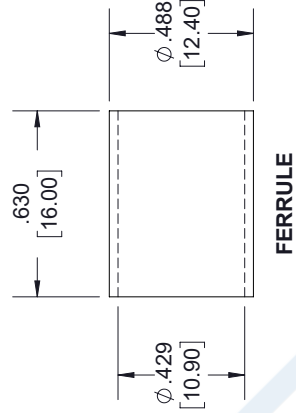
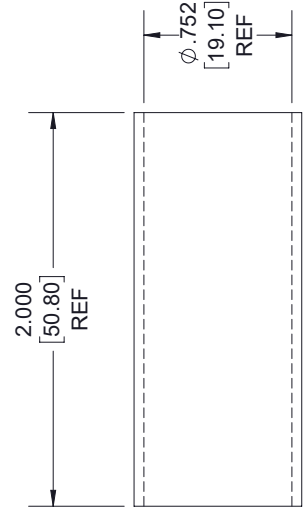

THIRD-ANGLE PROJECTION

THE INFORMATION AND DESIGN IN THIS DOCUMENT IS THE PROPERTY OF PASTERNAK CORPORATION. ALL RIGHTS RESERVED.

SHEET 1 OF 1

SCALE N/A

REV A

---

**PE PASTERNAK**  
an INFINIT® brand

Pasternack Enterprises, Inc.  
P. O. Box 16759, Irvine, CA 92623.  
Phone: 1.949.261.1920 | 1.866.727.8376  
Fax: 1.949.261.7451  
Website: www.pasternack.com  
E-mail: sales@pasternack.com

UNLESS OTHERWISE SPECIFIED LEADING DIMENSIONS ARE INCHES DIMENSIONS IN [ ] ARE MILLIMETERS

TOLERANCES:

.X = ±.2	[5.08]	FRACTIONS
.XX = ±.02	[.51]	±.1/32
.XXX = ±.005	[.13]	ANGLES ± 1°

CABLE LENGTH (L) TOLERANCES:

L ≤ 12	[305]	= +1 [25] / -0
12 [305] < L ≤ 60	[1524]	= +2 [51] / -0
60 [1524] < L ≤ 120	[3048]	= +4 [102] / -0
120 [3048] < L ≤ 300	[7620]	= +6 [152] / -0
300 [7620] < L		= +5%L / -0

ALL DIMENSIONS SHOWN ARE FOR REFERENCE ONLY.

---

SIZE A CAGE CODE 53919 DRAWN BY K.DANG PART NUMBER TC-400-BM-X

- NOTES:
- CABLE ATTACHMENT:
    - OUTER: CRIMP.
    - INNER: SOLDER.
  - CRIMP SIZE REQUIRED:
    - FERRULE: .429 [10.90] HEX. CRIMP TOOL.
    - CONTACT: SOLDER.

THESE COMMODITIES, TECHNOLOGY OR SOFTWARE WERE EXPORTED FROM THE UNITED STATES IN ACCORDANCE WITH THE EXPORT ADMINISTRATION REGULATIONS. DIVERSION CONTRARY TO U.S. LAW PROHIBITED.



## Standard N Female Connector Crimp/Solder Attachment for LMR-400, PE-C400

### RF Connectors Technical Data Sheet



TC-400-NF-X

## Times Microwave Systems Connector Specification

### Configuration

- N Female Connector
- MIL-STD-348
- 50 Ohms
- Straight Body Geometry
- Connector Interface Types: LMR-400, PE-C400

### Features

- Max. Operating Frequency 6 GHz
- Good VSWR of 1.3:1
- Gold Plated Copper Contact

### Applications

- General Purpose Test
- Custom Cable Assemblies

### Description

Pasternack's TC-400-NF-X type N female connector with crimp/solder attachment for LMR-400 and PE-C400 is part of our full line of RF components available for same-day shipping. Our type N female connector operates up to a maximum frequency of 6 GHz and offers good VSWR of 1.3:1.

Our type N female connector TC-400-NF-X datasheet specifications and drawing with dimensions are shown below in this PDF. Pasternack's broad catalog of RF, microwave and millimeter wave connectors allows designers to configure and customize their signal connections however they like. Whether the need is to provide an I/O for a board design, or simply create a custom cable assembly configuration, Pasternack has the right connector for the job. Pasternack can also expertly build your custom cable assemblies for you and ship same-day.

### Electrical Specifications

Description	Minimum	Typical	Maximum	Units
Frequency Range	DC		6	GHz
VSWR			1.3:1	
Insertion Loss			0.1	dB
Operating Voltage (AC)			1,500	Vrms
Inner Conductor DC Resistance			0.8	mOhms
Outer Conductor DC Resistance			0.4	mOhms
Insulation Resistance	5,000			MOhms

### Mechanical Specifications

#### Size

Length	1.56 in [39.62 mm]
Width/Dia.	0.63 in [16.00 mm]

Click the following link (or enter part number in "SEARCH" on website) to obtain additional part information including price, inventory and certifications: [Standard N Female Connector Crimp/Solder Attachment for LMR-400, PE-C400 TC-400-NF-X](#)



# Standard N Female Connector Crimp/Solder Attachment for LMR-400, PE-C400

## RF Connectors Technical Data Sheet

Weight 0.088 lbs [39.92 g]

### Material Specifications

Description	Material	Plating
Contact	Copper	Gold
Insulation	PTFE	
Outer Conductor	Brass	Tri-Metal
Body	Brass	Tri-Metal

### Environmental Specifications

#### Temperature

Operating Range -55 to +155 deg C

Shock US MIL-STD 202, Meth. 213, Cond. I

Vibration US MIL-STD 202, Meth. 204, Cond. B

Thermal Shock US MIL-STD 202, Meth. 107, Cond. B

### Compliance Certifications (see [product page](#) for current document)

### Plotted and Other Data

Notes:

Standard N Female Connector Crimp/Solder Attachment for LMR-400, PE-C400 from Pasternack Enterprises has same day shipment for domestic and International orders. Our RF, microwave and millimeter wave products maintain a 99.4% availability and are part of the broadest selection in the industry.

Click the following link (or enter part number in "SEARCH" on website) to obtain additional part information including price, inventory and certifications: [Standard N Female Connector Crimp/Solder Attachment for LMR-400, PE-C400 TC-400-NF-X](#)

URL: <https://www.pasternack.com/n-female-lmr-400-pe-c400-connector-tc-400-nf-x-p.aspx>

The information contained in this document is accurate to the best of our knowledge and representative of the part described herein. It may be necessary to make modifications to the part and/or the documentation of the part, in order to implement improvements. Pasternack reserves the right to make such changes as required. Unless otherwise stated, all specifications are nominal. Pasternack does not make any representation or warranty regarding the suitability of the part described herein for any particular purpose, and Pasternack does not assume any liability arising out of the use of any part or documentation.

REVISIONS		
REV.	DESCRIPTION	DATE
A	INITIAL RELEASE	7/19/21
		APPROVED SRAUTUS

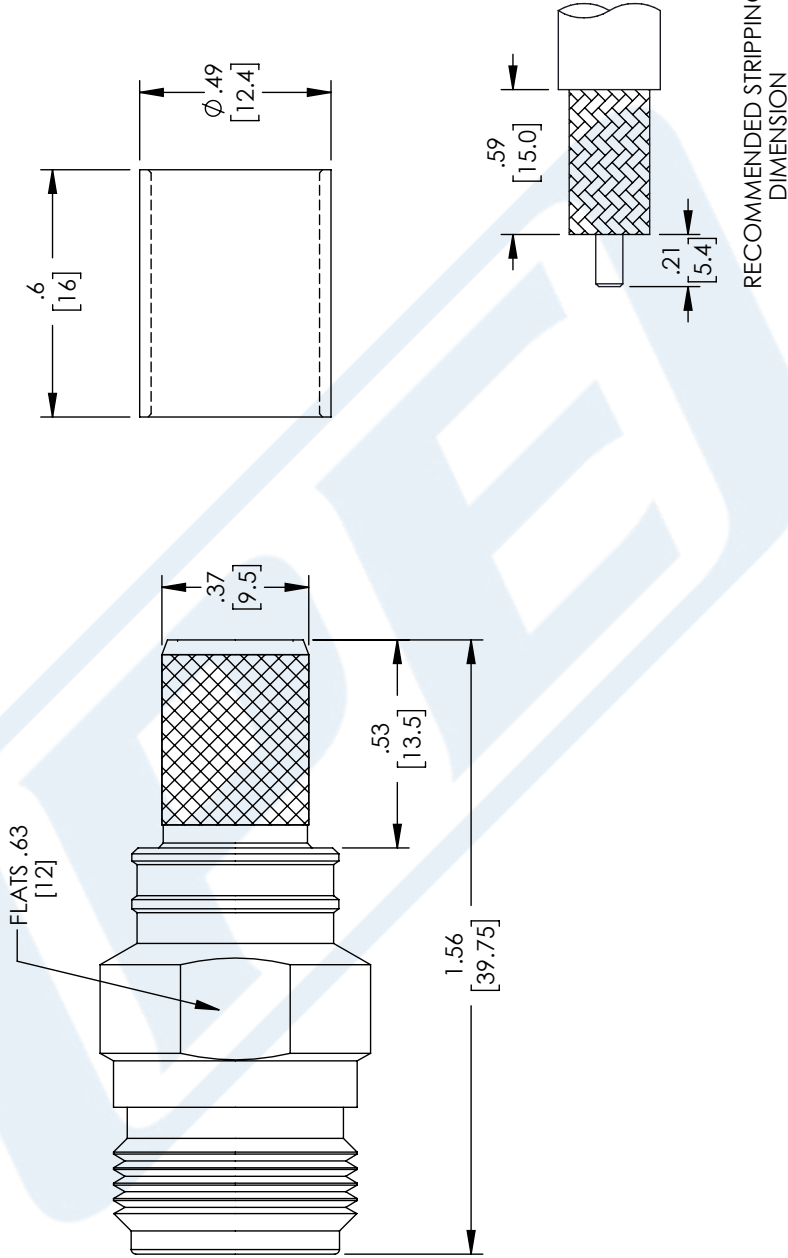

<p>UNLESS OTHERWISE SPECIFIED LEADING DIMENSIONS ARE INCHES DIMENSIONS IN [ ] ARE MILLIMETERS</p> <p><b>TOLERANCES:</b></p> <p>.X = ±.2 [5.08]    FRACTIONS ± 1/32          .XX = ±.02 [ .51]    ANGLES ± 1°          .XXX = ±.005 [ .13]</p> <p><b>CABLE LENGTH (L), TOLERANCES:</b></p> <p>L ≤ 12 [305] = +1 [25] / -0          12 [305] &lt; L ≤ 60 [1524] = +2 [51] / -0          60 [1524] &lt; L ≤ 120 [3048] = +4 [102] / -0          120 [3048] &lt; L ≤ 300 [7620] = +6 [152] / -0          300 [7620] &lt; L = +5% / -0</p> <p>ALL DIMENSIONS SHOWN ARE FOR REFERENCE ONLY.</p>	<p><b>THIRD-ANGLE PROJECTION</b></p>  <p>THE INFORMATION AND DESIGN IN THIS DOCUMENT IS THE PROPERTY OF PASTERNAK CORPORATION ALL RIGHTS RESERVED.</p> <p>SHEET 1 OF 1</p> <p>SCALE N/A</p>	<p><b>PE PASTERNAK</b> an INFINITI® brand</p> <p>Pasternack Enterprises, Inc.          P. O. Box 16759, Irvine, CA 92623.          Phone: 1.949.261.1920   1.866.727.8376          Fax: 1.949.261.7451          Website: www.pasternack.com          E-mail: sales@pasternack.com</p> <p>SIZE A    CAGE CODE 53919    DRAWN BY DMAY    ITEM NO. TC-400-NF-X    REV A</p>
---	--	--

THESE COMMODITIES, TECHNOLOGY OR SOFTWARE WERE EXPORTED FROM THE UNITED STATES IN ACCORDANCE WITH THE EXPORT ADMINISTRATION REGULATIONS. DIVERSION CONTRARY TO U.S. LAW PROHIBITED.

## LMR-<sup>®</sup>400-UF UltraFlex Communications Coax

### Ideal for...

- Drop-in replacement for RG-8/9913 Air-Dielectric type Cable
- Jumper Assemblies in Wireless Communications Systems
- Short Antenna Feeder runs
- Any application that requires periodic/repeated flexing



• **LMR<sup>®</sup> - UltraFlex** has a stranded center conductor and rubber outer jacket designed for multiple bending/flexing cycles. It is used for both indoor and outdoor applications.

• **Flexibility** and bendability are hallmarks of the LMR-400-UF cable design. The flexible outer conductor enables the tightest bend radius available for any cable of similar size and performance.

• **Low Loss** is another hallmark feature of LMR-400-UF. Size for size LMR has the lowest loss of any flexible cable and comparable loss to semirigid hard-line cables.

• **RF Shielding** is 50 dB greater than typical single shielded coax (40 dB). The multi-ply bonded foil outer conductor is rated conservatively at > 90 dB (i.e. >180 dB between two adjacent cables).

• **Weatherability:** LMR-400-UF cables are designed for outdoor exposure and have a life expectancy in excess of 10 years.

• **Connectors:** A wide variety of connectors are available for LMR-400-UF cable, including all common interface types, reverse polarity, and solder-on center pins. Most LMR connectors employ crimp outer attachment using standard hex crimp sizes.

• **Cable Assemblies:** All LMR-400-UF cable types are available as pre-terminated cable assemblies. Refer to the section on FlexTech for further details.

Part Description				
Part Number	Application	Jacket	Color	Stock Code
LMR-400-UF	Indoor/Outdoor	TPE	Black	54040

Construction Specifications				
Description	Material	In.	(mm)	
Inner Conductor	Stranded BC	0.108	(2.74)	
Dielectric	Foam Polyethylene	0.285	(7.24)	
Outer Conductor	Aluminum Tape	0.291	(7.39)	
Overall Braid	Tinned Copper	0.320	(8.13)	
Jacket	Black Thermoplastic Elastomer	0.405	(10.29)	

# LMR<sup>®</sup>-400-UF UltraFlex Communications Coax



## Connectors

Interface	Description	Part Number	Stock Code	VSWR** Freq. (GHz)	Coupling Nut	Inner Contact Attach	Outer Contact Attach	Finish* Body /Pin	Length in (mm)	Width in (mm)	Weight lb (g)
7-16 DIN Female	Straight Jack	TC-400-716-FC	3190-376	<1.25:1 (2.5)	NA	Solder	Clamp	S/S	1.6 (41)	1.13 (28.7)	0.281 (127.5)
7-16 DIN Male	Straight Plug	TC-400-716-MC	3190-279	<1.25:1 (2.5)	Hex	Solder	Clamp	S/S	1.4 (36)	1.40 (35.6)	0.268 (121.6)
BNC Male	Straight Plug	TC-400-BM	3190-318	<1.25:1 (2.5)	Knurl	Solder	Crimp	N/S	1.7 (43)	0.56 (14.2)	0.063 (28.6)
Mini-UHF	Straight Plug	TC-400-MUHF	3190-520	<1.25:1 (2.5)	Knurl	Solder	Crimp	N/G	1.1 (28)	0.50 (12.7)	0.020 (9.1)
N Female	Straight Jack	TC-400-NFC	3190-299	<1.25:1 (2.5)	NA	Solder	Clamp	N/S	1.6 (41)	0.75 (19.1)	0.119 (54.0)
N Male	Straight Plug	SC-400-NM	3190-1454	<1.25:1 (2.5)	Knurl	Solder	Crimp	N/G	1.5 (38)	0.75 (19.1)	0.090 (40.8)
	Straight Plug	TC-400-NM	3190-188	<1.25:1 (2.5)	Knurl	Solder	Crimp	N/G	1.5 (38)	0.75 (19.1)	0.090 (40.8)
	Straight Plug	TC-400-NMC	3190-277	<1.25:1 (2.5)	Knurl	Solder	Clamp	N/G	1.5 (38)	0.75 (19.1)	0.121 (54.9)
	Straight Plug	TC-400-NMH-D	3190-552	<1.25:1 (10)	Hex/Knurl	Solder	Crimp	A/G	1.5 (38)	0.89 (22.6)	0.113 (51.3)
	Right Angle	TC-400-NMH-RA	3190-422*	<1.35:1 (6)	Hex	Solder	Crimp	S/G	1.8 (46)	1.25 (31.8)	0.130 (59.0)
	Right Angle	TC-400-NMH-RA-D	3190-2293*	<1.35:1 (6)	Hex/Knurl	Solder	Crimp	A/G	1.8 (46)	1.25 (31.8)	0.130 (59.0)
SMA Male	Straight Plug	TC-400-SM	3190-439	<1.25:1 (8)	Hex	Solder	Crimp	N/G	1.2 (29)	0.50 (12.7)	0.032 (14.5)
TNC Male	Straight Plug	TC-400-TM	3190-260	<1.25:1 (2.5)	Knurl	Solder	Crimp	N/S	1.7 (43)	0.59 (15.0)	0.074 (33.6)
	Right Angle	TC-400-TM-RA	3190-442*	<1.35:1 (2.5)	Knurl	Solder	Crimp	N/G	1.7 (43)	0.59 (15.0)	0.085 (38.6)

\* Finish metals: N=Nickel, S=Silver, G=Gold, SS=Stainless Steel, A=Alballoy \*\*VSWR spec based on 3 foot cable with a connector pair \*Available in bulk pack

MICROWAVE

<b>Mechanical Specifications</b>			
Performance Property	Units	US	(metric)
Bend Radius: installation	in. (mm)	1.0	(25.4)
Bend Radius: repeated	in. (mm)	4.0	(101.6)
Bending Moment	ft-lb (N-m)	0.375	(0.51)
Weight	lb/ft (kg/m)	.088	(0.131)
Tensile Strength	lb (kg)	160	(72.6)
Flat Plate Crush	lb/in. (kg/mm)	20	(0.36)

<b>Environmental Specifications</b>		
Performance Property	°F	°C
Installation Temperature Range	-40/+185	-40/+85
Storage Temperature Range	-94/+185	-70/+85
Operating Temperature Range	-40/+185	-40/+85

<b>Electrical Specifications</b>			
Performance Property	Units	US	(metric)
Cutoff Frequency	GHz		16.2
Velocity of Propagation	%		85
Dielectric Constant	NA		1.38
Time Delay	nS/ft (nS/m)	1.20	(3.92)
Impedance	ohms		50
Capacitance	pF/ft (pF/m)	23.9	(78.40)
Inductance	uH/ft (uH/m)	0.060	(0.21)
Shielding Effectiveness	dB		>90
DC Resistance			
Inner Conductor	ohms/1000ft (/km)	1.07	(3.51)
Outer Conductor	ohms/1000ft (/km)	1.65	(5.4)
Voltage Withstand	Volts DC		2500
Jacket Spark	Volts RMS		8000
Peak Power	kW		16

**Attenuation vs. Frequency (typical)**



Frequency (MHz)	30	50	150	220	450	900	1500	1800	2000	2500	5800
Attenuation dB/100 ft	0.8	1.1	1.8	2.2	3.3	4.7	6.2	6.8	7.2	8.1	13.0
Attenuation dB/100 m	2.7	3.5	6.1	7.4	10.7	15.4	20.2	22.3	23.6	26.6	42.6
Avg. Power kW	2.77	2.14	1.22	1.00	0.69	0.48	0.36	0.33	0.31	0.28	0.17

Calculate Attenuation =  $(0.146748) \cdot \sqrt{\text{FMHz}} + (0.000312) \cdot \text{FMHz}$  (interactive calculator available at [http://www.timesmicrowave.com/cable\\_calculators](http://www.timesmicrowave.com/cable_calculators))  
 Attenuation: VSWR=1.0; Ambient = +25°C (77°F) Power: VSWR=1.0; Ambient = +40°C; Inner Conductor = 100°C (212°F);  
 Sea Level; dry air; atmospheric pressure; no solar loading



## Hardware Accessories

Type	Part Number	Stock Code	Description
Ground Kit	GK-S400TT	GK-S400TT	Standard Grounding Kit (each)
Hoisting Grip	HG-400T	HG-400T	Laced Type (each)



## Install Tools

Type	Part Number	Stock Code	Description
Crimp Tool	HX-4	3190-200	Crimp Handle
Crimp Dies	Y1719	3190-202	.429" Hex Dies
Crimp Tool	CT-400/300	3190-666	Crimp tool for LMR 400 connectors
Crimp Rings	CR-400	3190-830	Crimp rings for TC/EZ-400 connectors (package of 10)
Cutting Tool	CCT-01	3190-1544	Cable end flush cut tool
Replacement Blade	RB-01	3190-1609	Replacement blade for cutting tool