



SHV plug crimp right angle for RG174, RG188, RG316

## RF Connectors Technical Data Sheet

**PE45848**

### Configuration

- SHV Plug Connector
- MIL-STD-348B
- 50 Ohms
- Right Angle Body Geometry
- Connector Interface Types: RG147, RG188, RG316

### Features

- Max. Operating Frequency 300 MHz
- Tinned Copper Plated Brass Contact

### Applications

- General Purpose Test
- Custom Cable Assemblies

### Description

Pasternack's PE45848 SHV plug right angle connector with clamp/solder attachment for RG147, RG188 and RG316 is part of our full line of RF components available for same-day shipping. Our SHV plug connector operates up to a maximum frequency of 300 MHz. Its right angle body geometry allows for easier connections in tight spaces.

Our SHV plug right angle connector PE45848 datasheet specifications and drawing with dimensions are shown below in this PDF. Pasternack's broad catalog of RF, microwave and millimeter wave connectors allows designers to configure and customize their signal connections however they like. Whether the need is to provide an I/O for a board design, or simply create a custom cable assembly configuration, Pasternack has the right connector for the job. Pasternack can also expertly build your custom cable assemblies for you and ship same-day.

### Electrical Specifications

Description	Minimum	Typical	Maximum	Units
Frequency Range	DC		300	MHz
Operating Voltage (AC)			3,500	Vrms
Dielectric Withstanding Voltage (AC)			5,000	Vrms
Inner Conductor DC Resistance			2	mOhms
Outer Conductor DC Resistance			1.5	mOhms
Insulation Resistance	5,000			MOhms

### Mechanical Specifications

#### Size

Length	1.48 in [37.59 mm]
Width/Dia.	0.57 in [14.48 mm]
Height	0.88 in [22.35 mm]
Weight	0.062 lbs [28.12 g]

Click the following link (or enter part number in "SEARCH" on website) to obtain additional part information including price, inventory and certifications: [SHV plug crimp right angle for RG174, RG188, RG316 PE45848](#)



SHV plug crimp right angle for RG174, RG188, RG316

## RF Connectors Technical Data Sheet

**PE45848**

### Material Specifications

Description	Material	Plating
Contact	Brass	Tinned Copper
Contact Spring		Tinned Copper
Insulation	Teflon	
Body	Brass	Tinned Copper
Coupling Nut	Brass	Tinned Copper
Gasket	Silicon	
Crimp Sleeve	Brass	Tinned Copper
Washer	Brass	Tinned Copper BNC3100-6/W

### Environmental Specifications

#### Temperature

Operating Range  
Thermal Shock

-65 to +165 deg C  
MIL-STD-202, Method 107, Condition B

**Compliance Certifications** (see [product page](#) for current document)

### Plotted and Other Data

Notes:

SHV plug crimp right angle for RG174, RG188, RG316 from Pasternack Enterprises has same day shipment for domestic and International orders. Our RF, microwave and millimeter wave products maintain a 99.4% availability and are part of the broadest selection in the industry.

Click the following link (or enter part number in "SEARCH" on website) to obtain additional part information including price, inventory and certifications: [SHV plug crimp right angle for RG174, RG188, RG316 PE45848](#)

URL: <https://www.pasternack.com/shv-plug-rg147-rg188-rg316-connector-pe45848-p.aspx>

The information contained in this document is accurate to the best of our knowledge and representative of the part described herein. It may be necessary to make modifications to the part and/or the documentation of the part, in order to implement improvements. Pasternack reserves the right to make such changes as required. Unless otherwise stated, all specifications are nominal. Pasternack does not make any representation or warranty regarding the suitability of the part described herein for any particular purpose, and Pasternack does not assume any liability arising out of the use of any part or documentation.

# PE45848 CAD Drawing

SHV plug crimp right angle for RG174,RG188,RG316

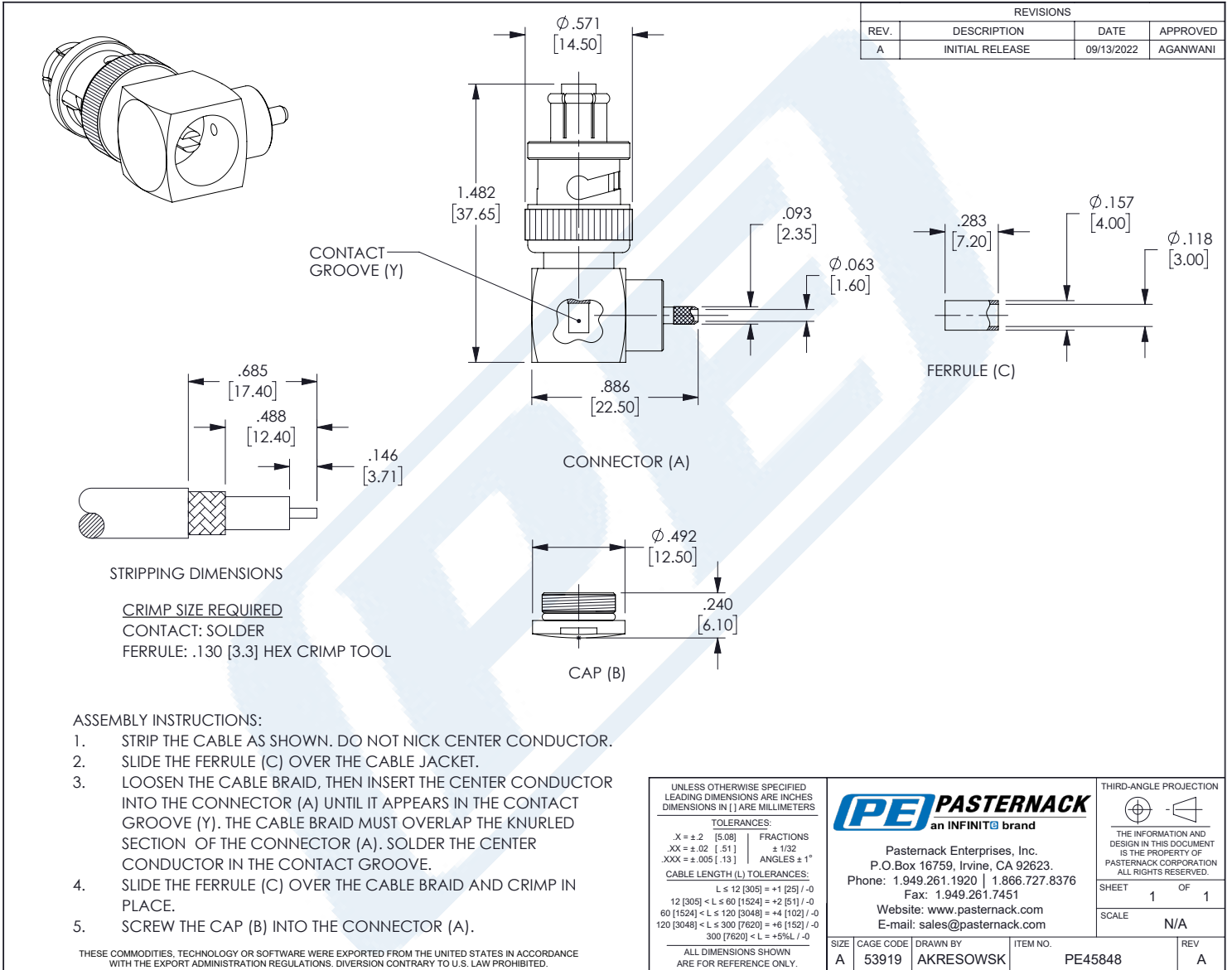

T-Rev.D



# SHV Jack Bulkhead Mount Connector Clamp/Solder Attachment for RG174, RG316, RG188, .480 inch D Hole

## RF Connectors Technical Data Sheet

PE45556

### Configuration

- SHV Jack Connector
- MIL-STD-348
- 50 Ohms
- Straight Body Geometry
- Connector Interface Types: RG174, RG316, RG188
- Bulkhead

### Features

- Silver Plated Brass Contact

### Applications

- General Purpose Test
- Rack and Panel Mount Applications
- Custom Cable Assemblies

### Description

Pasternack's PE45556 SHV jack bulkhead connector with clamp/solder attachment for RG174, RG316 and RG188 (.480 inch D hole) is part of our full line of RF components available for same-day shipping. This SHV bulkhead connector allows designers to create external connections on their product enclosures, and can be used in a variety of other rack mount and panel mount applications.

Our SHV jack bulkhead connector PE45556 datasheet specifications and drawing with dimensions are shown below in this PDF. Pasternack's broad catalog of RF, microwave and millimeter wave connectors allows designers to configure and customize their signal connections however they like. Whether the need is to provide an I/O for a board design, or simply create a custom cable assembly configuration, Pasternack has the right connector for the job. Pasternack can also expertly build your custom cable assemblies for you and ship same-day.

### Electrical Specifications

Description	Minimum	Typical	Maximum	Units
Dielectric Withstanding Voltage (AC)			5,000	Vrms

### Material Specifications

Description	Material	Plating
Contact	Brass	Silver
Insulation	PTFE	
Outer Conductor	Brass	Nickel
Body	Brass	Nickel
Gasket	Silicone Rubber	

Click the following link (or enter part number in "SEARCH" on website) to obtain additional part information including price, inventory and certifications: [SHV Jack Bulkhead Mount Connector Clamp/Solder Attachment for RG174, RG316, RG188, .480 inch D Hole PE45556](#)



SHV Jack Bulkhead Mount Connector Clamp/Solder  
Attachment for RG174, RG316, RG188, .480 inch D Hole

RF Connectors  
Technical Data Sheet

PE45556

**Environmental Specifications**

**Temperature**

Operating Range

-65 to +165 deg C

**Compliance Certifications** (see [product page](#) for current document)

**Plotted and Other Data**

Notes:

Click the following link (or enter part number in "SEARCH" on website) to obtain additional part information including price, inventory and certifications: [SHV Jack Bulkhead Mount Connector Clamp/Solder Attachment for RG174, RG316, RG188, .480 inch D Hole PE45556](#)



SHV Jack Bulkhead Mount Connector Clamp/Solder Attachment for RG174, RG316, RG188, .480 inch D Hole

RF Connectors  
Technical Data Sheet

PE45556

Assembly Instruction

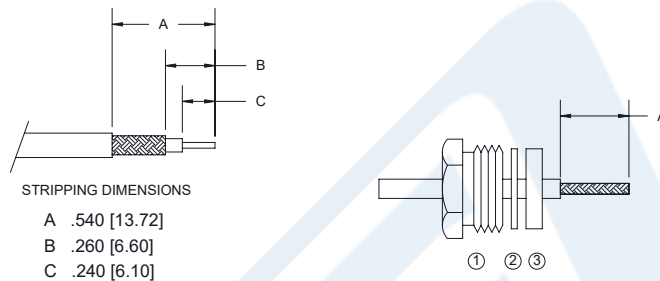

1. SLIDE CLAMP NUT ①, THINNER WASHER ② & GASKET ③ OVER CABLE. STRIP CABLE AS SHOWN. DO NOT NICK BRAID WHILE CUTTING JACKET. TAPER END OF BRAID TO PERMIT ASSEMBLY OF CLAMP.

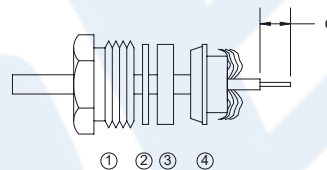

2. SLIDE BRAID CLAMP ④ OVER BRAID & SEAT AGAINST CABLE. FORM BRAID OVER CLAMP NUT. TRIM BRAID BACK TO SHOULDER. CUT DIELECTRIC & CENTER CONDUCTOR TO DIMENSION SHOWN. DO NOT NICK CENTER CONDUCTOR.

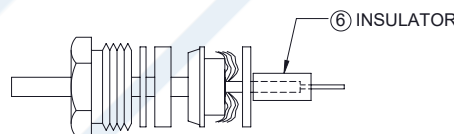

3. SLIDE THICKER WASHER ⑤ AND INSULATOR ⑥ AGAINST THE BRAID CLAMP. SOFT SOLDER CONTACT ⑦ TO CENTER CONDUCTOR. REMOVE EXCESS SOLDER. DO NOT OVER HEAT DIELECTRIC. INSERT CABLE ASSEMBLY INTO BODY ⑧ & TIGHTEN BY CLAMP NUT ONLY.

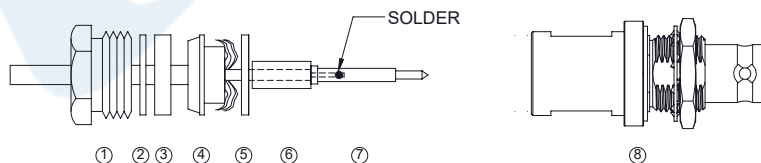

Click the following link (or enter part number in "SEARCH" on website) to obtain additional part information including price, inventory and certifications: [SHV Jack Bulkhead Mount Connector Clamp/Solder Attachment for RG174, RG316, RG188, .480 inch D Hole PE45556](#)



## SHV Jack Bulkhead Mount Connector Clamp/Solder Attachment for RG174, RG316, RG188, .480 inch D Hole

### RF Connectors Technical Data Sheet

PE45556

SHV Jack Bulkhead Mount Connector Clamp/Solder Attachment for RG174, RG316, RG188, .480 inch D Hole from Pasternack Enterprises has same day shipment for domestic and International orders. Our RF, microwave and millimeter wave products maintain a 99.4% availability and are part of the broadest selection in the industry.

Click the following link (or enter part number in "SEARCH" on website) to obtain additional part information including price, inventory and certifications: [SHV Jack Bulkhead Mount Connector Clamp/Solder Attachment for RG174, RG316, RG188, .480 inch D Hole PE45556](https://www.pasternack.com/shv-jack-rg174-rg316-rg188-connector-pe45556-p.aspx)

URL: <https://www.pasternack.com/shv-jack-rg174-rg316-rg188-connector-pe45556-p.aspx>

The information contained in this document is accurate to the best of our knowledge and representative of the part described herein. It may be necessary to make modifications to the part and/or the documentation of the part, in order to implement improvements. Pasternack reserves the right to make such changes as required. Unless otherwise stated, all specifications are nominal. Pasternack does not make any representation or warranty regarding the suitability of the part described herein for any particular purpose, and Pasternack does not assume any liability arising out of the use of any part or documentation.

# PE45556 CAD Drawing

SHV Jack Bulkhead Mount Connector Clamp/Solder Attachment  
for RG174, RG316, RG188, .480 inch D Hole

REV.	DESCRIPTION	DATE	APPROVED
A	INITIAL RELEASE	1/9/2020	S.ELLIS

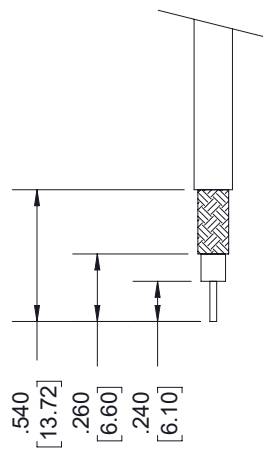
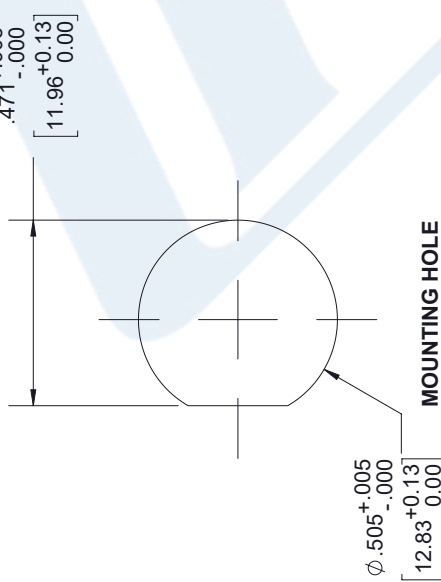
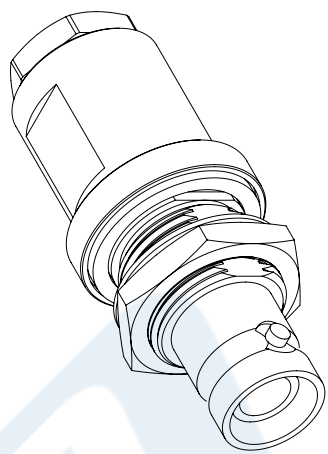
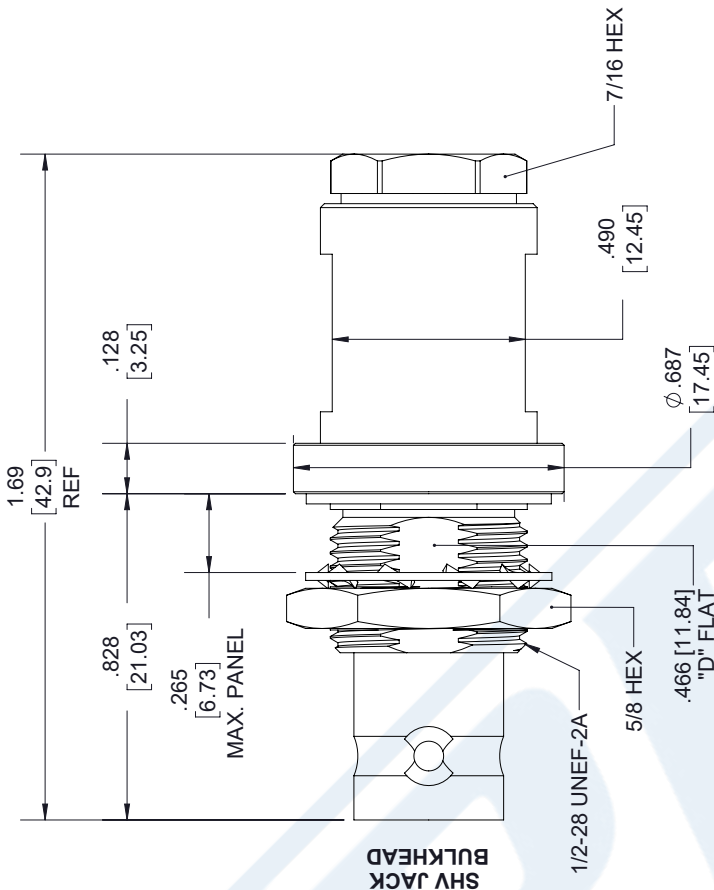

## STRIPPING DIMENSIONS

- NOTES:
- CABLE ATTACHMENT:
    - OUTER: CLAMP.
    - INNER: SOLDER.

UNLESS OTHERWISE SPECIFIED LEADING DIMENSIONS ARE INCHES DIMENSIONS IN [ ] ARE MILLIMETERS

TOLERANCES:

.X = ±.2	[5.08]	FRACTIONS
.XX = ±.02	[.51]	± 1/32
.XXX = ±.005	[.13]	ANGLES ± 1°

CABLE LENGTH (L) TOLERANCES:

L ≤ 12 [305]	± .1 [25]	/ -0
12 [305] < L ≤ 60 [1524]	± .2 [51]	/ -0
60 [1524] < L ≤ 120 [3048]	± .4 [102]	/ -0
120 [3048] < L ≤ 300 [7620]	± .6 [152]	/ -0
300 [7620] < L ≤ ∞	± .9% L / -0	

ALL DIMENSIONS SHOWN ARE FOR REFERENCE ONLY.

THIRD-ANGLE PROJECTION

THE INFORMATION AND DESIGN IN THIS DOCUMENT IS THE PROPERTY OF PASTERNAK CORPORATION. ALL RIGHTS RESERVED.

SHEET 1 OF 2

SCALE N/A

REV A

ITEM NO. PE45556

DRAWN BY K.DANG

CAGE CODE A 53919

SALES@pasternack.com

1.949.261.7451

www.pasternack.com

1.866.727.8376

P. O. Box 16759, Irvine, CA 92623.

Pasternack Enterprises, Inc.

an INFINITO brand

**PE PASTERNAK**

THESE COMMODITIES, TECHNOLOGY OR SOFTWARE WERE EXPORTED FROM THE UNITED STATES IN ACCORDANCE WITH THE EXPORT ADMINISTRATION REGULATIONS. DIVERSION CONTRARY TO U.S. LAW PROHIBITED.

# LMR<sup>®</sup>-100A Flexible Low Loss Communications Coax

## Ideal for...

- Drop-in Replacement for RG-316/RG-174 (uses standard connectors)
- Jumper Assemblies in Wireless Communications Systems
- Short Antenna Feeder runs
- Any application (e.g. WLL, GPS, LMR, WLAN, WiSP, WiMax, SCADA, Mobile Antennas) requiring an easily routed, low loss RF cable

• **LMR<sup>®</sup>-PVC** is designed for low loss general-purpose indoor/outdoor applications and is somewhat more flexible than the standard polyethylene jacketed LMR.

• **LMR<sup>®</sup>-PVC-W** is a white-jacketed version of LMR-PVC for marine and other indoor/outdoor applications where color compatibility is desired.

• **Flexibility** and bendability are hallmarks of the LMR-100A cable design. The flexible outer conductor enables the tightest bend radius available for any cable of similar size and performance.

• **Low Loss** is another hallmark feature of LMR-100A. Size for size LMR has the lowest loss of any flexible cable and comparable loss to semirigid hard-line cables.

• **RF Shielding** is 50 dB greater than typical single shielded coax (40 dB). The multi-ply bonded foil outer conductor is rated conservatively at > 90 dB (i.e. >180 dB between two adjacent cables).

• **Weatherability:** LMR-100A cables designed for outdoor exposure incorporate the best materials for UV resistance and have life expectancy in excess of 20 years.

• **Connectors:** A wide variety of connectors are available for LMR-100A cable, including all common interface types, reverse polarity, and a choice of solder or non-solder center pins. Most LMR connectors employ crimp outer attachment using standard hex crimp sizes.

• **Cable Assemblies:** All LMR-100A cable types are available as pre-terminated cable assemblies. Refer to the section on FlexTech for further details.

Part Description					Stock
Part Number	Application	Jacket	Color	Code	
LMR-100A-FR	Indoor/Outdoor Riser CMR	FRPE	Black	54037	
LMR-100A-PVC	Indoor/Outdoor	PVC	Black	54119	
LMR-100A-PVC-W	Indoor/Outdoor	PVC	White	54200	

PVC = Poly Vinyl Chloride; MTO = Made to Order

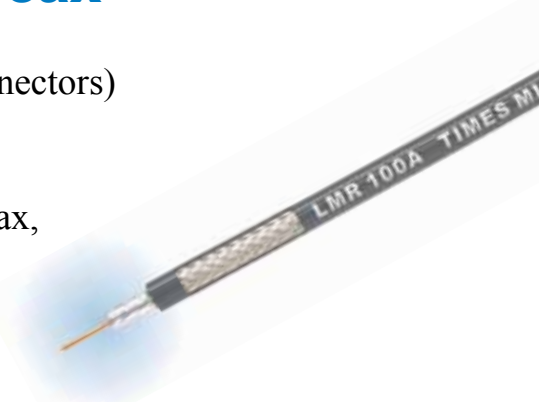

Construction Specifications			
Description	Material	In.	(mm)
Inner Conductor	Solid BCCS	0.018	(0.46)
Dielectric	Solid PE	0.060	(1.52)
Outer Conductor	Aluminum Tape	0.065	(1.65)
Overall Braid	Tinned Copper	0.083	(2.11)
Jacket	(see table above)	0.110	(2.79)

Mechanical Specifications			
Performance Property	Units	US	(metric)
Bend Radius: installation	in. (mm)	0.25	(6.4)
Bend Radius: repeated	in. (mm)	1	(25.4)
Bending Moment	ft-lb (N-m)	0.1	(0.014)
Weight	lb/ft (kg/m)	0.0092	(.014)
Tensile Strength	lb (kg)	15	(6.8)
Flat Plate Crush	lb/in. (kg/mm)	10	(0.18)

Environmental Specifications		
Performance Property	°F	°C
Installation Temperature Range	-40/+185	-40/+85
Storage Temperature Range	-94/+185	-70/+85
Operating Temperature Range	-40/+185	-40/+85

Electrical Specifications			
Performance Property	Units	US	(metric)
Velocity of Propagation	%	66	
Dielectric Constant	NA	2.30	
Time Delay	nS/ft (nS/m)	1.54	(5.05)
Impedance	ohms	50	
Capacitance	pF/ft (pF/m)	30.8	(101.1)
Inductance	uH/ft (uH/m)	0.077	(0.25)
Shielding Effectiveness	dB	>90	
DC Resistance			
Inner Conductor	ohms/1000ft (/km)	81.0	(266)
Outer Conductor	ohms/1000ft (/km)	9.5	(31.2)
Voltage Withstand	Volts DC	500	
Jacket Spark	Volts RMS	2000	
Peak Power	kW	0.6	

**Attenuation vs. Frequency (typical)**



Frequency (MHz)	30	50	150	220	450	900	1500	1800	2000	2500	5800
<b>Attenuation dB/100 ft</b>	3.9	5.1	8.9	10.9	15.8	22.8	30.1	33.2	35.2	39.8	64.1
<b>Attenuation dB/100 m</b>	12.9	16.7	29.4	35.8	51.9	74.9	98.7	109.0	115.5	130.6	210.3
<b>Avg. Power kW</b>	0.230	0.180	0.100	0.083	0.057	0.039	0.029	0.027	0.025	0.022	0.013

**Calculate Attenuation** =  $(0.709140) \cdot \sqrt{\text{FMHz}} + (0.001740) \cdot \text{FMHz}$  (interactive calculator available at <http://www.timesmicrowave/telecom>)  
**Attenuation:** VSWR=1.0 ; Ambient = +25°C (77°F) **Power:** VSWR=1.0; Ambient = +40°C; Inner Conductor = 100°C (212°F);  
 Sea Level; dry air; atmospheric pressure; no solar loading



**Connectors**

Interface	Description	Part Number	Stock Code	VSWR ** Freq. (GHz)	Coupling Nut	Inner Contact Attach	Outer Contact Attach	Finish* Body /Pin	Length in (mm)	Width in (mm)	Weight lb (g)
SMA male	Straight Plug	TC-100-SM	3190-1551	<1.25:1 (<3)	Hex	Solder	Crimp	SS/G	1.0 (25.4)	0.32 (8.1)	0.015 (6.8)
TNC male	Straight Plug	TC-100-TM	3190-1552	<1.25:1 (<3)	Knurl	Solder	Crimp	S/G	1.4 (35.6)	0.59 (15.0)	0.045 (20.4)

\* Finish metals: N=Nickel, S=Silver, G=Gold, SS=Stainless Steel, A=Alballoy \*\*VSWR spec based on 3 foot cable with a connector pair



**Install Tools**

Type	Part Number	Stock Code	Description
Crimp Tool	CT-240/200/195/100	3190-667	Crimp tool for LMR-100, 195, 200 and 240 connectors
Cutting Tool	CCT-01	3190-1544	Cable end flush cut tool
Replacement Blade	RB-01	3190-1609	Replacement blade for cutting tool

