

NOTICE OF PROPRIETARY RIGHTS THIS DOCUMENT CONTAINS CONFIDENTIAL TECHNICAL DATA, INCLUDING TRADE SECRETS, PROPRIETARY TO TIMES MICROWAVE SYSTEMS. DISCLOSURE OF THIS DATA IS EXPRESSLY CONDITIONED UPON YOUR ASSENT THAT ITS USE IS LIMITED TO USE WITHIN YOUR COMPANY ONLY. ANY OTHER USE IS STRICTLY PROHIBITED WITHOUT THE PRIOR WRITTEN CONSENT OF TIMES MICROWAVE SYSTEMS.

SYM	REVISION DESCRIPTION	DFTM	DATE	APPD	DATE
A	RELEASED FOR PRODUCTION	K.A.M.	6/3/11	J.D.B.	6/3/11
B	CHANGED PER CDC #34607/36250	D.J.H.	9/24/12	J.D.B.	9/25/12

RECOMMENDED CABLE STRIPPING DIM'S.

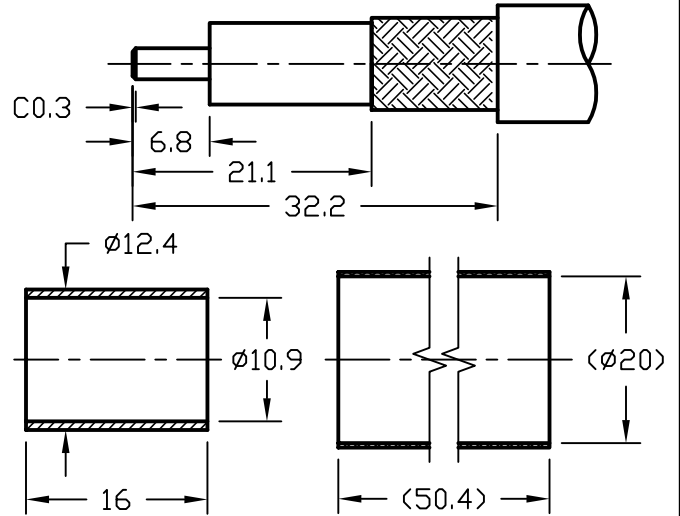
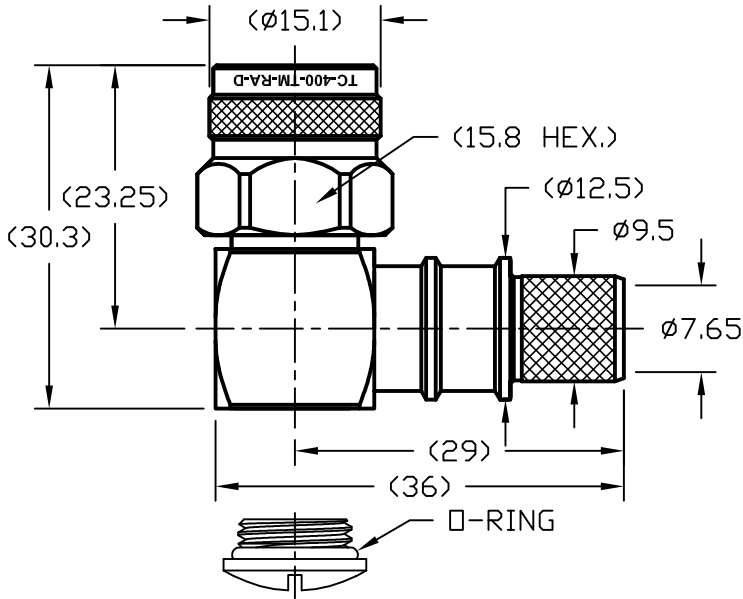

NOTES:

- CONTACT PIN IS SOLDERED.
- FERRULE IS CRIMPED TO .429" HEX.

ALL PARTS SATISFIED ROHS REQUIREMENTS

MATERIALS AND PLATING		UNIT: MICRO-INCHES
BODY/SHELL	BRASS C3604	ALBALOY 80 MIN/COPPER
CONTACT PIN	BRASS C3604	GOLD 50 MIN/NICKEL/COPPER
INSULATOR	TEFLON MIL-P-19468	N/A
GASKET	SILICONE	RED
FERRULE	BRASS	ALBALOY 80 MIN/COPPER
SHRINK TUBING	PO	BLACK

ELECTRICAL CHARACTERISTICS	
Impedance	50 Ω
Frequency range	0~11GHz
Voltage rating	500V(rms)
Dielectric withstanding voltage	1000V
Contact resistance	Center contact ≤ 3 mΩ
	Outer contact ≤ 2 mΩ
Insulation resistance	≥ 5000MΩ
Insertion loss	According to the cable
RF-leakage	N/A
VSWR	≤ 1.35 MAX@0-6GHz

MECHANICAL CHARACTERISTICS	
Force to engage and disengage	N/A
Center contact retention force	6 lbs Min
Coupling torque	15 in-lbs Min
Coupling nut retention force	60 lbs Min
Durability	≥ 500 cycles

ENVIRONMENTAL CHARACTERISTICS	
Temperature range	-55°C - +125°C
Thermal Shock	MIL-STD-202, Method 107, Cond B
Vibration	MIL-STD-202, Method 204, Cond B
Shock	MIL-STD-202, Method 213, Cond I
Climatic Class	IEC 60068 55/155/56

MATERIAL: UNLESS OTHERWISE SPECIFIED	DFTM: K. A. M.	TIMES MICROWAVE SYSTEMS					
	DATE: 6/3/11						
USED ON: 0-4	ALL DIMENSIONS ARE IN mm MACHINED SURFACES FINISH 1.6 RMS MAX. REMOVE ALL BURRS 0.15X45° MAX. BREAK MACHINE CORNERS 0.15X45°D MAX. FILLET R. TOLERANCES ON DECIMALS .X ± 0.3 .XX ± 0.2 ANGLES ± 1° FRACTIONS ± N/A	TC-400-TM-RA-D 90° TNC MALE FOR LMR400 CABLE					
	DATE: 6/3/11						
SCALE: N/A	DWG. SIZE: A	DO NOT SCALE DRAWING	CODE IDENT: 68999	DATE: 6/3/11	SHEET: 1 of 1	SD3190-2671	REV: B

RP-N Plug Connector Crimp/Solder Attachment for PE-C400, PE-B400, PE-B405, LMR-400, LMR-400-DB, LMR-400-UF



PE44470

Configuration

- N Plug Reverse Polarity Connector
- 50 Ohms
- Straight Body Geometry
- Connector Interface Types: PE-C400, PE-B400, PE-B405, LMR-400, LMR-400-DB, LMR-400-UF

Features

- Max. Operating Frequency 11 GHz
- Gold Plated Brass Contact
- Reverse Polarity

Applications

- General Purpose Test
- Custom Cable Assemblies

Description

Pasternack's PE44470 RP type N plug connector with crimp/solder attachment for PE-C400, PE-B400, PE-B405, LMR-400, LMR-400-DB, LMR-400-UF is part of our full line of RF components available for same-day shipping. The plug reverse polarity configuration uses a plug connector body with a female inner contact receptacle. Our type N plug connector operates up to a maximum frequency of 11 GHz.

Our reverse polarity type N plug connector PE44470 datasheet specifications and drawing with dimensions are shown below in this PDF. Pasternack's broad catalog of RF, microwave and millimeter wave connectors allows designers to configure and customize their signal connections however they like. Whether the need is to provide an I/O for a board design, or simply create a custom cable assembly configuration, Pasternack has the right connector for the job. Pasternack can also expertly build your custom cable assemblies for you and ship same-day.

Electrical Specifications

Description	Minimum	Typical	Maximum	Units
Frequency Range	DC		11	GHz
Insertion Loss			0.2	dB
Operating Voltage (DC)			1,500	Vdc
Dielectric Withstanding Voltage (AC)			2,500	Vrms
Impedance		50		Ohms

Mechanical Specifications

Size

Length	1.465 in [37.21 mm]
Width	0.83 in [21.08 mm]
Height	0 in [0 mm]
Weight	0.078 lbs [35.38 g]

Material Specifications

Description	Material	Plating
Contact	Brass	Gold
Insulation	PTFE	
Body	Brass	Nickel
Coupling Nut	Brass	Nickel

RP-N Plug Connector Crimp/Solder Attachment for PE-C400, PE-B400, PE-B405, LMR-400, LMR-400-DB, LMR-400-UF



PE44470

Environmental Specifications

Temperature

Operating Range

-55 to +85 deg C

Vibration

MIL-Std. 202 Method 204 (Test Condition B)

Altitude

MIL-Std. 202 Method 105 (Test Condition C)

Temperature Cycle

MIL-Std. 202 Method 102 (Test Condition C) All N-type Connectors are Weatherproof

Environmental Specification Notes:

Moisture Resistance: MIL-Std. 202 Method 106 (Test Condition B) ; Corrosion: MIL-Std. 202 Method 101 (Test Condition C)

Compliance Certifications (see [product page](#) for current document)

Plotted and Other Data

Notes:

RP-N Plug Connector Crimp/Solder Attachment for PE-C400, PE-B400, PE-B405, LMR-400, LMR-400-DB, LMR-400-UF from Pasternack Enterprises has same day shipment for domestic and International orders. Our RF, microwave and millimeter wave products maintain a 99.4% availability and are part of the broadest selection in the industry.

Click the following link (or enter part number in "SEARCH" on website) to obtain additional part information including price, inventory and certifications: [RP-N Plug Connector Crimp/Solder Attachment for PE-C400, PE-B400, PE-B405, LMR-400, LMR-400-DB, LMR-400-UF PE44470](#)

URL: <https://www.pasternack.com/n-male-reverse-polarity-pe-b400-pe-b405-pe-c400-connector-pe44470-p.aspx>

The information contained within this document is accurate to the best of our knowledge and representative of the part described herein. It may be necessary to make modifications to the part and/or the documentation of the part in order to implement improvements. Pasternack Enterprises reserves the right to make such changes as required. Unless otherwise stated, all specifications are nominal. Pasternack Enterprises does not make any representation or warranty regarding the suitability of the part described herein for any particular purpose, and Pasternack Enterprises does not assume liability arising out of the use of any part or document.

PE44470 CAD Drawing

RP-N Plug Connector Crimp/Solder Attachment for PE-C400, PE-B400, PE-B405, LMR-400, LMR-400-DB, LMR-400-UF

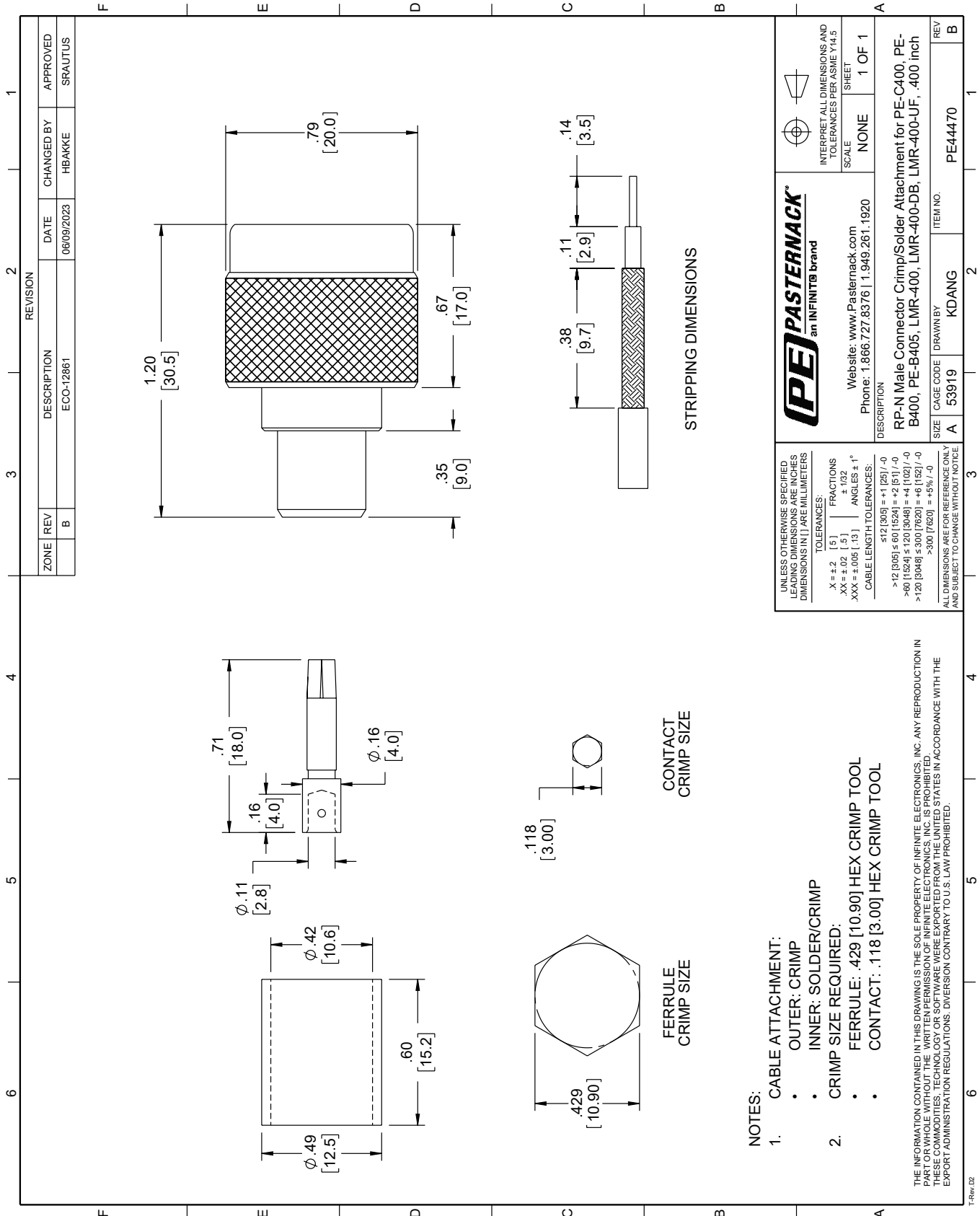

ZONE	REV	DESCRIPTION	DATE	CHANGED BY	APPROVED
	B	ECO-12861	06/09/2023	HBAKKE	SRAUTUS

PE PASTERNAK
an INFINITE brand

Website: www.Pasternack.com
Phone: 1.866.727.8376 | 1.949.261.1920

UNLESS OTHERWISE SPECIFIED LEADING DIMENSIONS ARE INCHES DIMENSIONS IN [] ARE MILLIMETERS

TOLERANCES:
 X = ±.2 (5) FRACTIONS ± 1/32
 XX = ±.02 (.5) ANGLES ± 1°
 XXX = ±.005 (.13) CABLE LENGTH TOLERANCES:
 <12 [305] ±.001 [620] ±.001 [25] / -0
 <60 [1524] ±.001 [620] ±.001 [25] / -0
 <120 [3048] ±.001 [620] ±.001 [25] / -0
 >120 [3048] ±.001 [620] ±.001 [25] / -0
 >300 [7620] ±.001 [25] / -0

ALL DIMENSIONS ARE FOR REFERENCE ONLY AND SUBJECT TO CHANGE WITHOUT NOTICE

INTERPRET ALL DIMENSIONS AND TOLERANCES PER ASME Y14.5

SCALE: NONE SHEET: 1 OF 1

DESCRIPTION: RP-N Male Connector Crimp/Solder Attachment for PE-C400, PE-B400, PE-B405, LMR-400, LMR-400-DB, LMR-400-UF, .400 inch

SIZE: A CAGE CODE: 53919 DRAWN BY: KDANG ITEM NO.: PE44470 REV: B

- NOTES:
- CABLE ATTACHMENT:
 - OUTER: CRIMP
 - INNER: SOLDER/CRIMP
 - CRIMP SIZE REQUIRED:
 - FERRULE: .429 [10.90] HEX CRIMP TOOL
 - CONTACT: .118 [3.00] HEX CRIMP TOOL

THE INFORMATION CONTAINED IN THIS DRAWING IS THE SOLE PROPERTY OF INFINITE ELECTRONICS, INC. ANY REPRODUCTION IN PART OR WHOLE WITHOUT THE WRITTEN PERMISSION OF INFINITE ELECTRONICS, INC. IS PROHIBITED. THESE COMMODITIES, TECHNOLOGY OR SOFTWARE WERE EXPORTED FROM THE UNITED STATES IN ACCORDANCE WITH THE EXPORT ADMINISTRATION REGULATIONS. DIVERSION CONTRARY TO U.S. LAW PROHIBITED.

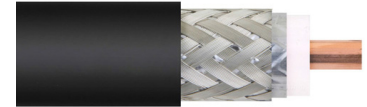

Low Loss Flexible LMR-400 Outdoor Rated Coax Cable Double Shielded with Black PE Jacket

RF Cables Technical Data Sheet

Times Microwave Systems Coax Cable Specification Configuration

- Low Loss, Outdoor Flexible Cable
- 2 Shield(s)

Features

- Flexible Low Loss Communications Coax
- Replacement for Air Dielectric type RG8 cable
- Double Shields provides RF Shielding in excess of 90 db
- Low Loss size for size compared to standard flexible cable

Description

Flexible Low Loss Communications Coax Replacement for Air Dielectric type RG8 cable Double Shields provides RF Shielding in excess of 90 db Low Loss size for size compared to standard flexible cable

Electrical Specifications

Description	Minimum	Typical	Maximum	Units
Frequency Range	DC		6	GHz
Impedance		50		Ohms
Velocity of Propagation		85		%
Time Delay		1.2 [3.94]		ns/ft [ns/m]
Shielding Effectiveness	90			dB
Dielectric Withstanding Voltage (DC)			2,500	Vdc
Jacket Spark			8,000	Vrms
Inner Conductor DC Resistance			1.39	Ohms/1000ft
Outer Conductor DC Resistance			1.65	Ohms/1000ft
Nominal Capacitance		23.9 [78.41]		pF/ft [pF/m]
Nominal Inductance		0.06 [0.2]		uH/ft [uH/m]
Input Power (Peak)			16	kWatts

Click the following link (or enter part number in "SEARCH" on website) to obtain additional part information including price, inventory and certifications: [Low Loss Flexible LMR-400 Outdoor Rated Coax Cable Double Shielded with Black PE Jacket LMR-400](#)

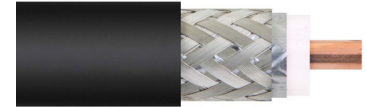

Low Loss Flexible LMR-400 Outdoor Rated Coax Cable Double Shielded with Black PE Jacket

RF Cables Technical Data Sheet

Performance by Frequency Band

Description	F1	F2	F3	F4	F5	Units
Frequency	50	150	220	450	900	MHz
Attenuation, Typ	0.9	1.5	1.9	2.7	3.9	dB/100ft
	2.95	4.92	6.23	8.86	12.8	dB/100m
Input Power (CW), Max	2,570	1,470	1,200	830	580	Watts

Description	F6	F7	F8	F9	F10	Units
Frequency	1.5	1.8	2	2.5	5.8	GHz
Attenuation, Typ	5.1	5.7	6	6.8	10.8	dB/100ft
	16.73	18.7	19.69	22.31	35.43	dB/100m
Input Power (CW), Max	440	400	370	330	210	Watts

Mechanical Specifications

Diameter	0.405 in [10.29 mm]
Weight	0.067 lbs/ft [0.1 kg/m]
Min. Bend Radius (Installation)	1 in [25.4 mm]
Min. Bend Radius (Repeated)	4 in [101.6 mm]
Bending Moment	0.5 lbs-ft [0.68 N-m]
Tensile Strength	160 lbs [72.57 kg]
Flat Plate Crush	40 lbs/in [0.71 kg/mm]

Construction Specifications

Description	Material and Plating	Diameter
Inner Conductor	Copper Clad Aluminum, 1 Strand	0.108 in [2.74 mm]
Conductor Type	Solid	
Dielectric	PE (F)	0.285 in [7.24 mm]
First Shield	Aluminum Tape	0.29 in [7.37 mm]
Second Shield	Tinned Copper Braid	0.32 in [8.13 mm]

Click the following link (or enter part number in "SEARCH" on website) to obtain additional part information including price, inventory and certifications: [Low Loss Flexible LMR-400 Outdoor Rated Coax Cable Double Shielded with Black PE Jacket LMR-400](#)



Low Loss Flexible LMR-400 Outdoor Rated Coax Cable Double Shielded with Black PE Jacket

RF Cables Technical Data Sheet



LMR-400

Jacket	PE, Black	0.405 in [10.29 mm]
--------	-----------	---------------------

Environmental Specifications

Temperature

Operating Range

-40 to 85 deg C

Storage Range

-70 to 85 deg C

Compliance Certifications (see [product page](#) for current document)

Plotted and Other Data

Notes:

Low Loss Flexible LMR-400 Outdoor Rated Coax Cable Double Shielded with Black PE Jacket from Pasternack Enterprises has same day shipment for domestic and International orders. Our RF, microwave and millimeter wave products maintain a 99.4% availability and are part of the broadest selection in the industry.

Click the following link (or enter part number in "SEARCH" on website) to obtain additional part information including price, inventory and certifications: [Low Loss Flexible LMR-400 Outdoor Rated Coax Cable Double Shielded with Black PE Jacket LMR-400](#)

URL: <https://www.pasternack.com/50-ohm-low-loss-flexible-lmr400-pe-jacket-double-shielded-black-lmr-400-p.aspx>

The information contained in this document is accurate to the best of our knowledge and representative of the part described herein. It may be necessary to make modifications to the part and/or the documentation of the part, in order to implement improvements. Pasternack reserves the right to make such changes as required. Unless otherwise stated, all specifications are nominal. Pasternack does not make any representation or warranty regarding the suitability of the part described herein for any particular purpose, and Pasternack does not assume any liability arising out of the use of any part or documentation.

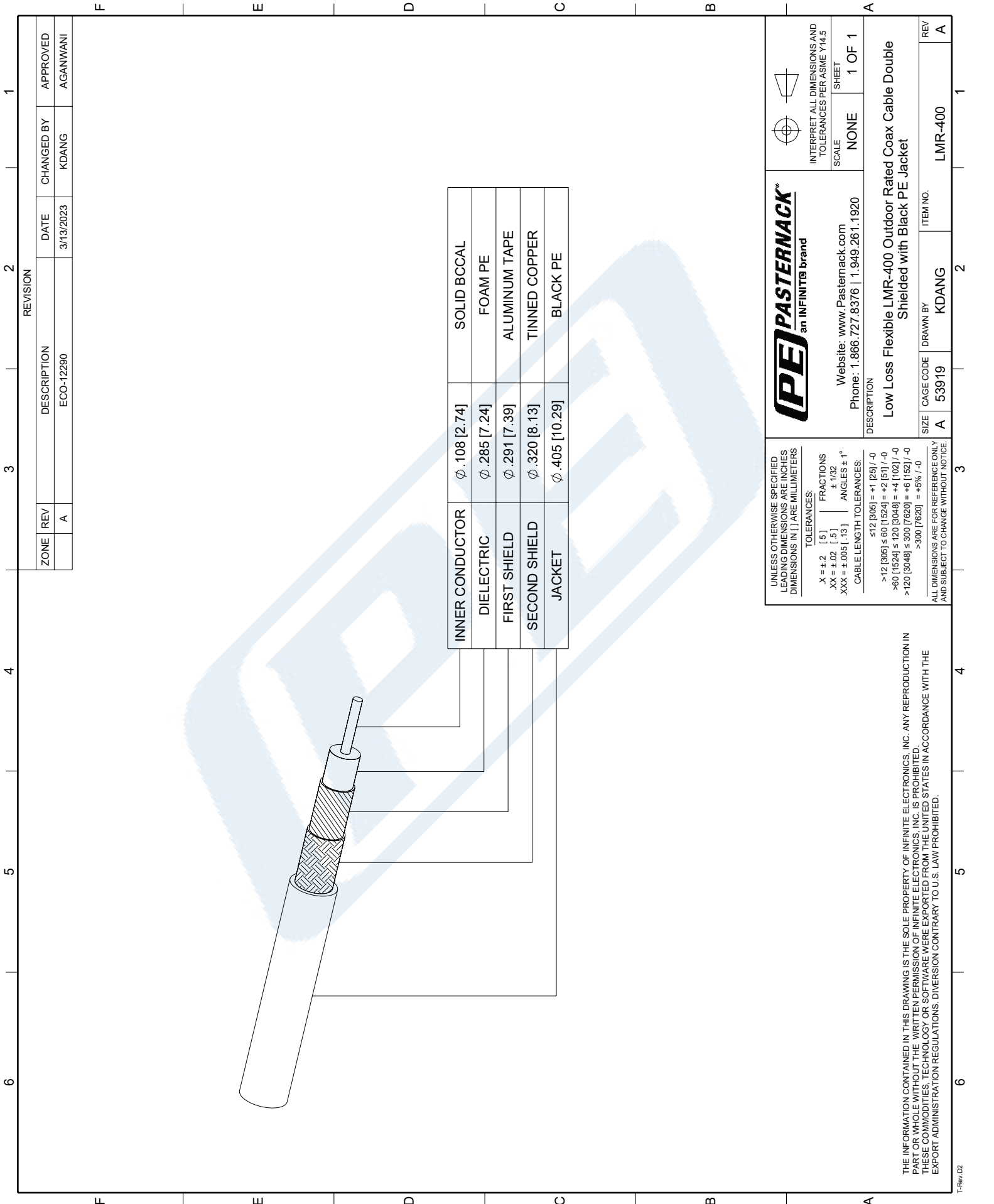

INNER CONDUCTOR	Ø .108 [2.74]	SOLID BCCAL
DIELECTRIC	Ø .285 [7.24]	FOAM PE
FIRST SHIELD	Ø .291 [7.39]	ALUMINUM TAPE
SECOND SHIELD	Ø .320 [8.13]	TINNED COPPER
JACKET	Ø .405 [10.29]	BLACK PE

ZONE	REV	DESCRIPTION	DATE	CHANGED BY	APPROVED
	A	ECO-12290	3/13/2023	KDANG	AGANWANI

(PE) PASTERNAK[®]
an INFINITIB brand

Website: www.Pasternack.com
Phone: 1.866.727.8376 | 1.949.261.1920

INTERPRET ALL DIMENSIONS AND TOLERANCES PER ASME Y14.5

SCALE: NONE SHEET: 1 OF 1

DESCRIPTION:
Low Loss Flexible LMR-400 Outdoor Rated Coax Cable Double Shielded with Black PE Jacket

SIZE	CAGE CODE	DRAWN BY	ITEM NO.
A	53919	KDANG	LMR-400

UNLESS OTHERWISE SPECIFIED LEADING DIMENSIONS ARE INCHES DIMENSIONS IN [] ARE MILLIMETERS

TOLERANCES:
 X = ±.2 [5] FRACTIONS ± 1/32
 .XX = ±.02 [.5] ANGLES ± 1°
 .XXX = ±.005 [.13]

CABLE LENGTH TOLERANCES:
 ≤12 [305] = +1 [25] / -0
 >12 [305] ≤ 60 [1524] = +2 [51] / -0
 >60 [1524] ≤ 120 [3048] = +4 [102] / -0
 >120 [3048] ≤ 300 [7620] = +6 [152] / -0
 >300 [7620] = +6% / -0

ALL DIMENSIONS ARE FOR REFERENCE ONLY AND SUBJECT TO CHANGE WITHOUT NOTICE.

THE INFORMATION CONTAINED IN THIS DRAWING IS THE SOLE PROPERTY OF INFINITE ELECTRONICS, INC. ANY REPRODUCTION IN PART OR WHOLE WITHOUT THE WRITTEN PERMISSION OF INFINITE ELECTRONICS, INC. IS PROHIBITED. THESE COMMODITIES, TECHNOLOGY OR SOFTWARE WERE EXPORTED FROM THE UNITED STATES IN ACCORDANCE WITH THE EXPORT ADMINISTRATION REGULATIONS. DIVERSION CONTRARY TO U.S. LAW PROHIBITED.